

FORCE USA

ORIGINAL LEG PRESS HACK SQUAT

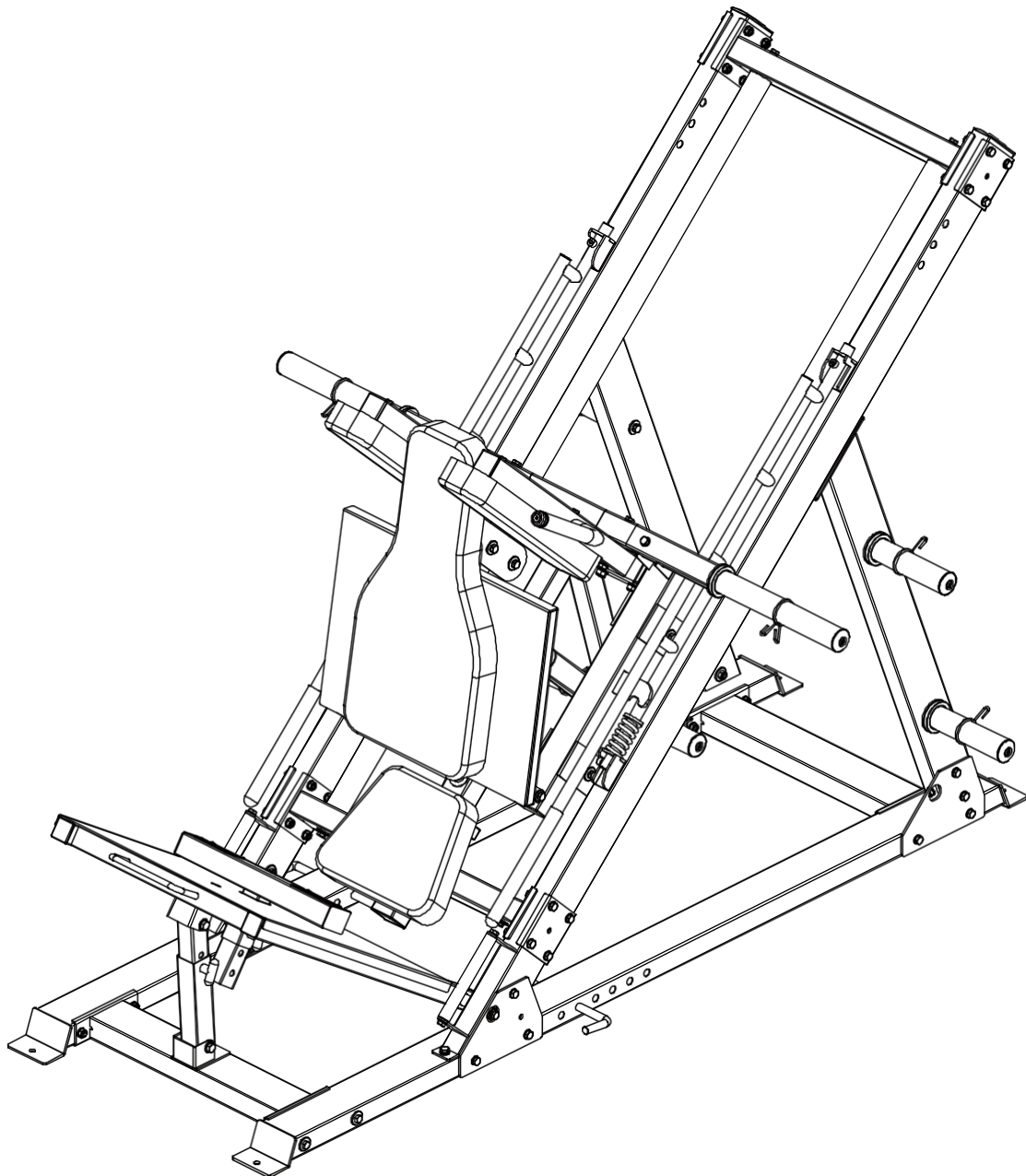

OWNER'S MANUAL | F-MLPHS-V2

CONTENTS

List of parts	2-5
Installation step 1	6-7
Installation step 2	8-10
Assembly step 3	11-14
Installation step 4	15-18
Assembly step 5	19-22
Installation step 6	23-24
Installation step 7	25-27

LIST OF WORKS

KEY NUMBER	PART DESCRIPTION	QUALITY
1	Grounding pipe on the right	1
2	Ground Link Pipe	1
3	Front grounding tube	1
4	Large flat washer $\phi 30 \times \phi 10 \times 3$	48
5	Flat washer $\phi 10$	86
6	Locking nut M10	46
7	Hexagon bolt M10*120	12
8	Earth pipe - left	1
9	Fixing plate	4
10	Back support tube	1
11	Back support tube - left	1
12	Hexagon bolt M10*70	30
13	Hexagon bolt M10*115	2
14	Inclined pipe Mounting part	1
15	Flexible washer $\phi 10$	38
16	Hexagon bolt M10*20	34
17	Inclined pipe - right part of the assembly	1
18	Guide rod down Fixed tube Mounting part	1
19	Fixed guide part of the pipe installation	1
20	Mounting part of the sliding bar	2
21	Mounting part of the slider frame	1
22	Mounting part of the end rail	1
23	100*130*4 Connecting plate	4
24	Hexagon bolt M10*30	8
25	External setting tube assembly of the foot press	1
26	Footstool	1

LIST OF WORKS

KEY NUMBER	PART DESCRIPTION	QUALITY
27	Leg press adjustment assembly	1
28	Axle with internal thread $\phi 15,9 \times 135$	2
29	Flat washer $\phi 12$	14
30	Locking nut M12	6
31	Hexagon bolt M12*80	2
32	T-shaped pin	1
33	Part of the end frame assembly	2
34	Spring	2
35	Hexagon head screws M10*20	4
36	Mounting plate upside down Part	1
37	Mounting part of the Regulatory Fixing Pipe	1
38	Shoulder pads Frame - right mounting part	1
39	Dumbbell holder frame	1
40	Hexagon bolt M10*65	2
41	Hexagon bolt M10*115	2
42	Shoulder pads Frame - left mounting part	1
43	Hexagon bolt M12*75	4
44	Hexagon bolt M12*65	2
45	Part of the lifting frame assembly	1
46	Inner bar for dumbbells	1
47	Holder for dumbbells	2
48	Hexagon head screws M8*20	2
49	Holder for dumbbells	4
50	Spring collar	8
51	Rear pad	1
52	Shoulder pad	2

LIST OF WORKS

KEY NUMBER	PART DESCRIPTION	QUALITY
53	Flat washer $\phi 8$	8
54	Hexagon bolt M8*70	4
55	Seat pad	1
56	Hexagon bolt M8*45	4
57	Peg Band	2
58	Legs Brick frame	1
59	T-shaped pin	1
60	Large flat washer $\phi 25 \phi * 10 * 2$	8
61	Axle with internal thread $\phi 15,9 * 120$	2
62	Handle tube	2
63	Pipe plug 50*100*2	2
64	Double layer spring nut $\phi 23-M10$	2
65	Pipe plug $\phi 60 * 60 * 2$	1
66	Pipe plug $\phi 25 * 25 * 1,5$	4
67	Roller $\phi 59$	8
68	Inner axis threaded $\phi 17 * 81-M10$	8
69	Bearing 6003	16
70	Plug 50*70*2	4
71	Pull the pin	1
72	Stainless steel bar $\phi 50 * 0,8$	1
73	Pipe cover $\phi 30 * \phi 25 * 50$	1
74	Pipe plug $\phi 50 * 50 * 2$	3
75	Tube plug $\phi 45 * 45 * 2$	5
76	Handle cover $\phi 24,5 * 280$	1
77	Round plug $\phi 25 * 2$	1
78	Pipe plug $\phi 25 * 25 * 1,5$	2

LIST OF WORKS

KEY NUMBER	DESCRIPTION OF THE WORK	QUALITY
79	φ50*345 Stainless steel pipe φ49.5*6	2
80	φ48*344 Inner tube φ48*1,5	2
81	End cap φ50*φ44,8*φ25,5	2
82	Middle cap φ70*φ44,8*φ25,5*30	2
83	Hexagon head screws M8*20	2
84	Handle cover φ32*310	2
85	Fixing ring φ31,5*φ25,5	2
86	Screw with countersunk head M10*25	2
87	Rear washer fixing plate	1
88	Screw with countersunk head M8*20	4
89	Anti-slip film	2
90	Flat blind rivet with round head 4*10	6
91	Double layer spring nut φ29-M10	2

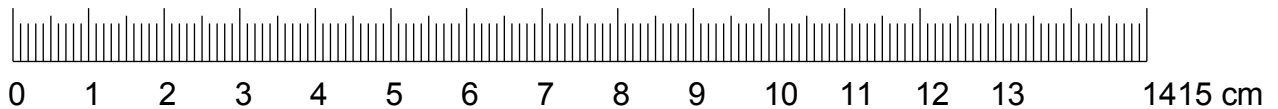

Screw length gauge

ASSEMBLY STEP

1

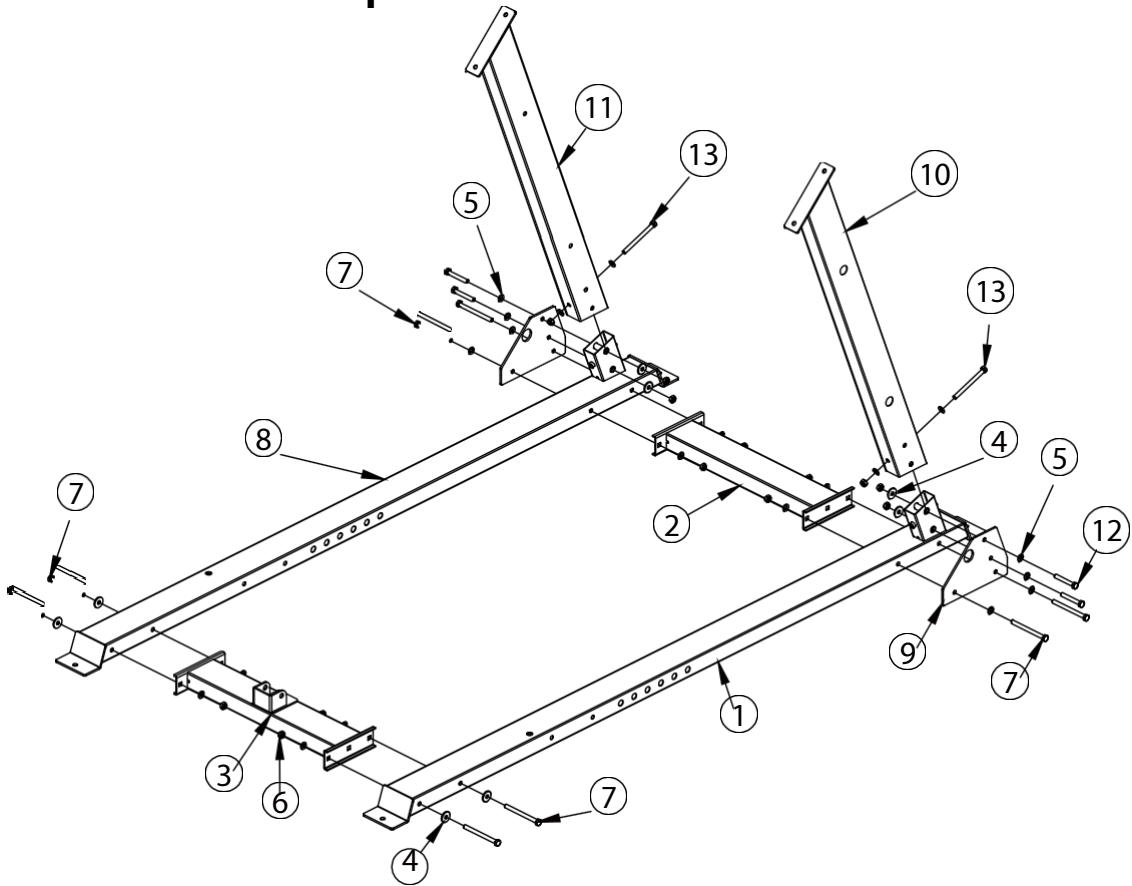

KEY NUMBER	DESCRIPTION OF THE WORK	QUALITY
1	Grounding pipe on the right	1
2	Ground Link Pipe	1
3	Front grounding tube	1
4	Large flat washer $\phi 30 \times \phi 10 \times 3$	8
5	Flat washer $\phi 10$	20
6	Locking nut M10	14
7	Hexagon bolt M10*120	8
8	Earth pipe - left	1
9	Fixing plate	2
10	Back support tube	1
11	Back support tube - left	1
12	Hexagon bolt M10*70	4
13	Hexagon bolt M10*115	2

ASSEMBLY DRAWING

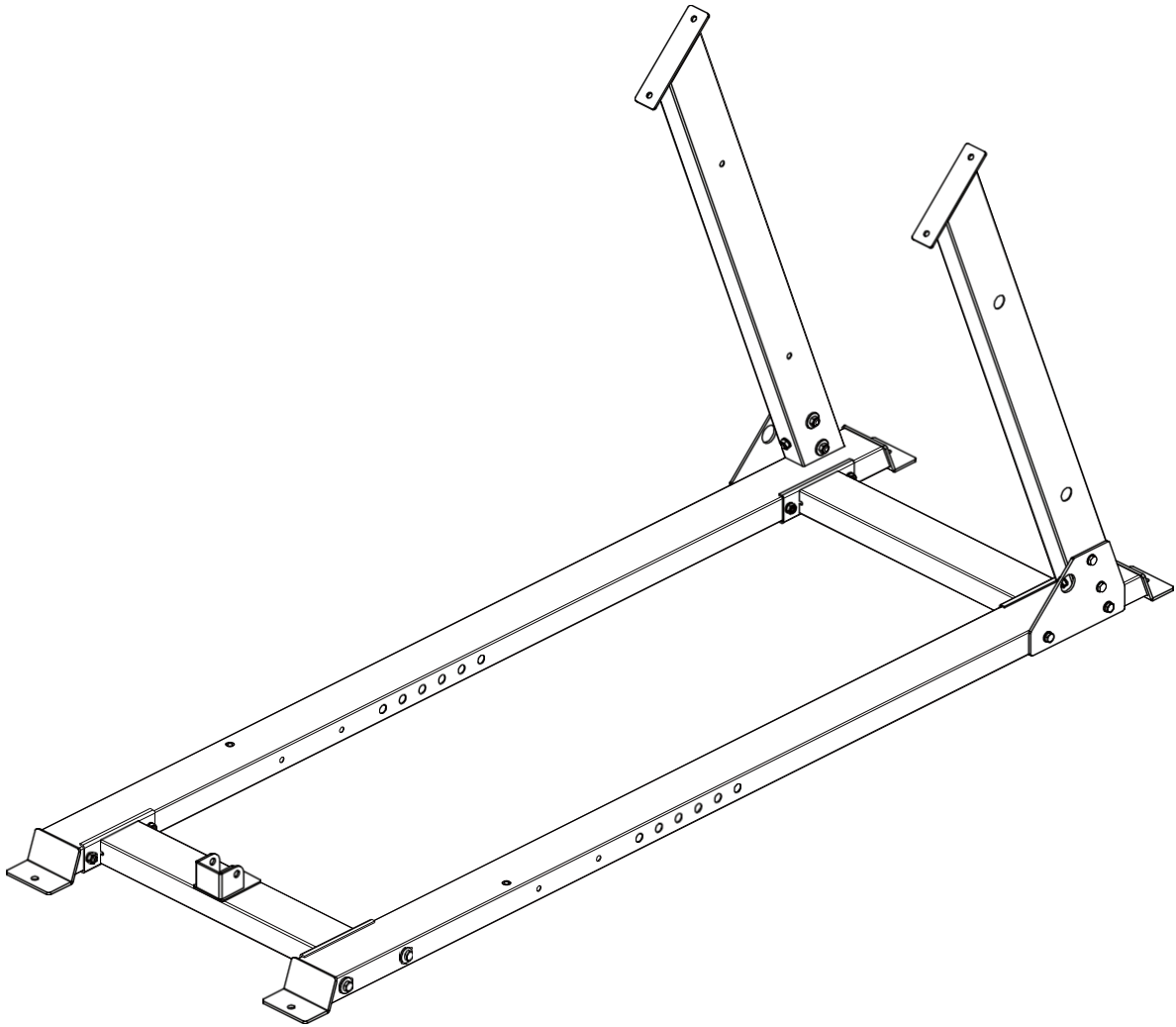

INSTALLATION INSTRUCTIONS IN STEP 1

1. M10*120-7 front grounding tube, $\phi 30*\phi 10*3$ large washer, $\phi 10-5$ washer and M10-6 lock nut are used to connect M10*120-7 hexagon bolt, right grounding tube 1 and left grounding tube 8.
2. The connection of ground connection-3, ground connection right-1 and ground connection left-8 uses M10*120-7 hexagon bolt, $\phi 30*\phi 10*3$ large washer, $\phi 10$ washer on washer-5 and M10 lock nut.
3. Attach the rear support pipe left-11 to the ground pipe left-8 using hexagon bolt M10*115-13, washer $\phi 10-5$, lock nut M10-6 and fixing plate-9.

ASSEMBLY DRAWING

4. Attach the rear carrier pipe-10 to the left ground pipe-8 with a hexagonal

ASSEMBLY

screws M10*115-13, washer 10-5, locknut M10-6 and fixing plate-9.

DRAWING

ASSEMBLY STEP 2

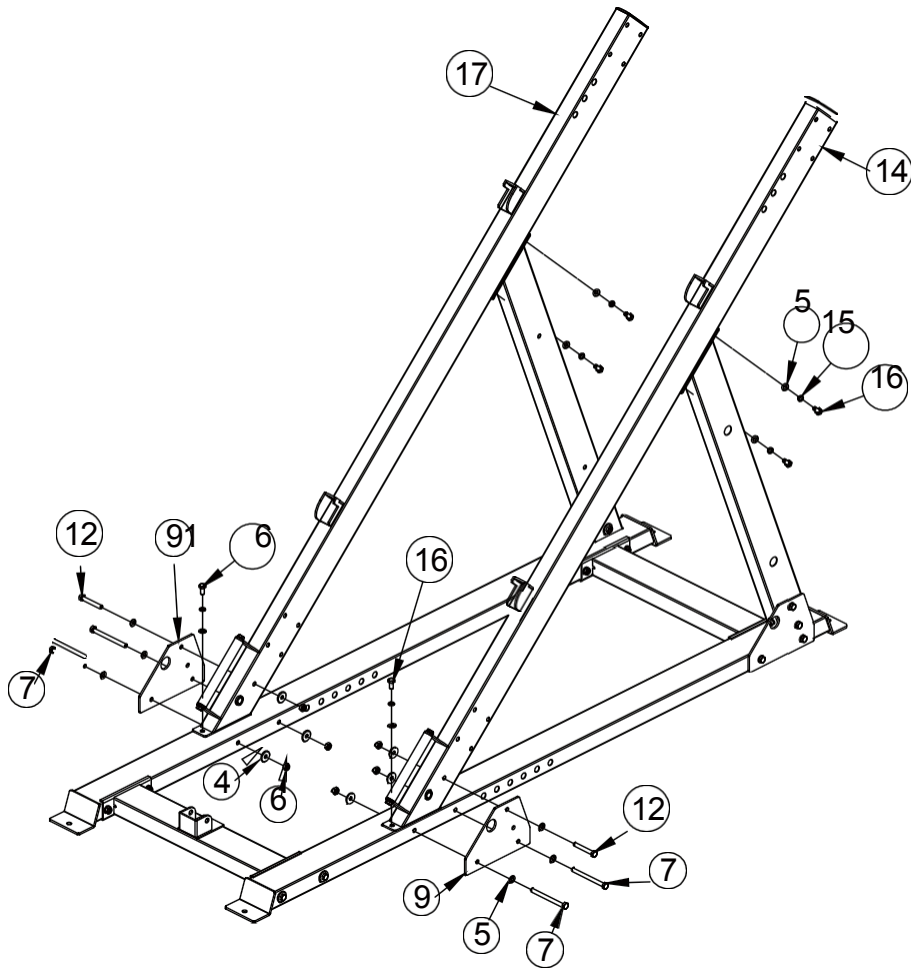

KEY NUMBER	PART DESCRIPTION	QUALITY
4	Large flat washer $\phi 30 \times \phi 10 \times 3$	6
5	Flat washer $\phi 10$	12
6	Locking nut M10	6
7	Hexagon bolt M10*120	4
9	Fixing plate	2
12	Hexagon bolt M10*70	2
14	Inclined pipe Mounting part	1
15	Flexible washer $\phi 10$	6
16	Hexagon bolt M10*20	6
17	Inclined pipe - right part of the assembly	1

ASSEMBLY DRAWING

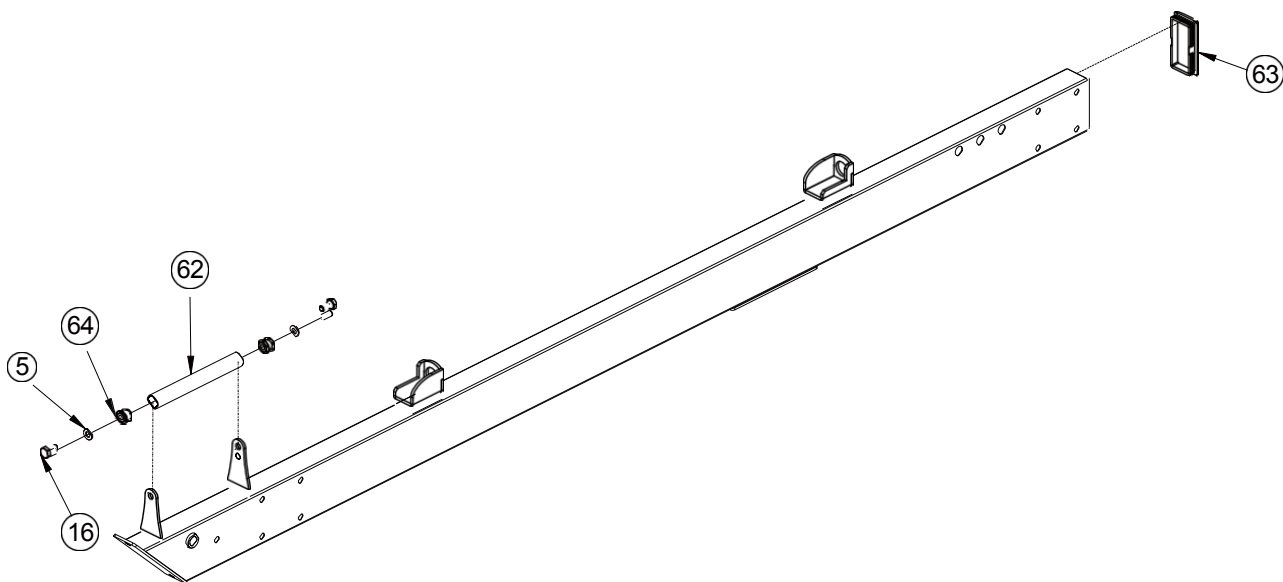

KEY NUMBER	DESCRIPTION OF THE WORK	QUALITY
5	Flat washer $\phi 10$	2
16	Hexagon bolt M10*20	2
62	Handle tube	1
63	Pipe plug 50*100*2	1
91	Double layer spring nut $\phi 29$ -M10	2

ASSEMBLY DRAWING

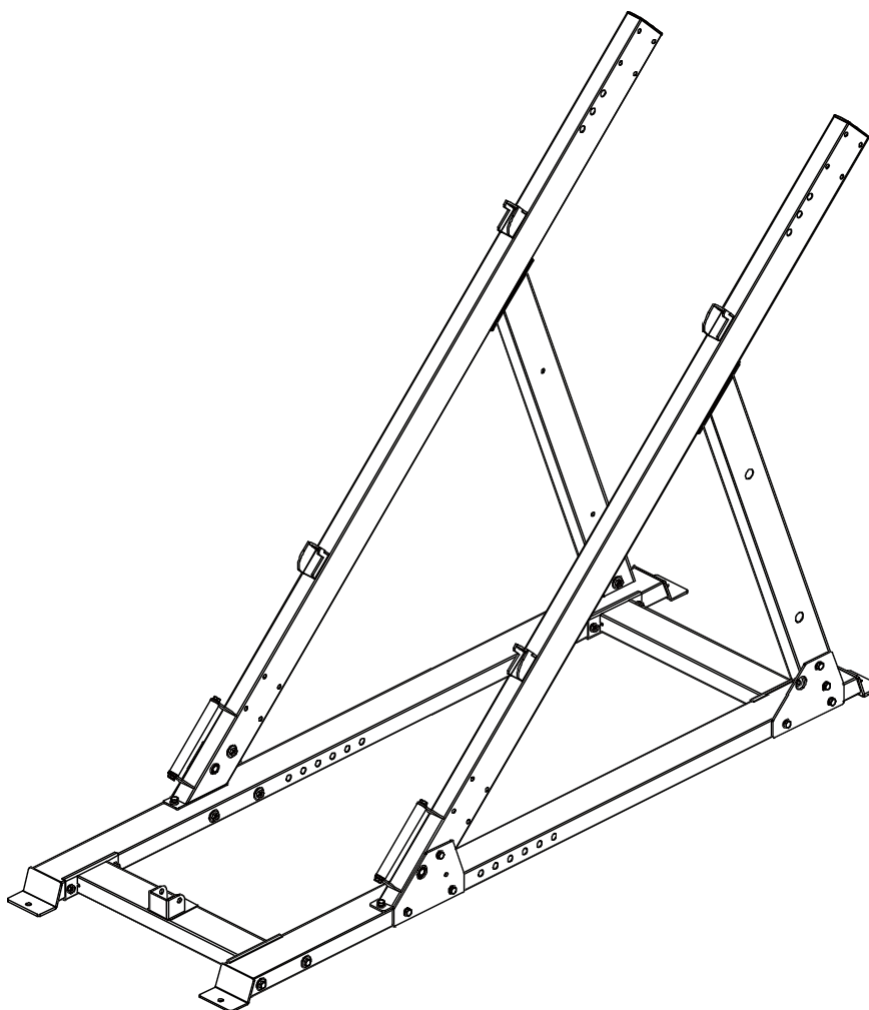

INSTALLATION INSTRUCTIONS IN STEP 2

1. Attach the inclined pipe assembly - part 14 and the inclined pipe assembly - right part 17 to the main frame using M10*120-7 hex bolt, large flat washer $\phi 30*\phi 10*3-4$, flat washer $\phi 10-5$ and M10 bolt.
lock nut-6, fixing plate-9, hexagon bolt M10*20-16 and flexible washer $\phi 10-15$.

ASSEMBLY STEP

3

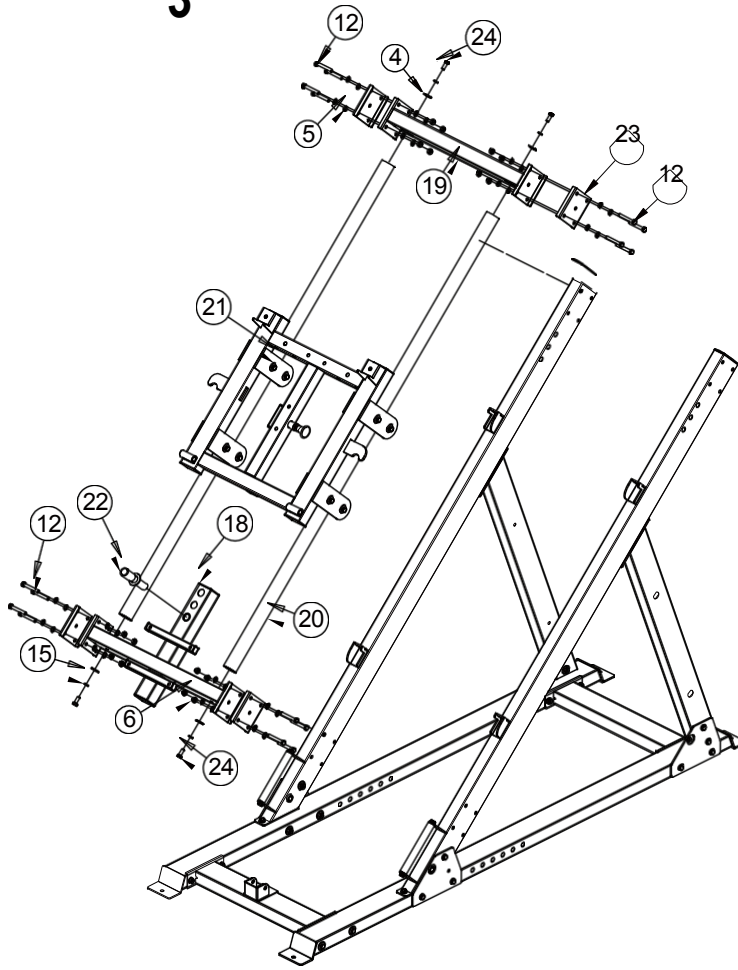

KEY NUMBER	DESCRIPTION OF THE PART	QUALITY
4	Large flat washer $\phi 30 \times \phi 10 \times 3$	4
5	Flat washer $\phi 10$	32
6	Locking nut M10	16
12	Hexagon bolt M10*70	16
15	Flexible washer $\phi 10$	4
18	Guide rod down Fixed tube Mounting part	1
19	Fixed guide part of the pipe installation	1
20	Mounting part of the sliding bar	2
21	Mounting part of the slider frame	1
22	Mounting part of the end rail	1
23	100*130*4 Connecting plate	4
24	Hexagon bolt M10*30	4

ASSEMBLY DRAWING

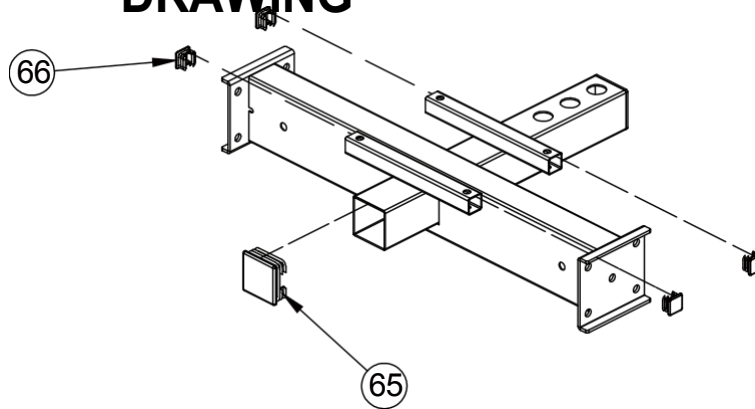

KEY NUMBER	DESCRIPTION OF THE WORK	QUALITY
65	Pipe plug $\phi 60 \times 60 \times 2$	1
66	Pipe plug $\phi 25 \times 25 \times 1,5$	4

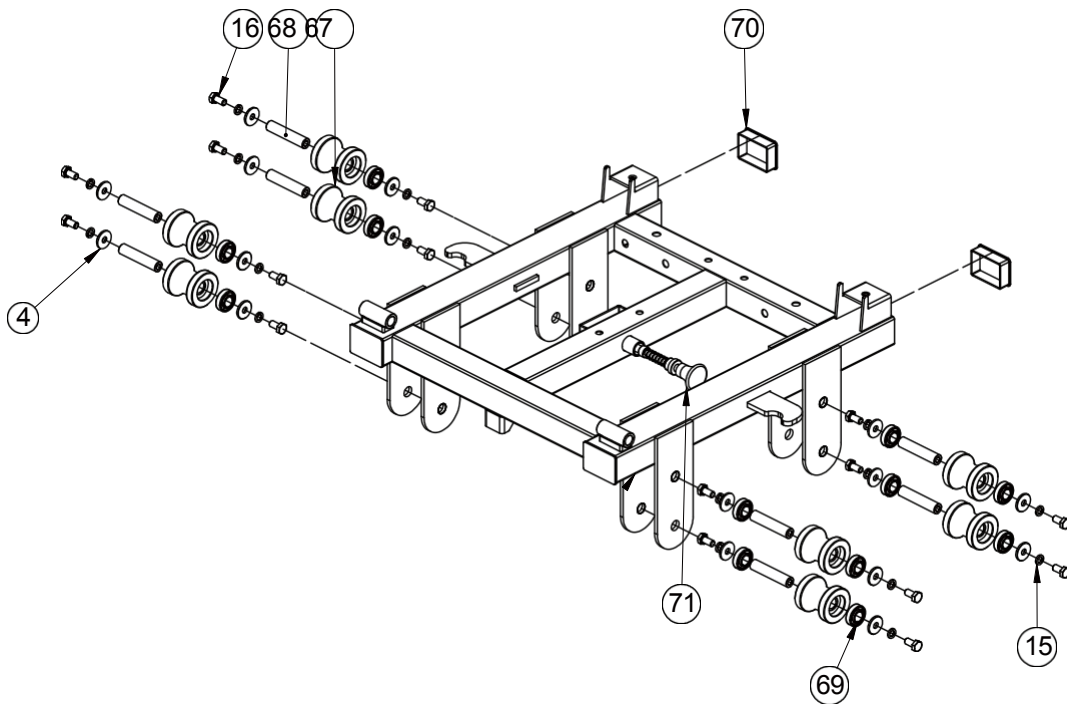

KEY NUMBER	DESCRIPTION OF THE WORK	QUALITY
4	Large flat washer $\phi 30 \times \phi 10 \times 3$	16
15	Flexible washer $\phi 10$	16
16	Hexagon bolt M10*20	16
67	Roller $\phi 59$	8
68	Inner axis threaded $\phi 17 \times 81 \text{-M10}$	8
69	Bearing 6003	16
70	Plug $50 \times 70 \times 2$	2
71	Pull the pin	1

ASSEMBLY DRAWING

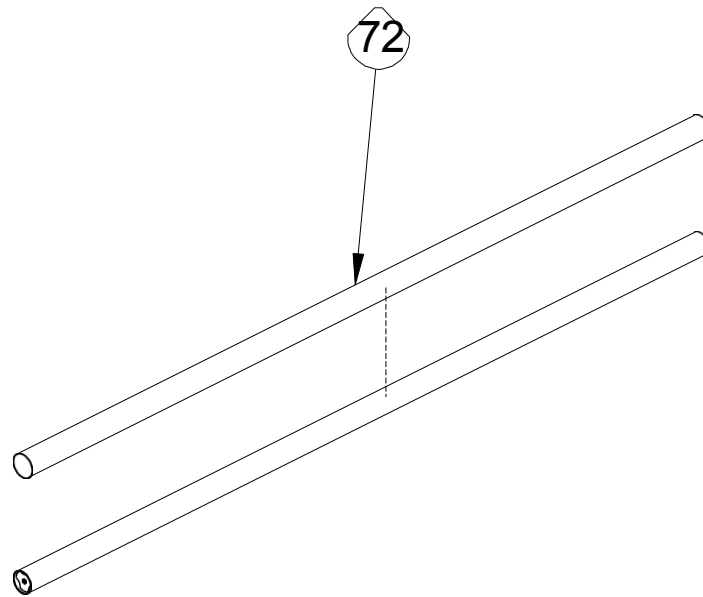

KEY NUMBER	DESCRIPTION OF THE WORK	QUALITY
72	Stainless steel bar $\varphi 50 \times 0,8$	1

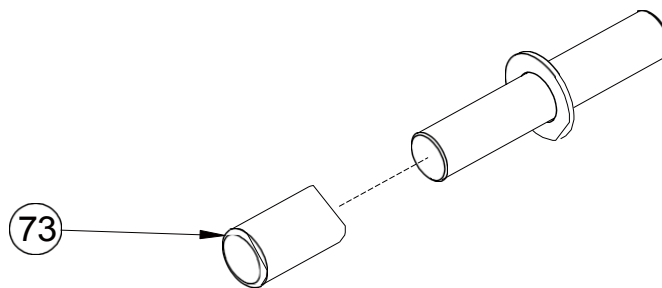

KEY NUMBER	DESCRIPTION OF THE WORK	QUALITY
73	Pipe cover $\varphi 30 \times \varphi 25 \times 50$	1

ASSEMBLY DRAWING

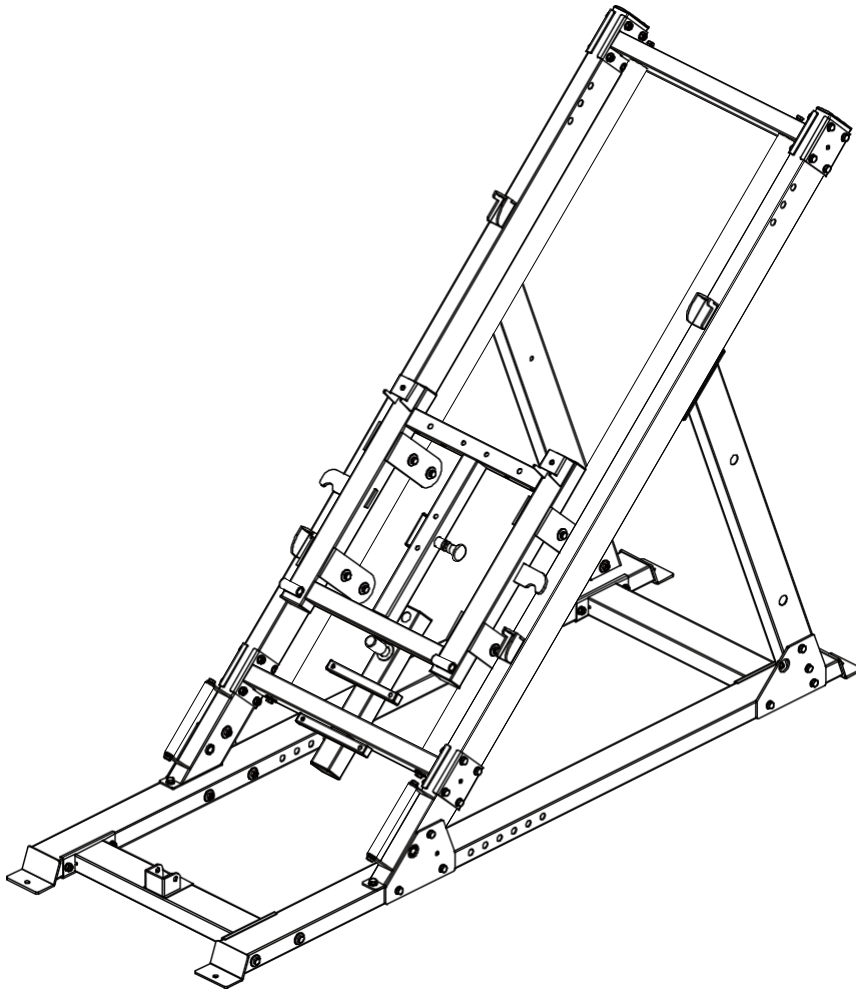

INSTALLATION INSTRUCTIONS IN STEP 3

1. Attach the guide rod down to the fixed tube assembly part 18 to the main frame with M10*70-12 hex bolt, ϕ 10-5 flat washer and M10-6 lock nut and 100*130*4 connection plate.
2. Attach the slide bar assembly, part 20, to the guide bar down on the fixed tube, part 18, using an M10*30-24 hex bolt, a ϕ 10-15 flexible washer, and a large ϕ 30* ϕ 10*3-4 flat washer.
3. Insert the slide frame assembly, part 21, into the slide bar assembly, part 20.
4. Attach the fixed guide bar assembly - part 19 to the main frame using M10*70-12 hex bolt, ϕ 10-5 flat washer and M10-6 lock nut and 100*130*4 connection plate.

ASSEMBLY

5. Attach the slide bar assembly, part 20, to the fixed guide bar assembly, part 19, using an M10*30-24 hex bolt, a $\phi 10-15$ flexible washer, and a large $\phi 30*\phi 10*3-4$ flat washer.

DRAWING

ASSEMBLY STEP

4

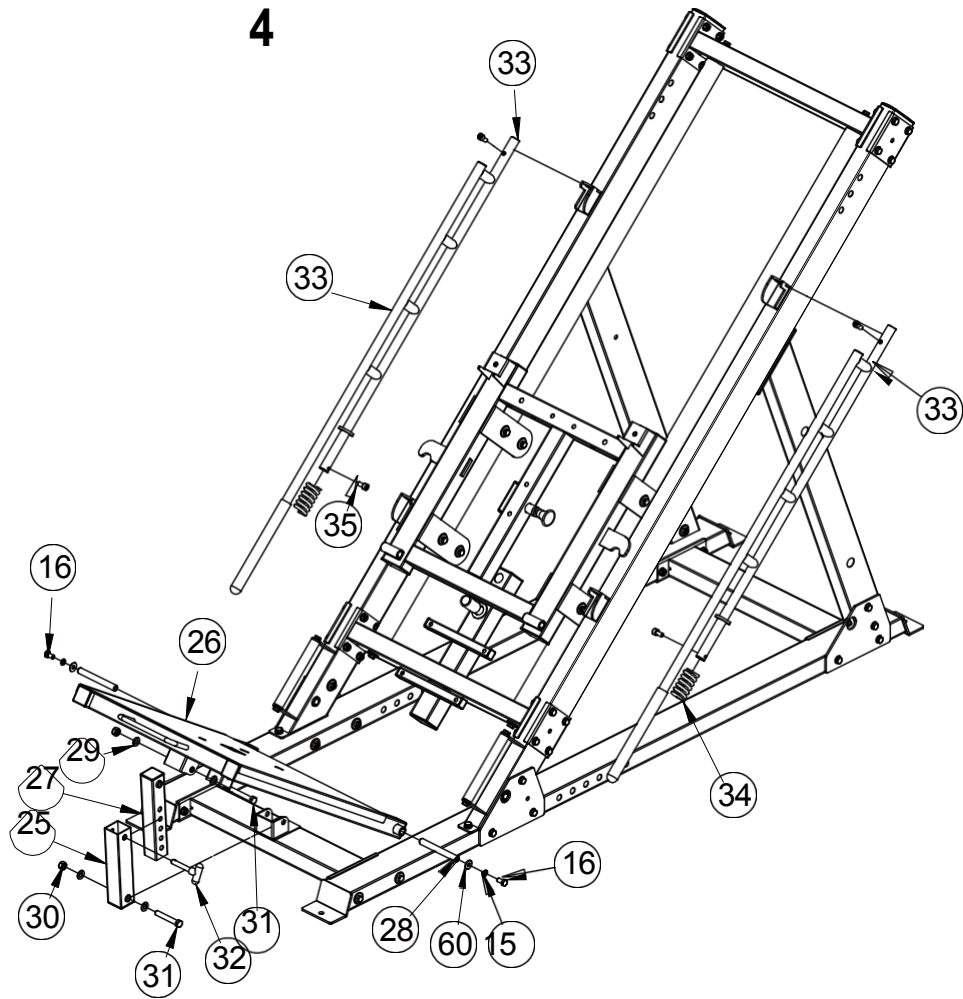

KEY NUMBER	DESCRIPTION OF THE WORK	QUALITY
15	Flexible washer $\phi 10$	4
16	Hexagon bolt M10*20	4
25	External setting tube assembly of the foot press	1
26	Footstool	1
27	Leg press adjustment assembly	1
28	Axle with internal thread $\phi 15,9 \times 135$	2
29	Flat washer $\phi 12$	4
30	Locking nut M12	2
31	Hexagon bolt M12*80	2
32	T-shaped pin	1
33	Part of the end frame assembly	2
34	Spring	2
35	Hexagon head screws M10*20	4
60	Large flat washer $\phi 25 \times \phi 10 \times 2$	4

ASSEMBLY DRAWING

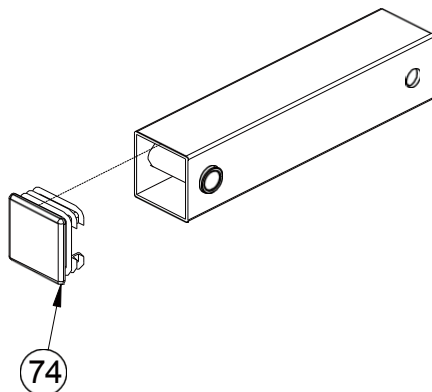

KEY NUMBER	DESCRIPTION OF THE WORK	QUALITY
74	74 Pipe plug $\phi 50 \times 50 \times 2$ 1	1

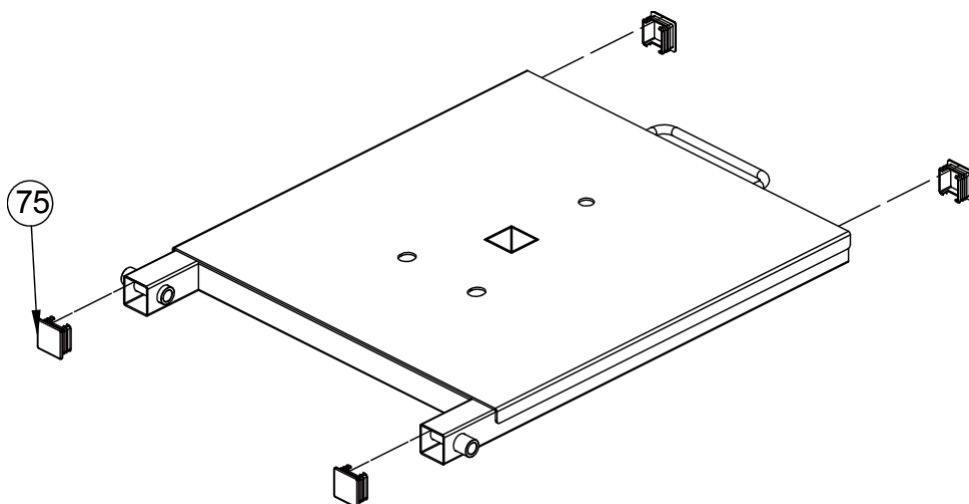

KEY NUMBER	DESCRIPTION OF THE WORK	QUALITY
75	Tube plug $\phi 45 \times 45 \times 2$	4

ASSEMBLY DRAWING

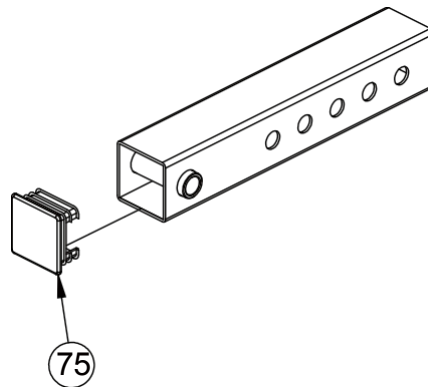

KEY NUMBER	PART DESCRIPTION	QUALITY
75	Tube plug $\varnothing 45 \times 45 \times 2$	4

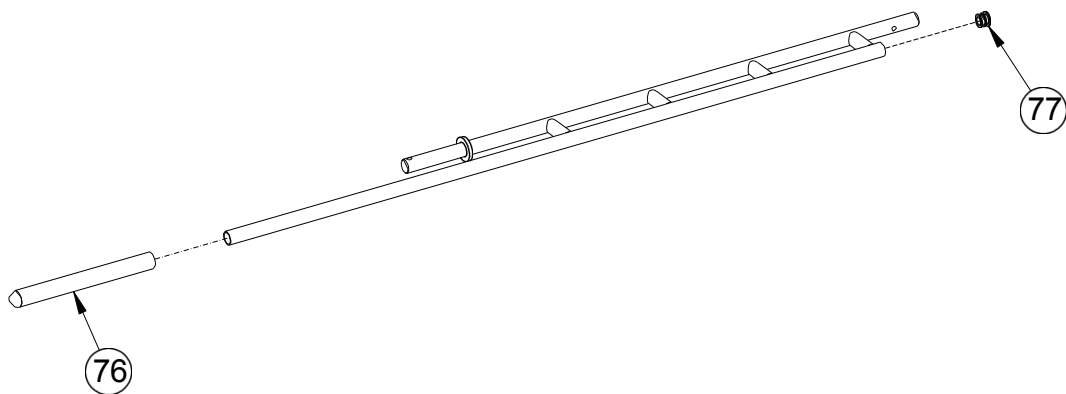

KEY NUMBER	DESCRIPTION OF THE WORK	QUALITY
76	Handle cover $\varnothing 24,5 \times 280$	1
77	Round plug $\varnothing 25 \times 2$	1

ASSEMBLY DRAWING

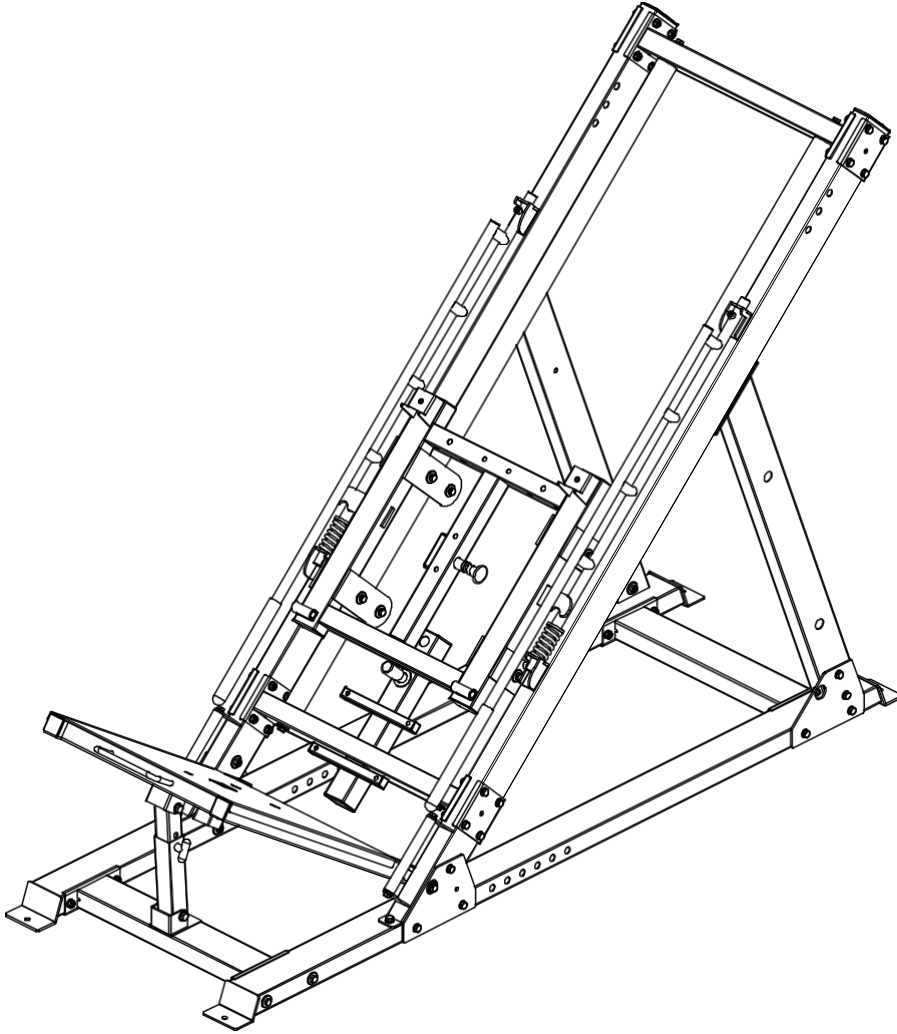

INSTALLATION INSTRUCTIONS IN STEP 4

1. Attach the end frame assembly, part 33, to the main frame using spring 34 and M10*20-35 hex head screws.
2. Attach the leg press outer tube assembly - part 25 to the main frame using M12*80 hex bolt - 31, flat washer $\phi 12$ - 29, lock nut M12 - 30.
3. Attach the leg press adjusting tube assembly - part 27 to the leg plate - 26 using hexagon bolt M12*80 - 31, $\phi 12$ flat washer-29, lock nut M12-30.
4. Attach the floor plate-26 to the main frame with M10*20-16 hex bolt, $\phi 10$ -15 flexible washer, $\phi 25$ * large flat washer $\phi 10$ *2-60 and $\phi 15.9$ *135 internal threaded axle.

ASSEMBLY DRAWING

5. Connect the outer tube assembly for the leg press setup from section 25 and the tube assembly for the

ASSEMBLY DRAWING

adjustment of the foot part of the press 27 by means of a T-32 shaped pin.

ASSEMBLY STEP

5

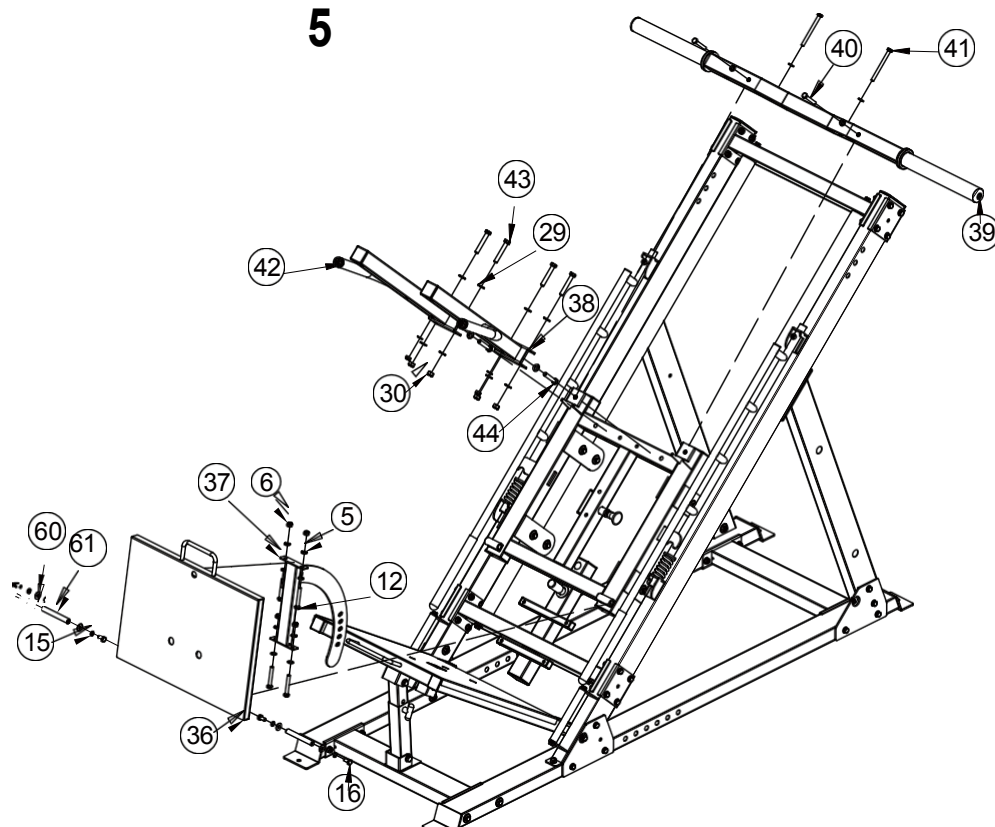

KEY NUMBER	PART DESCRIPTION	QUALITY
5	Flat washer $\phi 10$	14
6	Locking nut M10	6
12	Hexagon bolt M10*70	4
15	Flexible washer $\phi 10$	4
16	Hexagon bolt M10*20	4
29	Flat washer $\phi 12$	10
30	Locking nut M12	4
36	Mounting plate upside down Part	1
37	Mounting part of the Regulatory Fixing Pipe	1
38	Shoulder pads Frame - right mounting part	1
39	Dumbbell holder frame	1
40	Hexagon bolt M10*65	2
41	Hexagon bolt M10*115	2
42	Shoulder pads Frame - left mounting part	1
43	Hexagon bolt M12*75	4
44	Hexagon bolt M12*65	2
60	Large flat washer $\phi 25 * \phi 10 * 2$	4
61	Axle with internal thread $\phi 15,9 * 120$	2

ASSEMBLY DRAWING

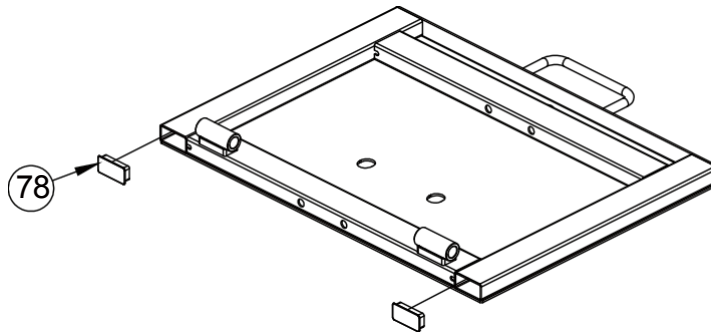

KEY NUMBER	DESCRIPTION OF THE WORK	QUALITY
78	Pipe plug $\varnothing 25 \times 25 \times 1,5$	2

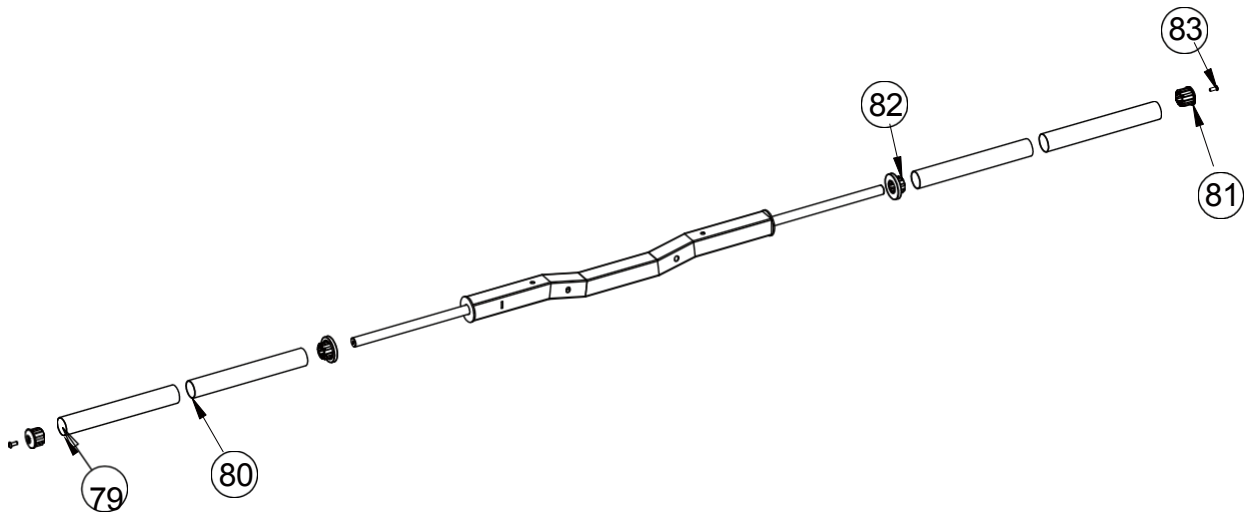

KEY NUMBER	DESCRIPTION OF THE WORK	QUALITY
79	$\varnothing 50 \times 345$ Stainless steel pipe $\varnothing 49,5 \times 6$	2
80	$\varnothing 48 \times 344$ Inner tube $\varnothing 48 \times 1,5$	2
81	End cap $\varnothing 50 \times \varnothing 44,8 \times \varnothing 25,5$	2
82	Middle cap $\varnothing 70 \times 44,8 \times \varnothing 25,5 \times 30$	2
83	Hexagon head screws M8*20	2

ASSEMBLY DRAWING

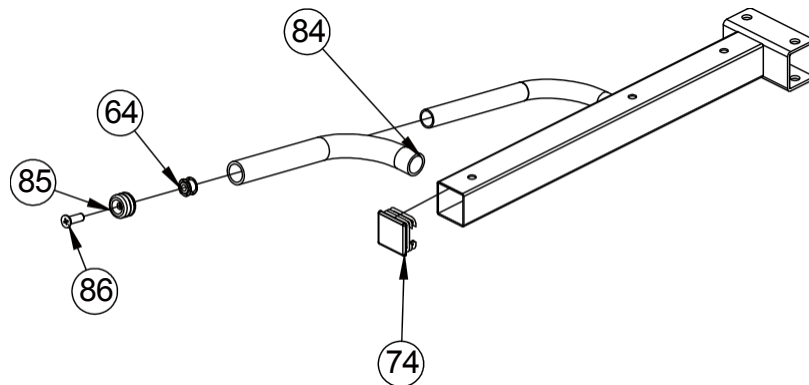

KEY NUMBER	DESCRIPTION OF THE WORK	QUALITY
64	Double layer spring nut $\varnothing 23\text{-M10}$	1
74	Pipe plug $\varnothing 50\text{*}50\text{*}2$	1
84	Handle cover $\varnothing 32\text{*}310$	1
85	Fixing ring $\varnothing 31,5\text{*}\varnothing 25,5$	1
86	Screw with countersunk head M10*25	1

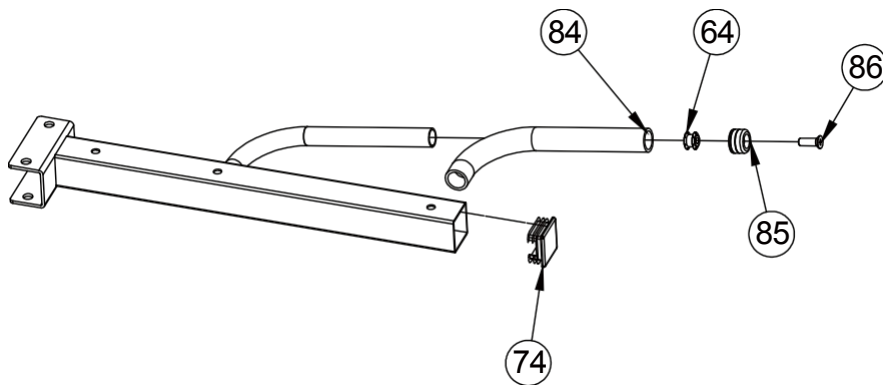

KEY NUMBER	DESCRIPTION OF THE WORK	QUALITY
64	Double layer spring nut $\varnothing 23\text{-M10}$	1
74	Pipe plug $\varnothing 50\text{*}50\text{*}2$	1
84	Handle cover $\varnothing 32\text{*}310$	1
85	Fixing ring $\varnothing 31,5\text{*}\varnothing 25,5$	1
86	Screw with countersunk head M10*25	1

ASSEMBLY DRAWING

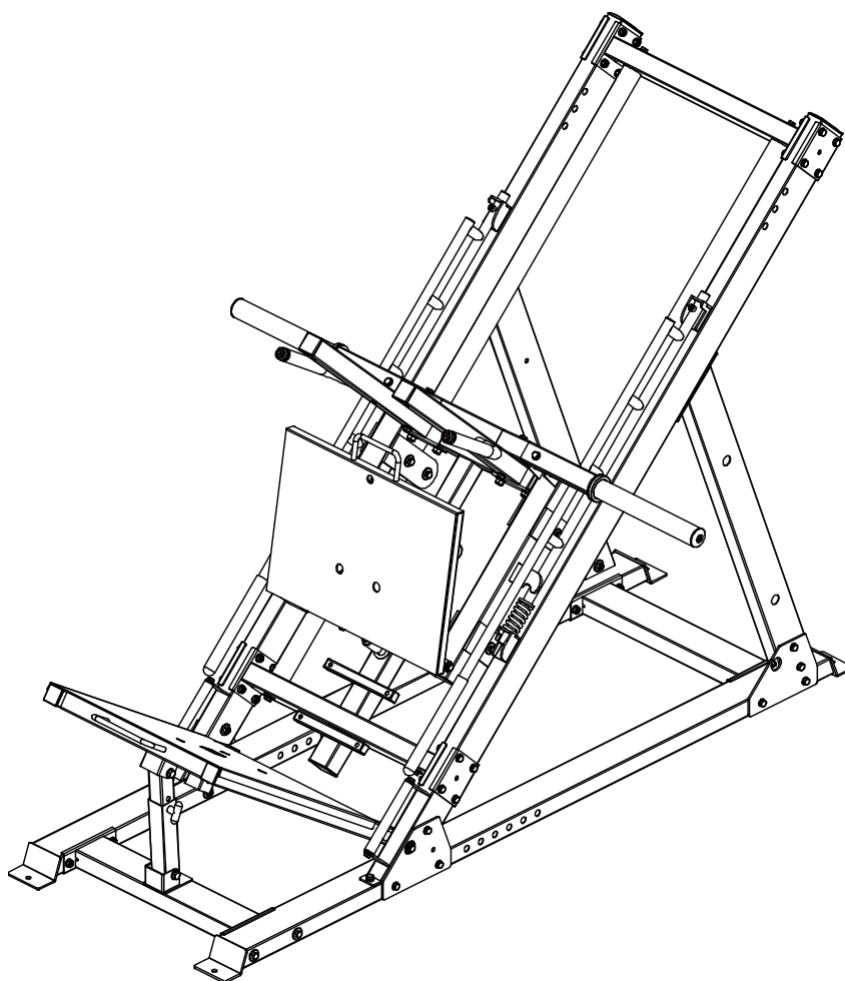

INSTALLATION INSTRUCTIONS IN STEP 5

1. Fix the frame shoulder pads - left part of the assembly-42 and the frame shoulder pads - right part of the assembly-38 to the main frame using hexagon bolt M12*75-43, flat washer $\phi 12-29$, lock nut M12-30 and hexagon bolt M12*65-44.
2. Fix the dumbbell holder-39 frame to the main frame with M10*65-40 hex bolt, M10*115-41 hex bolt, $\phi 10-5$ flat washer and M10-6 lock nut.
3. Using the hex bolt M10*70-12, flat washer $\phi 10-5$ and lock nut vM10- 6, attach the dumbbell holder frame-39 to the leg plate assembly-36.
4. Attach the footplate mounting plate part-36 to the main frame with a hexagonal

ASSEMBLY

screw M10*20-16, flexible washer $\phi 10$ -15, large flat washer $\phi 25$ * $\phi 10$ *2-60 and axles with

DRAWING

internal thread $\varphi 15,9 \times 120 \pm 0,01$

ASSEMBLY DRAWING

ASSEMBLY STEP

6

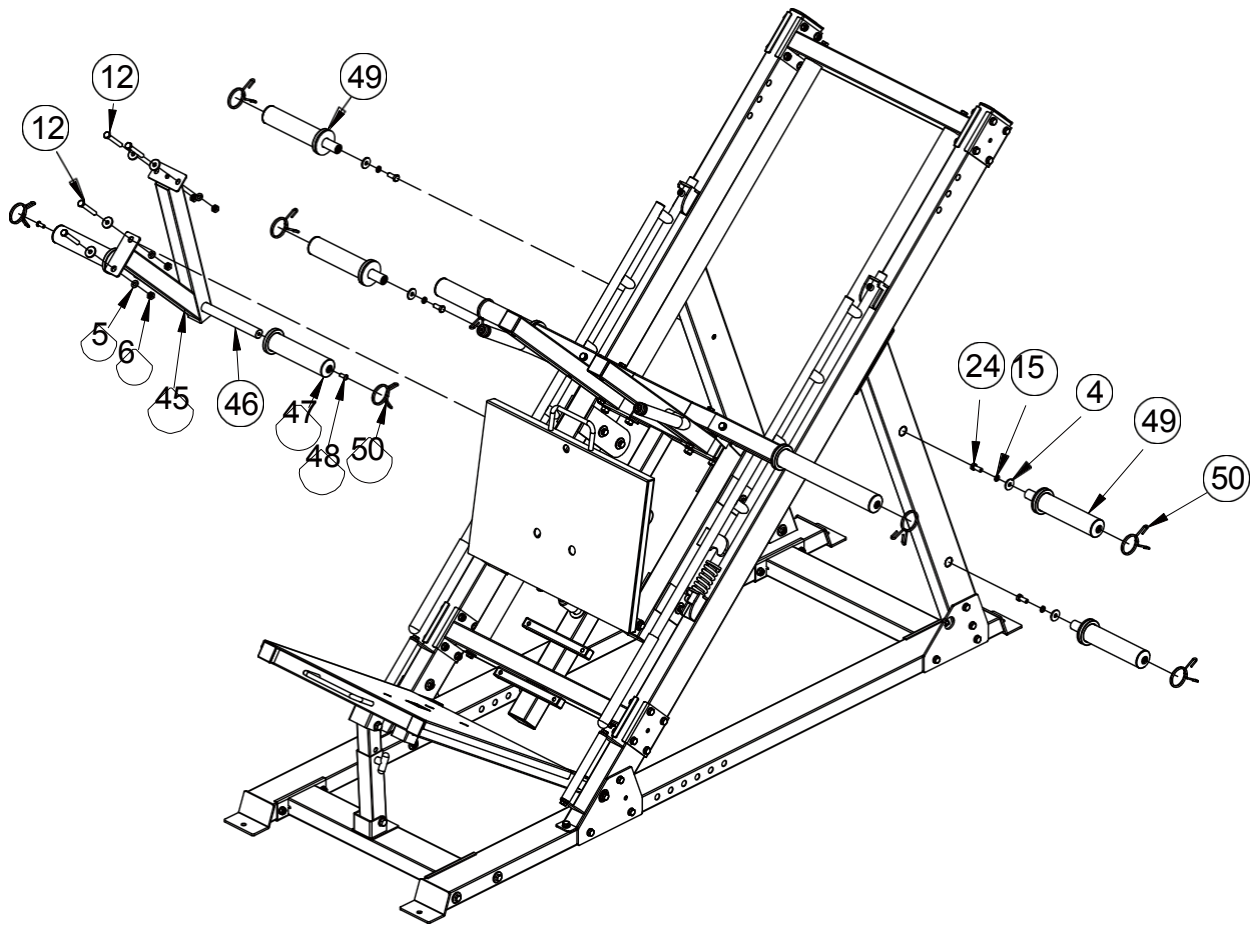

KEY NUMBER	DESCRIPTION OF THE WORK	QUALITY
4	Large flat washer $\phi 30 \times \phi 10 \times 3$	8
5	Flat washer $\phi 10$	4
6	Locking nut M10	4
12	Hexagon bolt M10*70	4
15	Flexible washer $\phi 10$	4
24	Hexagon bolt M10*30	4
45	Part of the lifting frame assembly	1
46	Inner bar for dumbbells	1
47	Holder for dumbbells	2
48	Hexagon head screws M8*20	2
49	Holder for dumbbells	4
50	Spring collar	8

ASSEMBLY DRAWING

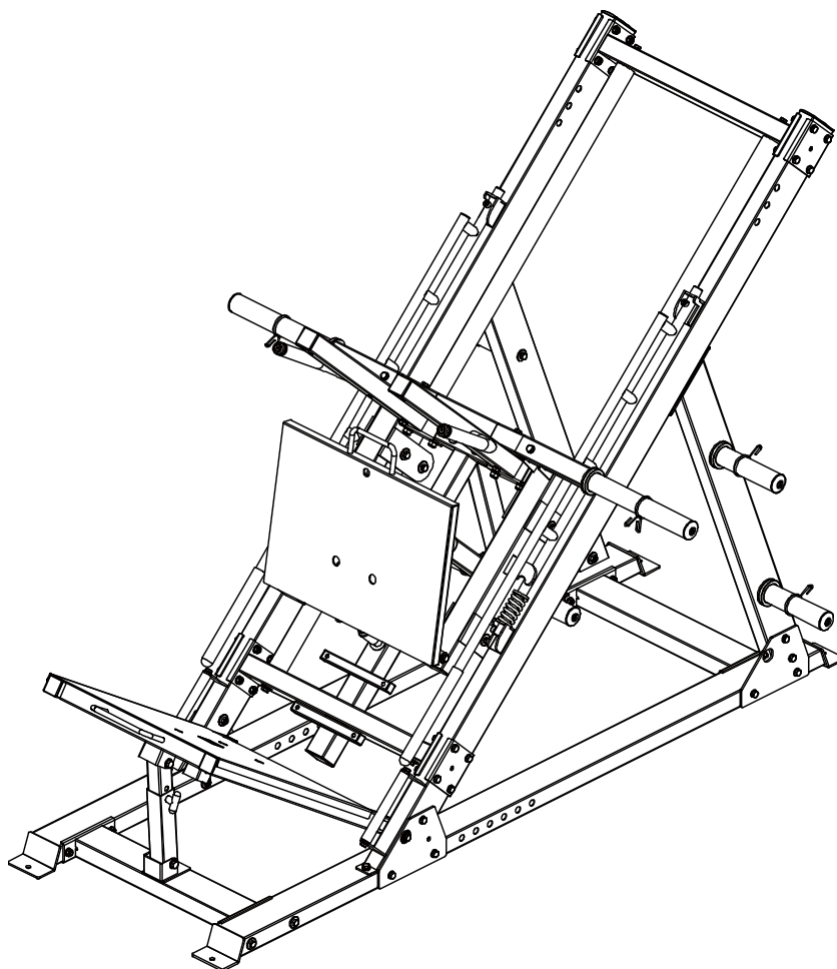

INSTALLATION INSTRUCTIONS IN STEP 6

1. Attach the lifting frame assembly, part 45, to the frame using hex bolt M10*70-12, flat washer $\phi 10-5$, large flat washer $\phi 30*\phi 10*3-4$ and lock nut vM10-6.
2. Attach the inner bar of the dumbbell-46 to the mounting part of the lifting frame-45 using M8*20-48 hex head screws and the dumbbell-47 plate holder.
3. Attach the dumbbell-49 holder to the main frame with an M10*30-24 hex bolt, a $\phi 10-15$ flexible washer and a large flat washer $\phi 30*\phi 10*3-4$.
4. Fit the spring collar to the main frame.

ASSEMBLY STEP

7

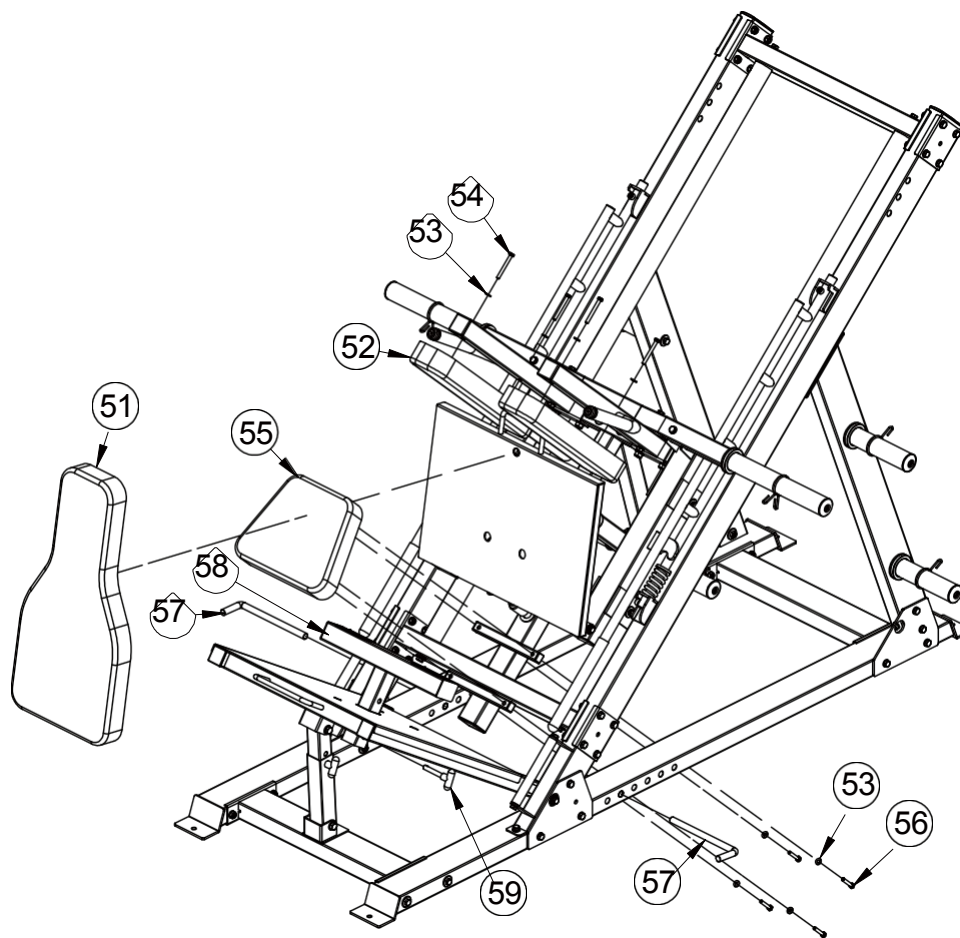

KEY NUMBER	DESCRIPTION OF THE WORK	QUALITY
51	Rear pad	1
52	Shoulder pad	2
53	Flat washer $\varnothing 8$	8
54	Hexagon bolt M8*70	4
55	Seat pad	1
56	Hexagon bolt M8*45	4
57	Peg Band	2
58	Legs Brick frame	1
59	T-shaped pin	1

ASSEMBLY DRAWING

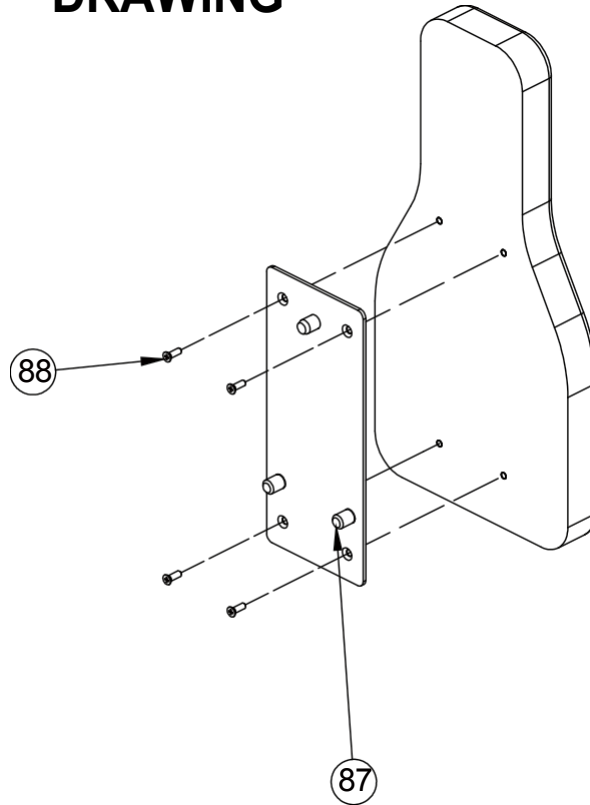

KEY NUMBER	DESCRIPTION OF THE PART	QUALITY
87	Rear washer fixing plate	1
88	Screw with countersunk head M8*20	4

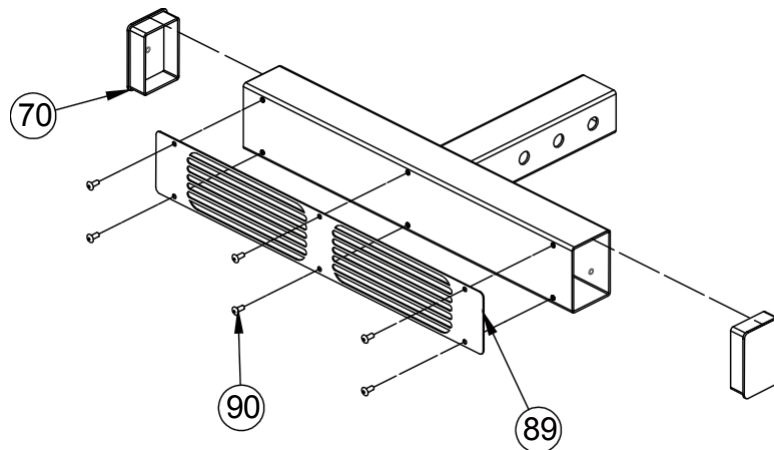

KEY NUMBER	JOB DESCRIPTION	QUALITY
70	Plug 50*70*2	2
89	Anti-slip film	2

ASSEMBLY

DRAWING

90

Flat Head Machine Screw round head 4*10

6

ASSEMBLY DRAWING

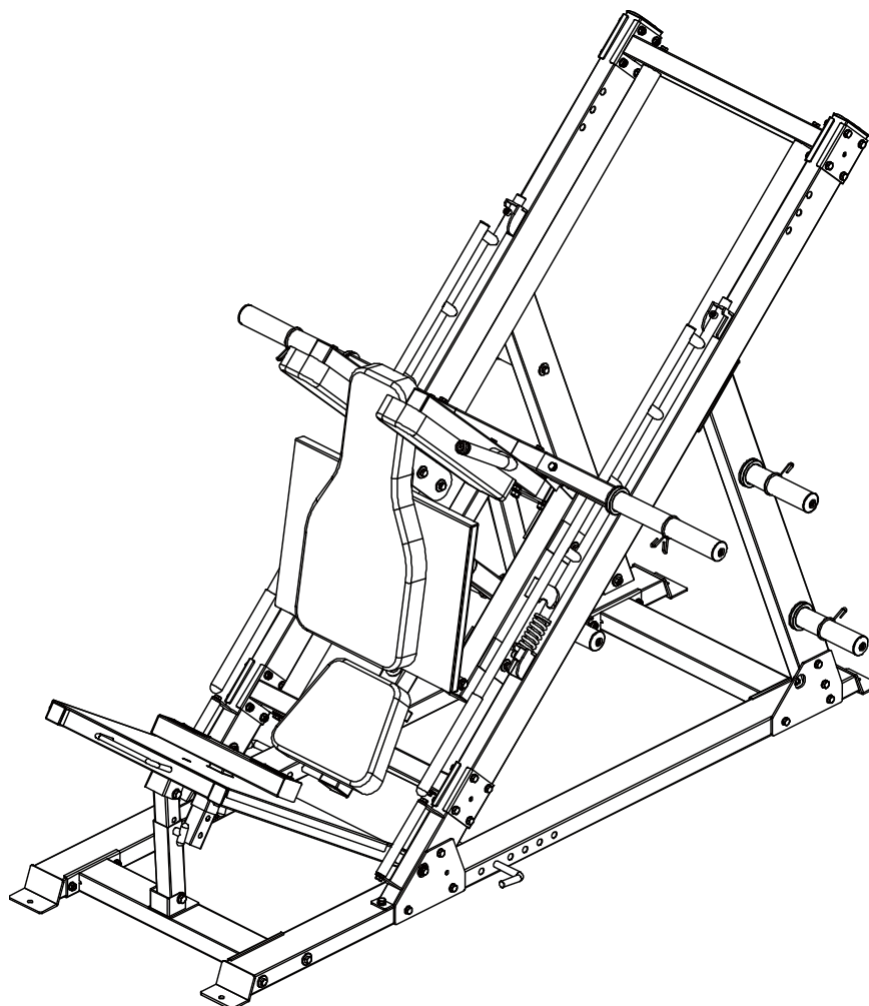

INSTALLATION INSTRUCTIONS STEP 7

1. Attach the seat pad-55 to the main frame using the M8*45-56 hex bolt and flat washer ϕ 8-53.
2. Attach the shoulder pad-52 to the main frame using the M8*70-54 hex bolt and flat washer ϕ 8-53.
3. Place the rear pad-51 on the mounting plate with the feet of part-36.
4. Place the foot brick-58 on the bottom foot plate-26. Use a ϕ 12*70 t-59 pin.

ASSEMBLY DRAWING

5. Attach strap pin-57 to the main frame.