

# FORCE <sup>USA</sup> PRO

## G20 ALL-IN-ONE-TRAINER

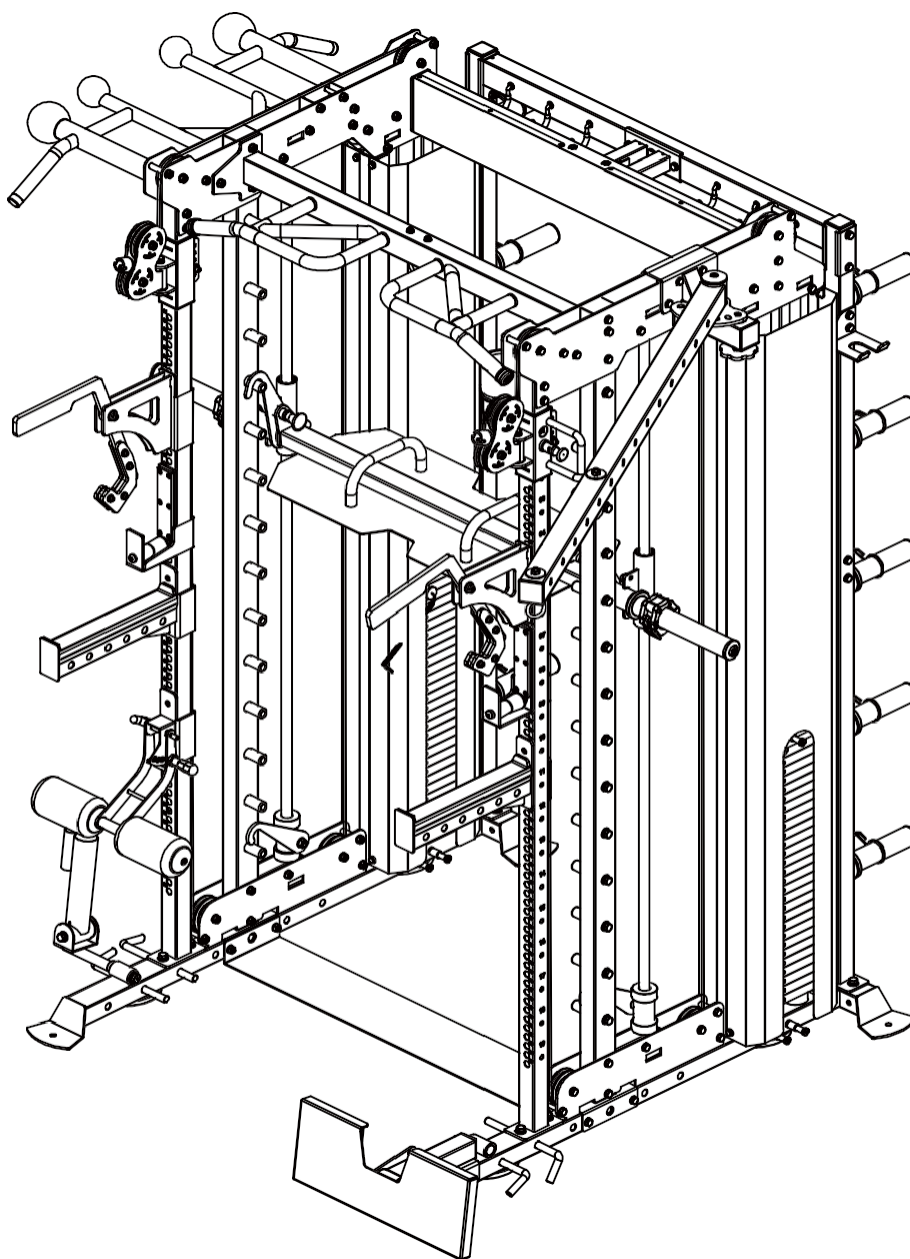

OWNERS MANUAL | F-G20-V2

# TABLE OF CONTENTS

Parts List	2-21
Assembly Step 1	22-25
Assembly Step 2	26-30
Assembly Step 3	31-33
Assembly Step 4	34-36
Assembly Step 5	37-42
Assembly Step 6	43-44
Assembly Step 7	45-47
Assembly Step 8	48-49
Assembly Step 9	50-53
Assembly Step 10	54-57
Assembly Step 11	58-61
Assembly Step 12	62-64
Assembly Step 13	65-68
Assembly Step 14	69-77
Cable Attachments	78
Spare Parts Drawing	79-82

# PARTS LIST

KEY NUMBER	DESCRIPTION OF PART	QUANTITY
1	Ground Tube	2
2	Front Guide Rod $\phi 25 \times 2050$	6
3	Left Stand Tube	1
4	Connect Support Tube T3	1
5	Right Stand Tube	1
6	Crush Pad $\phi 60 \times \phi 27 \times 42$	4
7	Hexagon Bolt M10*95	8
8	Flat Washer(Gb) $\phi 10$	6
9	Lock Nut M10	98
10	Hexagon Bolt M10*70	16
11	Hang Shape $\phi 17.8 \times 17$ -M12	16
12	Hexagon Bolt M10*16	14
13	Silding Sleeve Welding	2
14	Barbell Rod	1
15	Safety Hook Right	1
16	Rubber Pad $\phi 60 \times \phi 26 \times 25$	4
17	Safety Hook Left	1
18	Ship Rod	1
19	Weight Stack	2
20	Spring Collar 28	2
21	Magnetic Pull Pin $\phi 10 \times 100$	2
22	Hexagon Bolt M10*20	14
23	Spring Gasket $\phi 10$	24
24	Counterweight Block Pulley Frame	2
25	Chin Bar	2

# PARTS LIST

KEY NUMBER	DESCRIPTION OF PART	QUANTITY
26	Connecting Piece - Two Holes T3.0*50*120	2
27	Up Decoate Plate T5	4
28	Back Chin Up Bar	1
29	Hexagon Bolt M10*80	13
30	Hexagon Bolt M10*75	45
31	Stainless Steel Guide Rod Left	1
32	The Birds Sliding Sleeve Right	1
33	Stainless Steel Guide Rod Right	1
34	The Birds Sliding Sleeve Left	1
35	Across Connected Plate	1
36	Spring Washer $\phi$ 12	40
37	Flat Washer $\phi$ 2	42
38	Hexagon Bolt M12*25	34
39	Decorative Plate Support Tube $\phi$ 4*1.5*49	6
40	Decorative Plate Of Bottom Beam T5	4
41	Powder Set $\phi$ 20* $\phi$ 16* $\phi$ 10.5*20.5	24
42	Pulley $\phi$ 92	19
43	Hexagon Bolt M10*25	12
44	Wire Rope-Nose	2
45	Back Shield T1	4
46	Shield Of Edge 32*1975	4
47	Flat Washer $\phi$ 8	42
48	Hexagon Bolt M8*16	16
49	Barbell Rod Sleeve	2
50	Core Trainer with Rotating Holder	1



# PARTS LIST

KEY NUMBER	DESCRIPTION OF PART	QUANTITY
51	Band Pegs	4
52	Olympic Lock Collar	2
53	Hexagon Socket Flat Round Head Screws M12*40	2
54	Back Up Connection Tube	1
55	Pull Up The Beam Welder	1
56	Hook	6
57	Rear Column	2
58	Concave Plate T3*120*58	2
59	Lock Nut M8	16
60	Weight Plate Sleeve	10
61	Barbell Holder	1
62	Small Handle Fix Tube	1
63	Globe Chin Up Bar	1
64	Spring Collar	10
65	Right Front Safety	1
66	Left Front Safety	1
67	Leg Press Plate	1
68	Swing Arm Fixed Reinforcement Plate T6	1
69	Left Mono Lift	1
70	Right Mono Lift	1
71	Left Roller J-Hook	1
72	Right Roller J-Hook	1
73	Ground Pipe Welds	2
74	Knee Anchor J-Hook	1
75	Lat Pulldown Knee Anchor	1

# PARTS LIST

KEY NUMBER	DESCRIPTION OF PART	QUANTITY
76	T Shape Pin-Black $\phi 10 \times 100$	1
77	Square Tube Plug $25 \times 50 \times 1.5$	6
78	Oval Ring $131 \times 80$	4
79	Countersunk Hexagon Rivet Nuts M10	10
80	Hexagon Bolt M10*90	4
81	Hang Shaft	28
82	$50 \times 70 \times 1.5$ Square Tube Plug $50 \times 70 \times 1.5$	2
83	50 Square Tube Plug $50 \times 50 \times 2$	6
84	Rubber Cover $\phi 21 \times 35$	2
85	Lining Bearing $\phi 40 \times \phi 25 \times 58$	6
86	Bearing 6005	4
87	Spring Catch Collar $\phi 40$	8
88	Hexagon Socket Cap Screws M6*16	4
89	Hook Right	1
90	Barbell Aluminum Rod $\phi 30 \times \phi 25.1 \times 1056$	1
91	Barbell Inner Rod $\phi 25 \times 1857$	1
92	Spring Washer $\phi 6$	4
93	Hook Left	1
94	Safety Hook Welding	2
95	Safety Hook T8	2
96	Lock Nut M12	2
97	Hexagon Bolt M10*45	8
98	Hexagon Nut M12	2
99	Ankle Cuff	1
100	Decorate Plate T1	1

# PARTS LIST

KEY NUMBER	DESCRIPTION OF PART	QUANTITY
101	Mushroom Head Break Mandrel Blind Rivets 4*8	12
102	Bush Bearing 50-60 4	4
103	Aluminum Spring Pin M20*1.5-φ10	2
104	Pulley Rotation Cover	2
105	Powder Set φ33*φ29*φ20*18	4
106	Inner Shaft φ20*67	2
107	Hanging Ring Weldment	1
108	Circle Tube Plug φ32*1.5	10
109	Handle Cover φ38*φ32*130	2
110	Outer Catch Collar φ8*32*25	2
111	Hexagon Socket Set Screw M10*25	2
112	Double Shrapnel Nut φ29.3-M10	2
113	Aluminum Inner Catch Collar φ60*27	2
114	Stainless Outer Tube φ49.5*0.6	2
115	Barbell Bar Plug φ50*37	2
116	Inside Tube Of Barbell Rod φ48*2.5	2
117	Rubber Ring φ70*φ50*φ10	12
118	New Rotation Rod	1
119	Powder Set φ50*φ47*φ25*15	2
120	Circle Tube Inner Plug φ25*2	1
121	Double Barbell Rotation	1
122	Inner Shaft φ25*77*M12	1
123	Barbell Bar Plug φ25*86	1
124	Barbell Bar Limit Shaft φ22*39.5	1
125	Limit Ring φ25*φ20*5	1

# PARTS LIST

KEY NUMBER	DESCRIPTION OF PART	QUANTITY
126	Back Connection Tube	1
127	Hook	6
128	Hook Handle Cover $\Phi 8 \times 100$	6
129	129 Back Stand Tube	2
130	Kettle Frame $\Phi 100 \times 90$	1
131	1x Plate T4	1
132	M6*10hexagon Socket Set Screw M6*10	3
133	Small Handle	1
134	Rubber Ring $\Phi 59 \times \Phi 39 \times 19$	1
135	$\Phi 8 \times 45$ hook Handle Cover $\Phi 8 \times 45$	2
136	Barbell Bar Tube	10
137	Decorative Aluminum Cover $\Phi 1 \times \Phi 18 \times \Phi 42 \times \Phi 50$	10
138	Barbell Bar Tube-Aluminium Cover	10
139	Stainless Outer Tube-200 $\Phi 49.5 \times 0.6 \times 200$	10
140	Hexagon Socket Button Head Screws M10*25	10
141	Double Shrapnel Nut $\Phi 23$ -M10 Double	10
142	Four Shrapnel Nut $\Phi 23$ -M11 Four	10
143	Ball Shape Chin Up Bar	1
144	Long Safety Catch-Right	1
145	Safety Catch-Outer Rubber 387	2
146	Long Safety Catch-Left	1
147	Swing Arm Fixing Seat	1
148	Swing Arm 1	1
149	Decorative Aluminum Cover $\Phi 11 \times \Phi 8 \times \Phi 28 \times \Phi 60$ 1	1
150	Footplate 1	1

# PARTS LIST

KEY NUMBER	DESCRIPTION OF PART	QUANTITY
151	Umbrella Head Pull Pin $\phi 12 \times M20 \times 40$	2
152	Short Safety Catch -Left	1
153	Roller Shaft $\phi 40 \times 88$	2
154	Bearing 6000	4
155	Safety Catch Rubber $\phi 190 \times 45 \times 7$	2
156	Countersunk Head Socket Head Screw M6*12	12
157	Hexagon Socket Button Head Screws M10*110	2
158	Short Safety Catch -Right	1
159	Move Hook	1
160	Hook Connect Shaft $\phi 15.8 \times 59 \times M10$	2
161	Powder Set $\phi 26 \times \phi 22 \times 16 \times 11$	4
162	Hook Cushion T8	4
163	Hexagon Socket Button Head Screws M8*40	8
164	Move Hook Plate T12	2
165	Move Hook-Right	1
166	Leg Press Adjust Frame	1
167	Pull Pin M18*12* $\phi 10$	1
168	Sponge $\phi 25 \times \phi 100 \times 175$	2
169	Sponge Inner Cap $\phi 65 \times \phi 25 \times 12$	2
170	Sponge Outer Cap $\phi 65 \times \phi 9 \times 12$	2
171	Hexagon Socket Button Head Screws M8*25	2
172	Double Shrapnel Nut $\phi 23 \times M8$ double	4
173	Oval Carabiner	
174	Left Stand Tube	1
175	Right Stand Tube	1

# PARTS LIST

KEY NUMBER	DESCRIPTION OF PART	QUANTITY
176	Sliding Sleeve	2
177	Counterweight Block Pulley Frame	2
178	Chin Tube	2
179	Hexagon Socket Screws Without Head M4*3	4
180	Stainless Tube -Right	1
181	Stainless Tube -Left	1
182	Hexagon Socket Set Screw M8*20	2
183	Sliding Sleeve-Right	1
184	Sliding Sleeve-Left	1
185	Chin Up Bar	1
186	Long Straight Bar	1
187	Short Straight Bar	1
188	Calf Block	1
189	A Bar Row Handle	1
190	Lat Pulldown Bar	1
191	Close Grip Triangle	1
192	Tricep V Bar	1
193	Metal Handle	2
194	Carabiner	7
195	Multi-Grip Lat Pulldown Bar	1
196	Nylon Handle	2
197	Right Barbell Rod Mounting Plate T5	1
198	Left Barbell Rod Mounting Plate T5	1
199	Chain	4
200	Tricep Rope	1

# PARTS LIST

KEY NUMBER	DESCRIPTION OF PART	QUANTITY
201	Swing Arm Fixing Seat	1
202	Thread Positioning Pin $\phi 25 \times 102.5$	1
203	Low Row Plate Assembly	1
204	Square Tube Inner Plug $60 \times 60 \times 2$	2
205	Hexagon Socket Button Head Screws M12*25	1
206	Hexagon Socket Button Head Screws M8*16	4
207	Inner Shaft $\phi 25 \times 67$ -M10	1
208	Low Row Foot Plate	1
209	Bearing 6005	1
210	Thrust Ball Bearing 53205	1
211	Flying Rings	2
212	Washer And Nut	1
213	Swing Arm	2
214	Spring Washer $\phi 8$	3
215	Locating Pin Knob Plate T8	1
216	Pedal Fixed Welds	1
217	Square Tube Inner Plug $50 \times 50 \times 2$	1
218	Umbrella Head Pull Pin $\phi 12 \times M20 \times 75$	1
219	Powder Set $\phi 50 \times \phi 47 \times \phi 25 \times 15$	2
220	Big Flat Washer $\phi 8$	1
221	Inner Lining Tube	1
222	Inner Shaft $\phi 17 \times 38$	2
223	Washer $\phi 33 \times \phi 12.5 \times T3$	2
224	Bearing 6001-2rs	2
225	Bearing Sleeve $\phi 33 \times \phi 22$	2

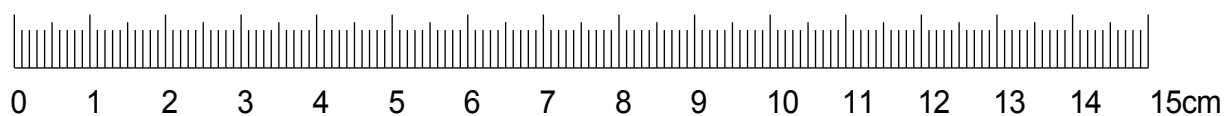

# PARTS LIST

KEY NUMBER	DESCRIPTION OF PART	QUANTITY
226	T Shape Pin $\Phi 9.4 \times \Phi 6.3$	2
227	T Shape Lining Sleeve $\Phi 13 \times \Phi 9.45$	4
228	U Shape Fastener	2
229	Catch 5	2
230	Foot Pad Welds	1
231	Ev Stickers 205*55*2	2
232	Puller Handle	1
233	Big Pull Elbow $\Phi 25 \times 2$	1
234	Hand Handle Outer Baffle Ring $\Phi 31.5 \times \Phi 25.5$	2
235	Pull The Hanging Piece T6	1
236	Pull The Baffle Ring $\Phi 39 \times \Phi 26 \times 12$	2
237	Hand Handle Inner Baffle Ring $\Phi 33 \times \Phi 26 \times 10.5$	2
238	Handle Cover $\Phi 25 \times 480$	2
239	Hexagon Socket Set Screws With Concave End M6*6	6





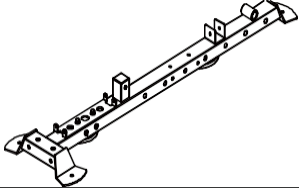

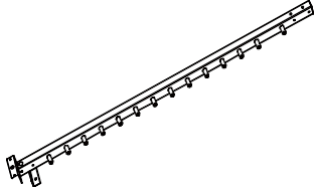
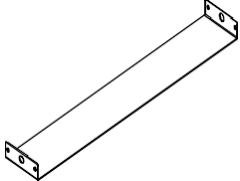
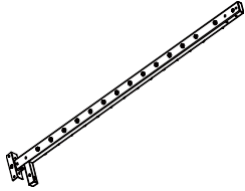
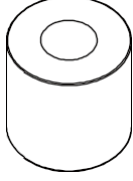
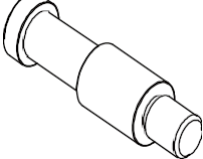
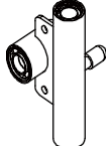



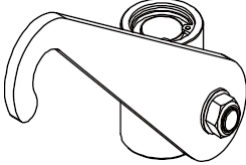
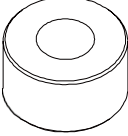
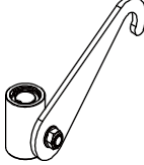

# PARTS LIST

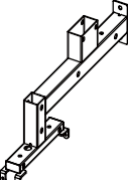
NUMBER	DESCRIPTION OF PART	QTY	PARTS DRAWING
1	Ground Tube	2	
2	Front Guide Rod	6	
3	Left Stand Tube	1	
4	Connect Support Tube	1	
5	Right Stand Tube	1	
6	Crush Pad	4	
11	Hang Shaft	16	
13	Silding Sleeve Welding	2	

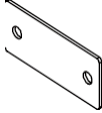
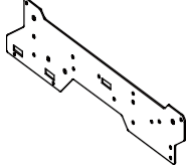
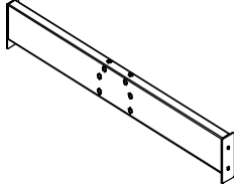

# PARTS LIST

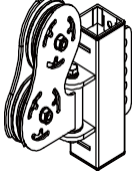
NUMBER	DESCRIPTION OF PART	QTY	PARTS DRAWING
14	Barbell Rod	1	
15	Safety Hook Right	1	
16	Rubber Pad	4	
17	Safety Hook Left	1	
19	Weight Stack	2	
21	Magnetic Pull Pin	2	
24	Counterweight Block Pulley Frame	2	
25	Chin Bar	2	

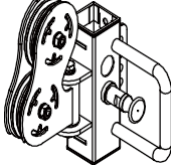
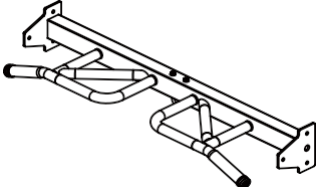
# PARTS LIST

NUMBER	DESCRIPTION OF PART	QTY	PARTS DRAWING
26	Connecting Piece - Two Holes	2	
27	Up Decoate Plate	4	
28	Back Chin Up Bar	1	
31	Stainless Steel Guide Rod Left	1	
32	The Birds Sliding Sleeve Left	1	
33	Stainless Steel Guide Rod Right	1	
34	The Birds Sliding Sleeve Right	1	
35	Across Connected Plate	1	

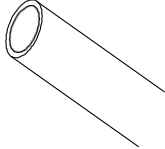
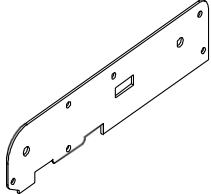
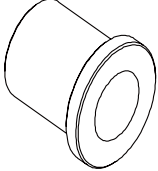
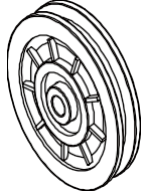
# PARTS LIST

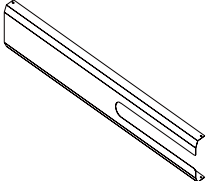
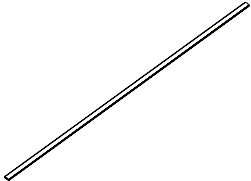
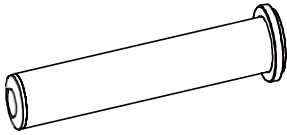
NUMBER	DESCRIPTION OF PART	QTY	PARTS DRAWING
39	Decorative Plate Support Tube	6	
40	Decorative Plate Of Bottom Beam	4	
41	Powder Set	24	
42	Pulley	12	
44	Wire Rope-Nose	2	
45	Back Shield	4	
46	Shield Of Edge	4	
49	Barbell Rod Sleeve	2	

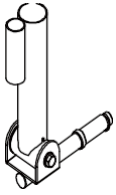
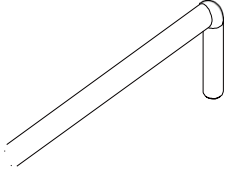
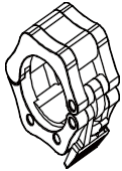
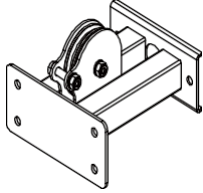
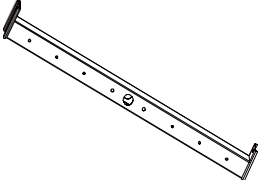
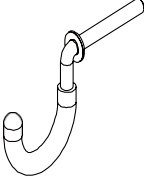
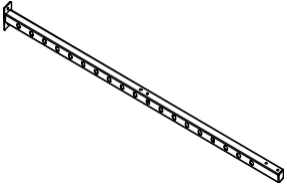
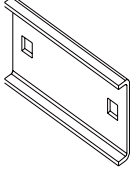

# PARTS LIST

NUMBER	DESCRIPTION OF PART	QTY	PARTS DRAWING
50	Core Trainer with Rotation Holder	1	
51	Band Pegs	4	
52	Olympic Lock Collar	2	
54	Back Up Connection Tube	1	
55	Pull Up The Beam Welder	1	
56	Hook	6	
57	Rear Column	2	
58	Concave Plate	2	

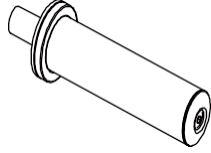
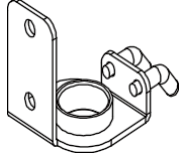
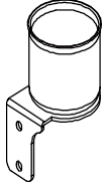
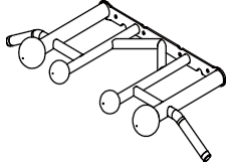
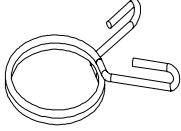
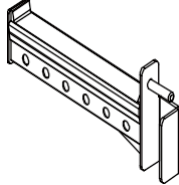
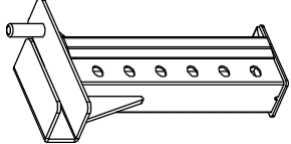
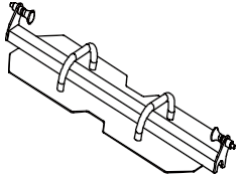
# PARTS LIST

NUMBER	DESCRIPTION OF PART	QTY	PARTS DRAWING
60	Weight Plate Sleeve	10	
61	Barbell Holder	1	
62	Small Handle Fix Tube	1	
63	Globe Chin Up Bar	1	
64	Spring Collar	10	
65	Right Front Safety	1	
66	Left Front Safety	1	
67	Leg Press Plate	1	

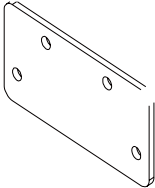
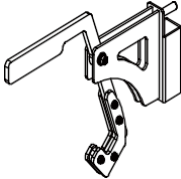
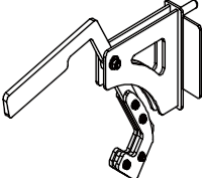
# PARTS LIST

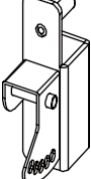
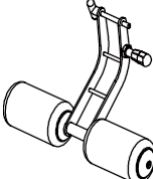
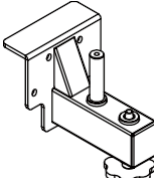



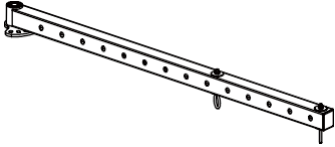
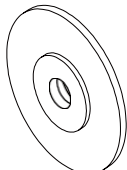
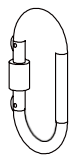
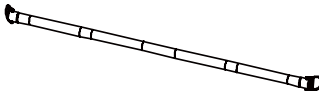
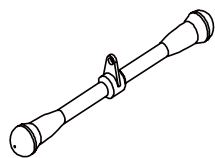
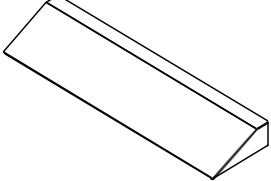
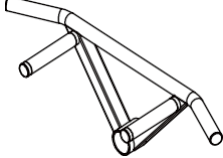
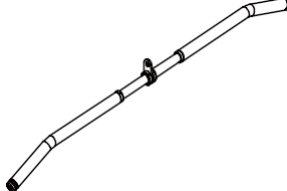

NUMBER	DESCRIPTION OF PART	QTY	PARTS DRAWING
68	Swing Arm Fixed Reinforcement Plate	1	
69	Left Mono Lift	1	
70	Right Mono Lift	1	
71	Left Roller J-Hook	1	
72	Right Roller J-Hook	1	
74	Knee Anchor J-Hook	1	
75	Lat Pulldown Knee Anchor	1	
147	Swing Arm Fixing Seat	1	

# PARTS LIST

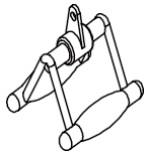
NUMBER	DESCRIPTION OF PART	QTY	PARTS DRAWING
148	Swing Arm	1	
149	Decorative Aluminium Cover	1	
173	Oval Carabiner	1	
186	Long Straight Bar	1	
187	Short Straight Bar	1	
188	Calf Block	1	
189	A Bar Row Handle	1	
190	Lat Pulldown Bar	1	

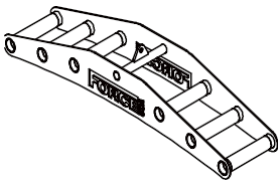

# PARTS LIST

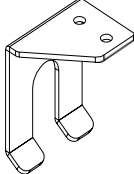
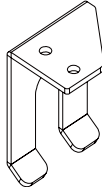
NUMBER	DESCRIPTION OF PART	QTY	PARTS DRAWING
191	Close Grip Triangle	1	
192	Tricep V Bar	1	
193	Metal Handle	2	
194	Carabiner	7	
195	Multi Grip Lat Pulldown Bar	1	
196	Nylon Handle	2	
197	Right Barbell Rod Mounting Plate	1	
198	Left Barbell Rod Mounting Plate	1	

# PARTS LIST

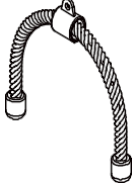
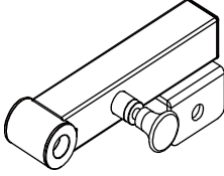
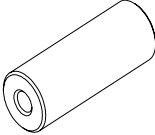
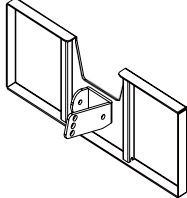
NUMBER	DESCRIPTION OF PART	QTY	PARTS DRAWING
199	Chain	4	
200	Tricep Rope	1	
203	Low Row Plate Assembly	1	
207	Inner Shaft	1	
208	Low Row Foot Plate	1	

# ASSEMBLY STEP 1 EXPLOSION DRAWING

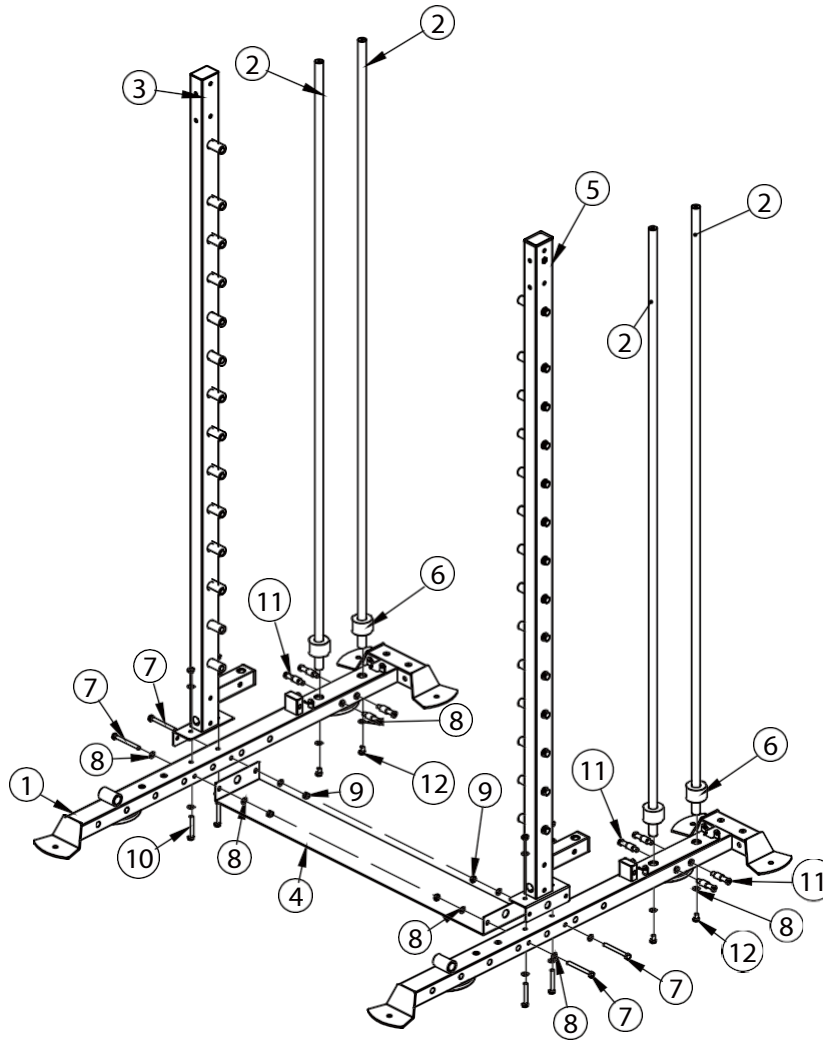

KEY NUMBER	DESCRIPTION OF PART	QUANTITY
1	Ground Tube	2
2	Front Guide Rod $\phi 25*2050$	4
3	Left Stand Tube	1
4	Connect Support Tube T3	1
5	Right Stand Tube	1
6	Crush Pad $\phi 60*27*42$	3
7	Hexagon Bolt M10*95	3
8	Flat Washer(Gb) $\phi 10$	20
9	Lock Nut M10	8
10	Hexagon Bolt M10*70	4
11	Hang Shaft $\phi 17.8*17$ -M12	8
12	Hexagon Bolt M10*16	4

# ASSEMBLY DRAWING

GROUND TUBE QTY: 2PCS/SET

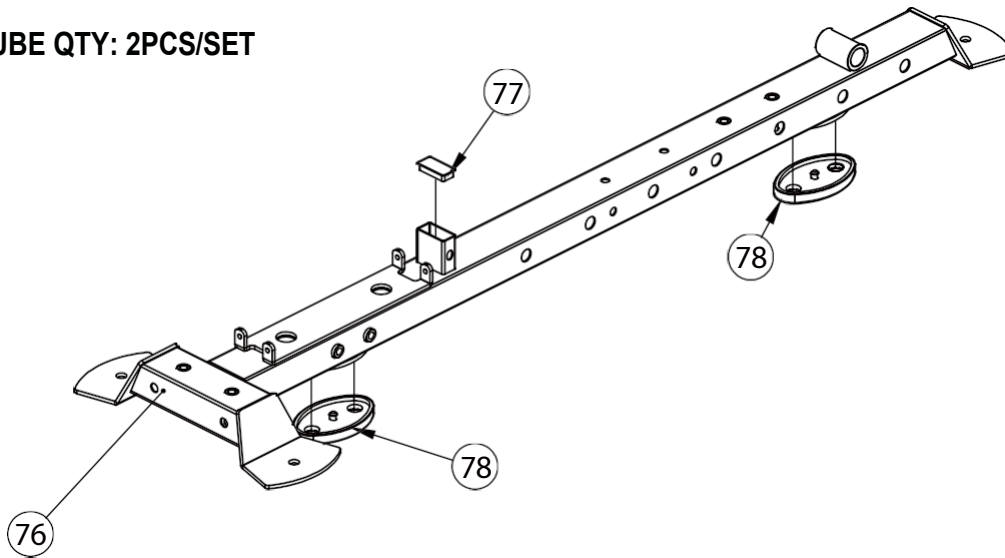

KEY NUMBER	DESCRIPTION OF PART	QUANTITY
73	Ground Pipe Welds	1
77	Square Tube Plug 25*50*1.5	1
78	Oval Ring 131*80	2

LEFT STAND TUBE QTY: 1PCS/SET

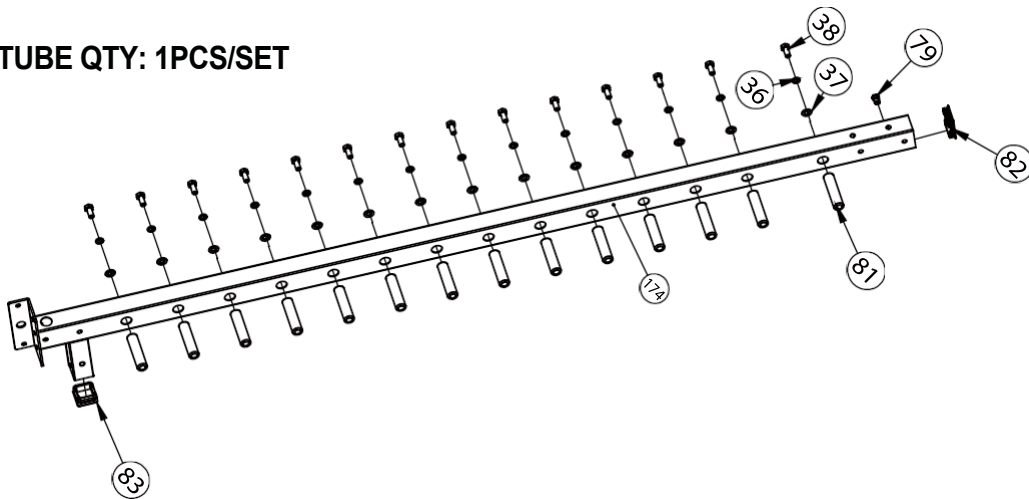

KEY NUMBER	DESCRIPTION OF PART	QUANTITY
81	Hang Shaft $\phi 25 \times M12 \times 98$	14
82	50*70*1.5 Square Tube Plug 50*70*1.5	1
83	50 Square Tube Plug 50*50*2	1
79	Countersunk Hexagon Rivet Nuts M10	1
38	Hexagon Bolt M12*25	14

# ASSEMBLY DRAWING

RIGHT STAND TUBE QTY: 1PCS/SET

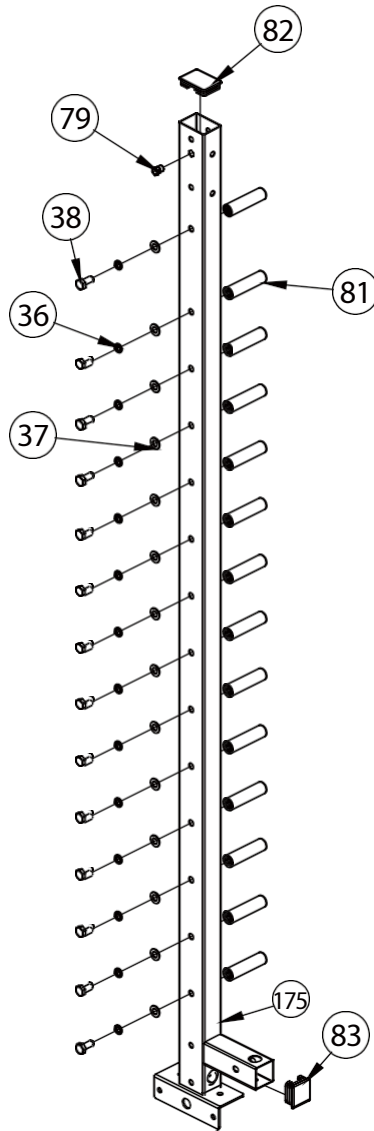

KEY NUMBER	DESCRIPTION OF PART	QUANTITY
81	Hang Shaft $\phi 25 \times M12 \times 98$	14
82	50*70*1.5 Square Tube Plug 50*70*1.5	1
83	50 Square Tube Plug 50*50*2	1
79	Countersunk Hexagon Rivet Nuts M10	1
38	Hexagon Bolt M12*25	14
36	Spring Washer $\phi 12$	14
37	Flat Washer $\phi 12$	14
175	Right Stand Tube	1

# ASSEMBLY STEP 1 INSTRUCTION DRAWING

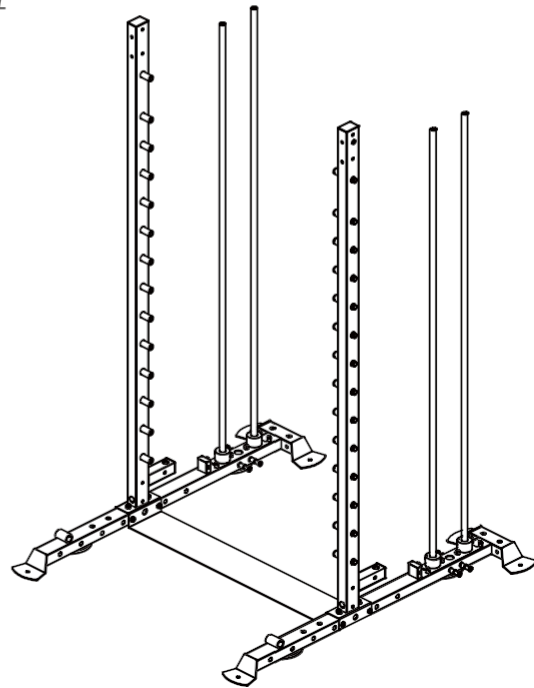
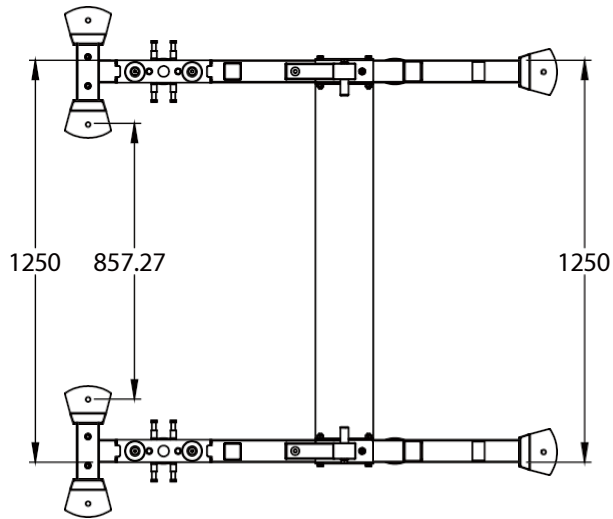

1. Use M10\*16 hexagon bolt (12) and flat washer(GB) (8) to assemble front guide rod (2) in ground tube(1),Mount the crush pad(6) on the front guide rod (2).
2. Assemble the hang shaft(11) on the ground tube (1).
3. Use M10\*70 hexagon bolt(10) and flat washer(GB) to assemble left stand tube (3) and right stand tube(5) respectively on the ground tube (1).
4. Use M10\*95 hexagon bolt (7), flat washer(GB) (8), M10 lock nut (9) to connect support tube (4) Assembled on ground tube(1).

**Attention:** Please pay attention to the front and back dimensions when installing.

## ASSEMBLY STEP 2 EXPLOSION DRAWING

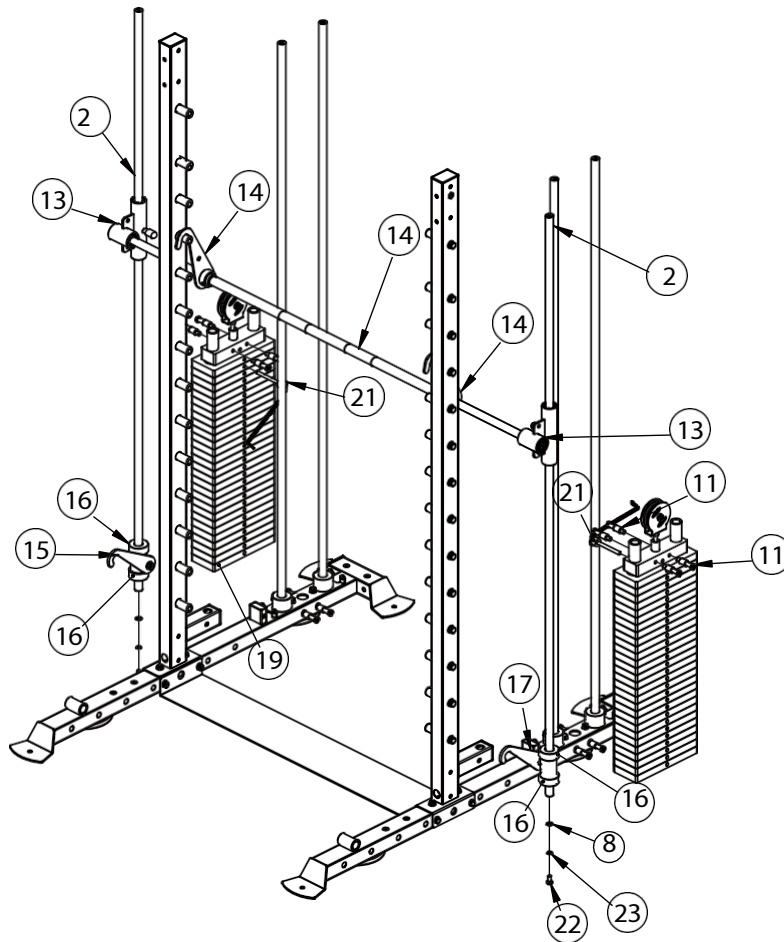

KEY NUMBER	DESCRIPTION OF PART	QUANTITY
13	Silding Sleeve Welding	2
14	Barbell Rod	1
15	Safety Hook Right	1
16	Rubber Pad $\phi 60 * \phi 26 * 25$	4
17	Safety Hook Left	1
2	Front Guide Rod $\phi 25 * 2050$	2
19	Weight Stack	2
11	Hang Shaft $\phi 17.8 * 17 - M12$	8
21	Magnetic Pull Pin $\phi 10 * 100$	2
22	Hexagon Bolt M10*20	2
8	Flat Washer(Gb) $\phi 10$	2
23	Spring Gasket $\phi 10$	2
24	Counterweight Block Pulley Frame	2

# ASSEMBLY DRAWING

SILDING SLEEVE WELDING QTY: 2PCS/SET

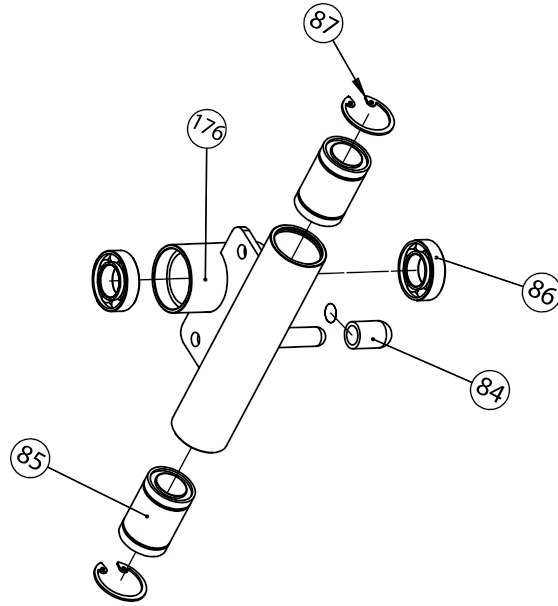

KEY NUMBER	DESCRIPTION OF PART	QUANTITY
84	Rubber Cover $\phi 21 \times 35$	1
85	Lining Bearing $\phi 40 \times \phi 25 \times 58$	2
86	Bearing 6005	2
87	Spring Catch Collar $\phi 40$	2
176	Sliding Sleeve	1

BARBELL ROD QTY: 1PCS/SET

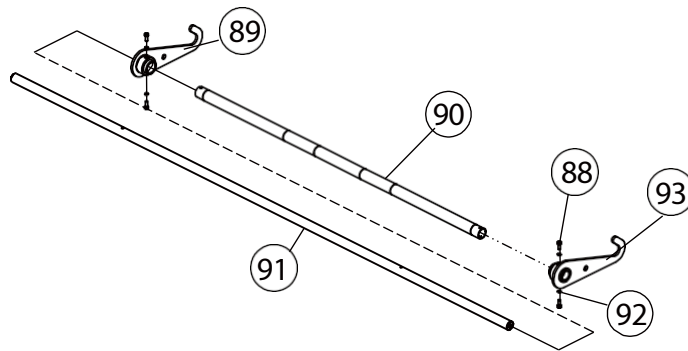

KEY NUMBER	DESCRIPTION OF PART	QUANTITY
90	Barbell Aluminum Rod $\phi 30 \times \phi 25.1 \times 1056$	1
88	Hexagon Socket Cap Screws M6*16	4
89	Hook Right	1
91	Barbell Inner Rod $\phi 25 \times 1857$	1
92	Spring Washer $\phi 6$	4
93	Hook Left	1



# ASSEMBLY DRAWING

SAFETY HOOK RIGHT QTY: 1PCS/SET

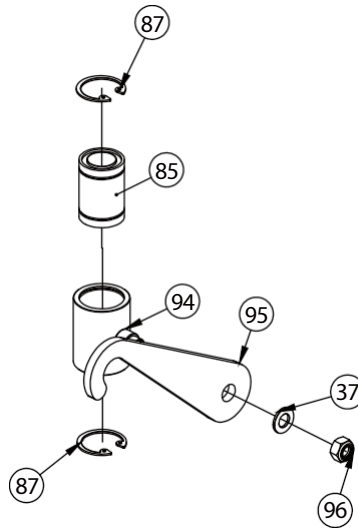

KEY NUMBER	DESCRIPTION OF PART	QUANTITY
90	Barbell Aluminum Rod $\phi 30 \times \phi 25.1 \times 1056$	1
88	Hexagon Socket Cap Screws M6*16	4
89	Hook Right	1
91	Barbell Inner Rod $\phi 25 \times 1857$	1
92	Spring Washer $\phi 6$	4
93	Hook Left	1

SAFETY HOOK LEFT QTY: 1PCS/SET

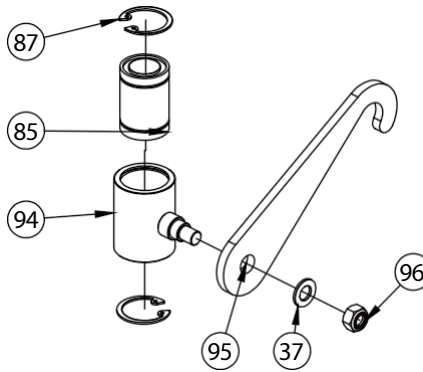

KEY NUMBER	DESCRIPTION OF PART	QUANTITY
85	Lining Bearing $\phi 40 \times \phi 25 \times 58$	1
87	Spring Catch Collar $\phi 40$	2
94	Safety Hook Welding	1
95	Safety Hook T8	1
96	Lock Nut M12	1
37	Flat Washer $\phi 12$	1

# ASSEMBLY DRAWING

COUNTERWEIGHT BLOCK PULLEY FRAME QTY: 2PCS/SET

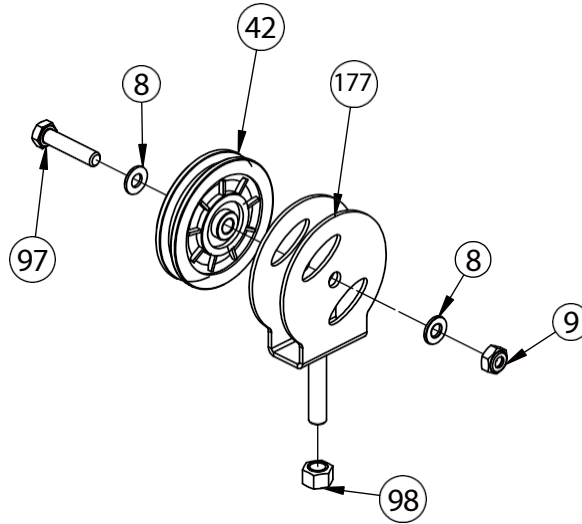

KEY NUMBER	DESCRIPTION OF PART	QUANTITY
42	Pulley $\phi 92$	1
97	Hexagon Bolt M10*45	1
9	Lock Nut M10	1
8	Flat Washer(Gb) $\phi 10$	2
98	Hexagon Nut M12	1

## ASSEMBLY STEP 2 INSTRUCTION DRAWING

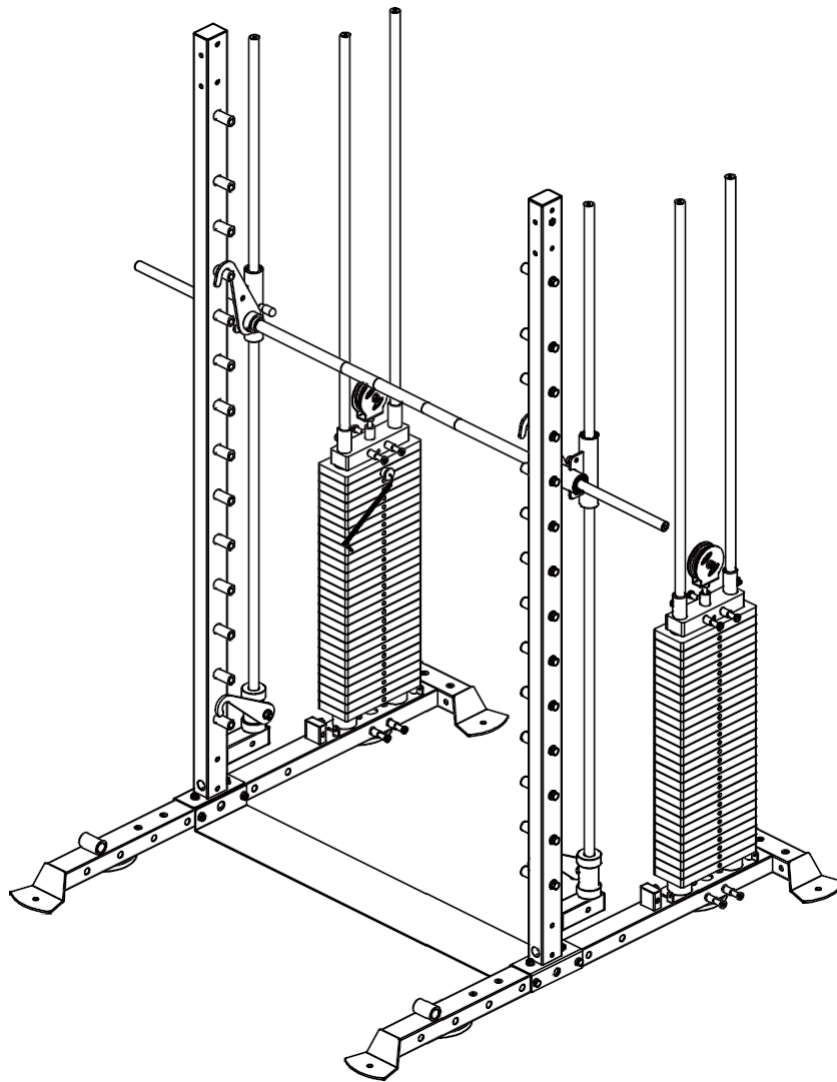

1. Assemble rubber pad (16), safety hook right (15) and sliding sleeve welding (13) before front guide rod (2).
2. Assemble rubber pad (16), safety hook left(17) and sliding sleeve welding (13) before front guide rod (2).
3. Assemble the barbell rod(14) on the sliding sleeve welding(13).
4. Use M10\*20 hexagon bolt(22),  $\phi$ 10 flat washer (8),  $\phi$ 10 spring gasket(23) to assemble the front guide rod (2) is mounted on the main body.
5. As shown in the figure, assemble weight stack(19) on the front guide rod (2).
6. Insert magnetic pull pin(21) into cast iron weight stack(19).
7. Assemble the counterweight block pulley frame(24) of the counterweight block to the cast iron weight stack(19).

# ASSEMBLY STEP 3 EXPLOSION DRAWING

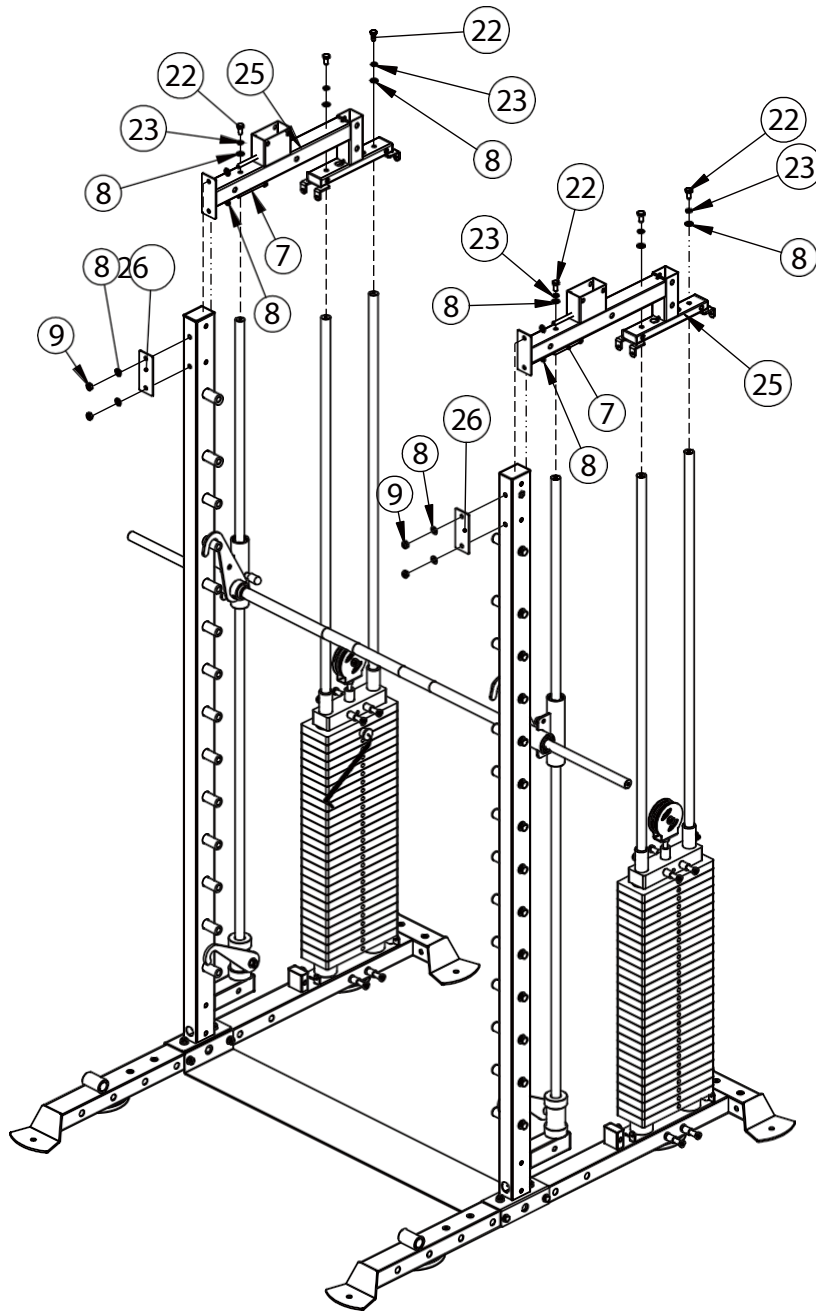

KEY NUMBER	DESCRIPTION OF PART	QUANTITY
25	Chin Bar	2
26	Connecting Piece - Two Holes T3.0*50*120	2
22	Hexagon Bolt M10*20	6
23	Spring Gasket φ10	6
8	Flat Washer(Gb) φ10	14
7	Hexagon Bolt M10*95	4
9	Lock Nut M10	4

# ASSEMBLY DRAWING

CHIN BAR QTY: 2PCS/SET

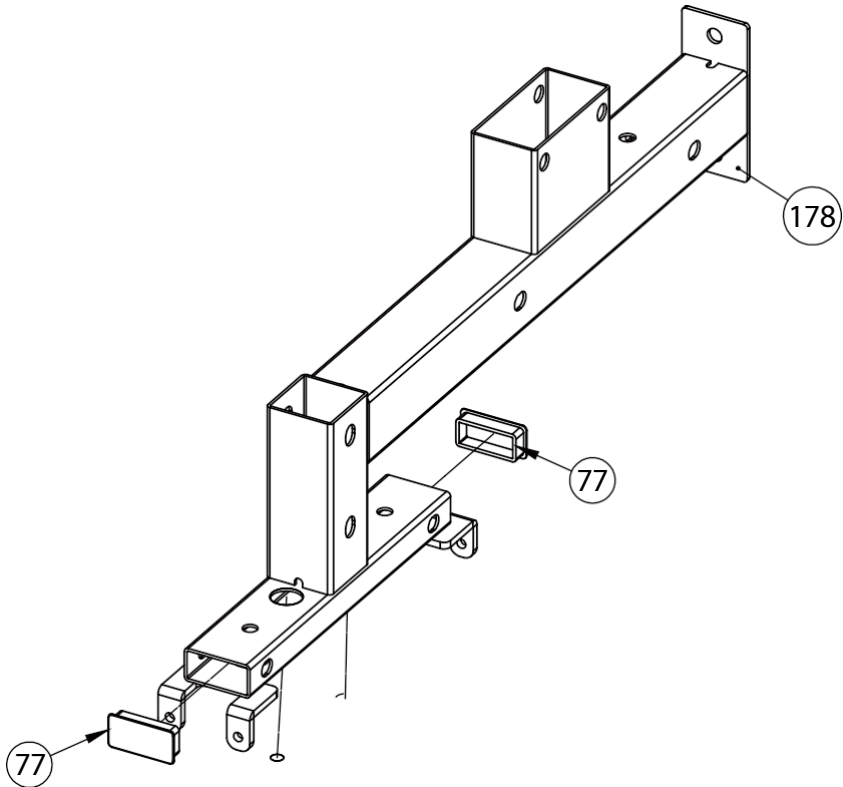

KEY NUMBER	DESCRIPTION OF PART	QUANTITY
178	Chin Tube	1
77	Square Tube Inner Plug 25*50*2	2

## ASSEMBLY STEP 3 INSTRUCTION DRAWING

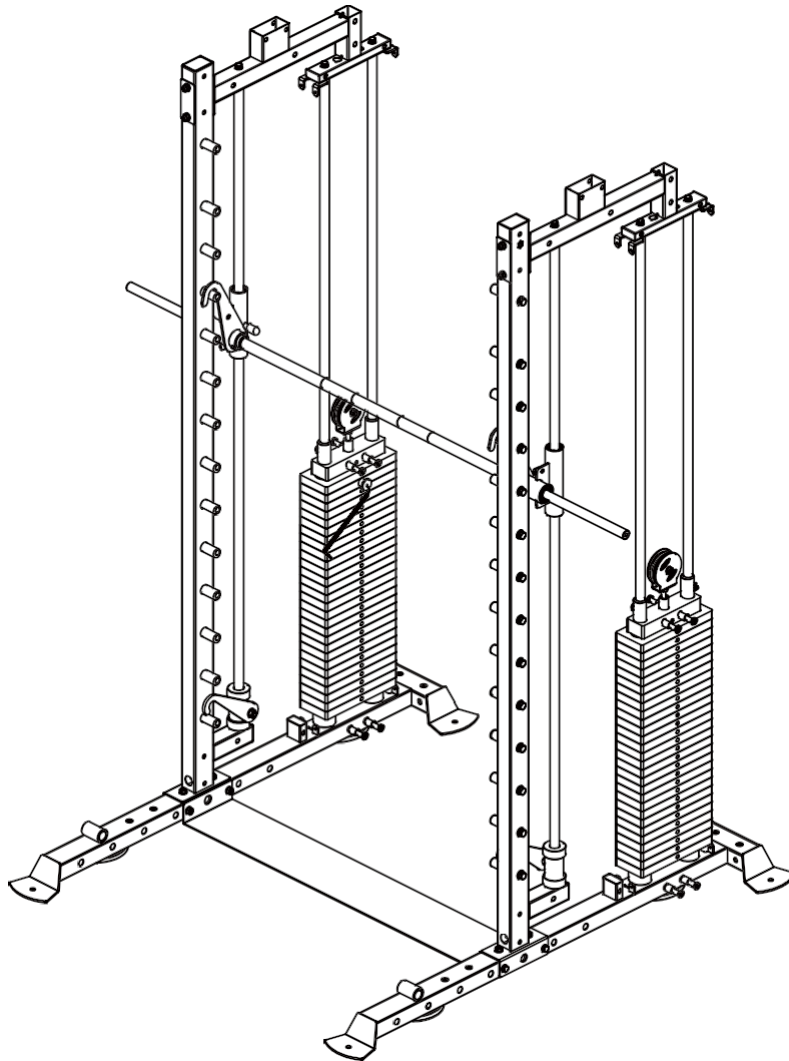

1. As shown in the figure, Use M10\*20 hexagon bolt (22), flat washer(GB) (8), spring gasket(23), mount chin bar (25) to front guide rod (2).
2. Use M10\*95 hexagon bolt (7), flat washer(GB) (8), M10 lock nut (9) to connecting piece - two holes and chin bar(25) assembly to left stand tube(3).
3. The left and right assembling methods are the same.

# ASSEMBLY STEP 4 EXPLOSION DRAWING

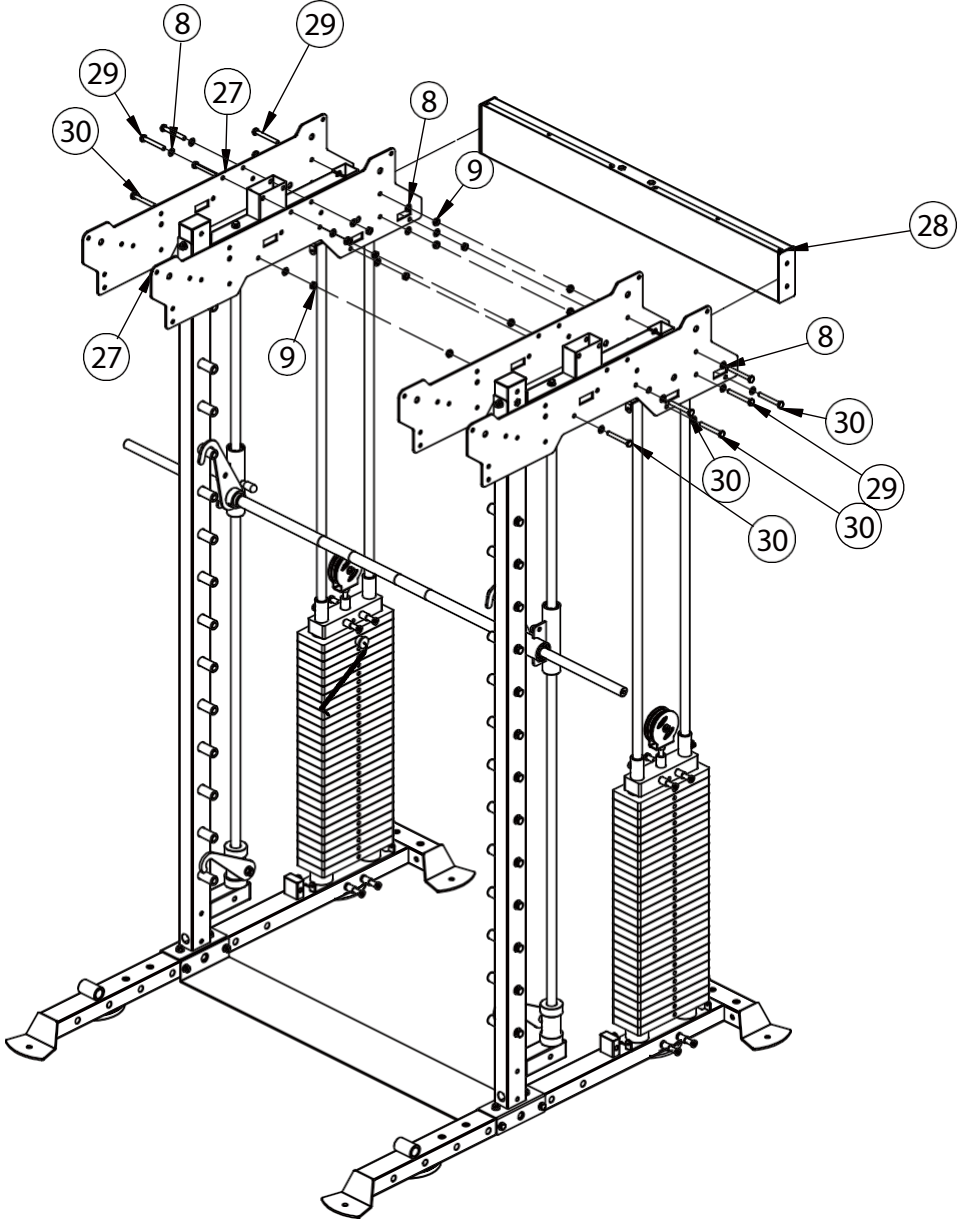

KEY NUMBER	DESCRIPTION OF PART	QUANTITY
27	Up Decoate Plate T5	4
28	Back Chin Up Bar	1
29	Hexagon Bolt M10*80	4
8	Flat Washer(Gb) φ10	28
9	Lock Nut M10	14
30	Hexagon Bolt M10*75	10

# ASSEMBLY DRAWING

BACK CHIN UP BAR QTY: 1PCS/SET

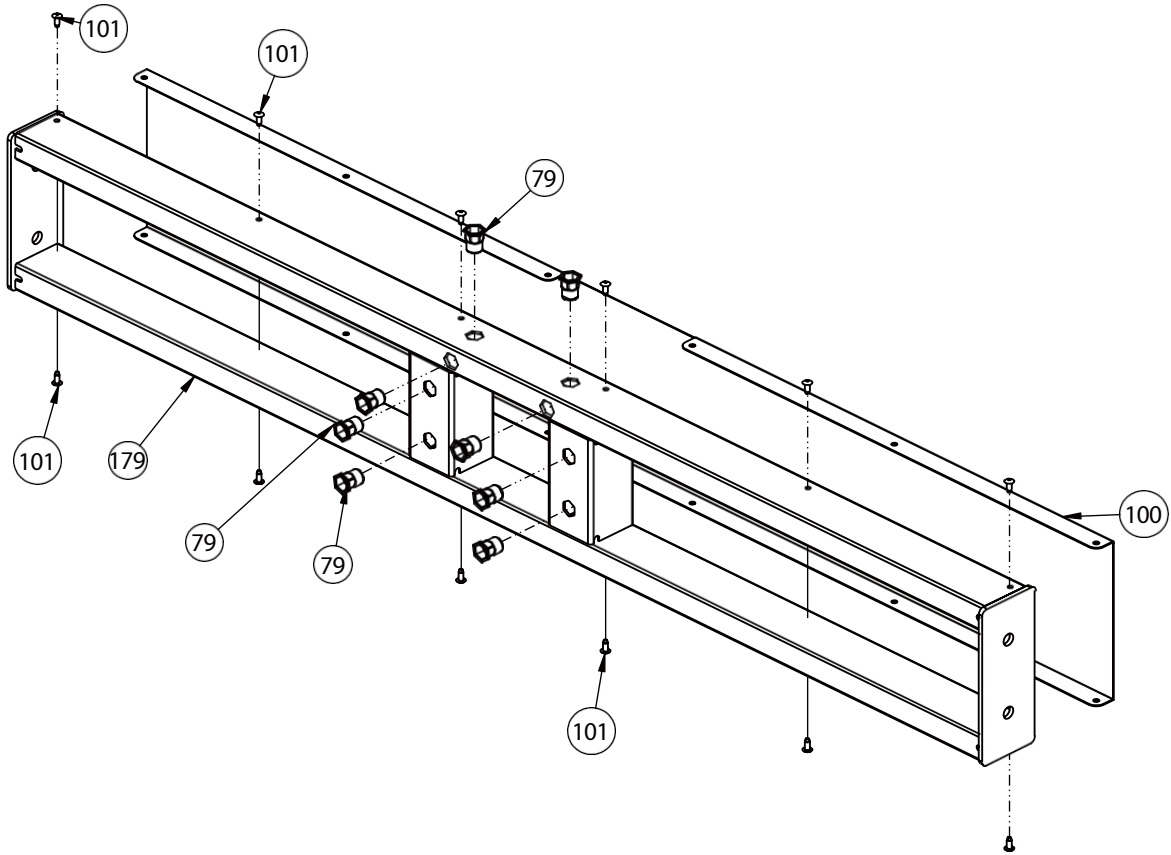

KEY NUMBER	DESCRIPTION OF PART	QUANTITY
100	Decorate Plate T1	1
79	Countersunk Hexagon Rivet Nuts M10	8
101	Mushroom Head Break Mandrel Blind Rivets 4*8	12
179	Hexagon Socket Screws Without Head	1



## ASSEMBLY STEP 4 INSTRUCTION DRAWING

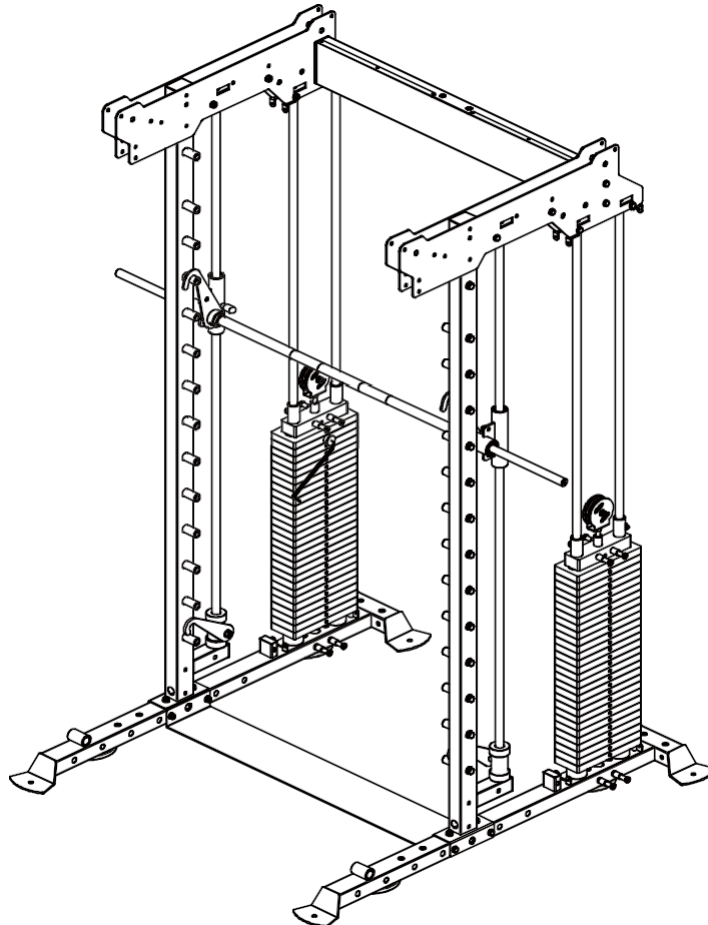

1. Use M10\*75 hexagon bolt (30),  $\phi 10$  flat washers (8), M10 lock nuts (9) to decorate the Up decoate plate (27) is assembled on both sides of the chin up bar (28).
2. Use M10\*80 hexagon bolt(29),  $\phi 10$  flat washer (8), M10 lock nut (9) to mount the chin up bar (28) mount on the Up decoate plate (27).

# ASSEMBLY STEP 5 EXPLOSION DRAWING

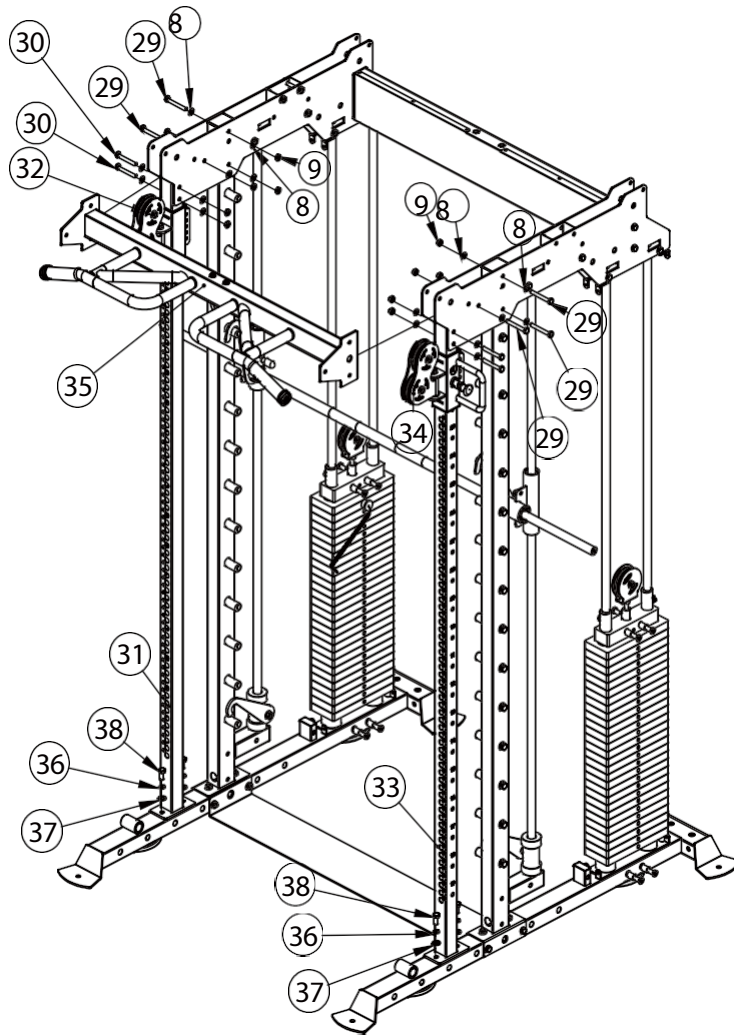

KEY NUMBER	DESCRIPTION OF PART	QUANTITY
31	Stainless Steel Guide Rod Left	1
32	The Birds Sliding Sleeve Right	1
33	Stainless Steel Guide Rod Right	1
34	The Birds Sliding Sleeve Left	1
35	Across Connected Plate	1
29	Hexagon Bolt M10*80	6
8	Flat Washer(Gb) $\phi$ 10	20
9	Lock Nut M10	10
30	Hexagon Bolt M10*75	4
36	Spring Washer $\phi$ 12	4
37	Flat Washer $\phi$ 12	4
38	Hexagon Bolt M12*25	4

# ASSEMBLY DRAWING

STAINLESS STEEL GUIDE ROD RIGHT QTY: 1PCS/SET

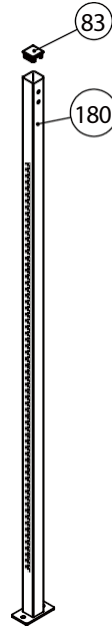

KEY NUMBER	DESCRIPTION OF PART	QUANTITY
180	Stainless Tube -Right	1
83	Square Tube Plug 50*50*2	1

STAINLESS STEEL GUIDE ROD LEFT QTY: 1PCS/SET

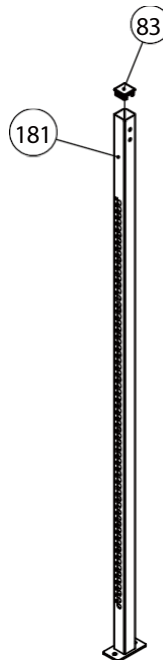

KEY NUMBER	DESCRIPTION OF PART	QUANTITY
181	Lining Bearing $\phi 40 * \phi 25 * 58$	1
83	Spring Catch Collar $\phi 40$	2

# ASSEMBLY DRAWING

THE BIRDS SLIDING SLEEVE RIGHT QTY: 1PCS/SET

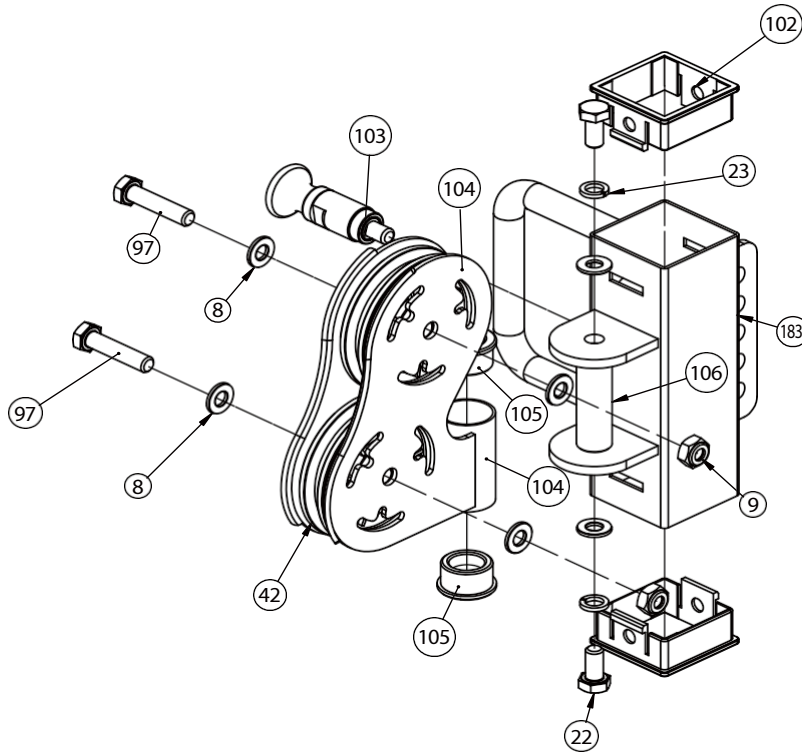

KEY NUMBER	DESCRIPTION OF PART	QUANTITY
183	Sliding Sleeve-Right	1
102	Bush Bearing 50-60	2
103	Aluminium Spring Pin M20*1.5-φ10	1
8	Flat Washer(Gb) φ10	6
97	Hexagon Bolt M10*45	2
9	Lock Nut M10	2
42	Pulley φ92	2
106	Inner Shaft φ20*67	1
104	Pulley Rotation Cover	1
105	Powder Set φ33*φ29*φ20*18	2
22	Hexagon Bolt M10*20	2
23	Spring Gasket φ10	2

# ASSEMBLY DRAWING

THE BIRDS SLIDING SLEEVE LEFT QTY: 1PCS/SET

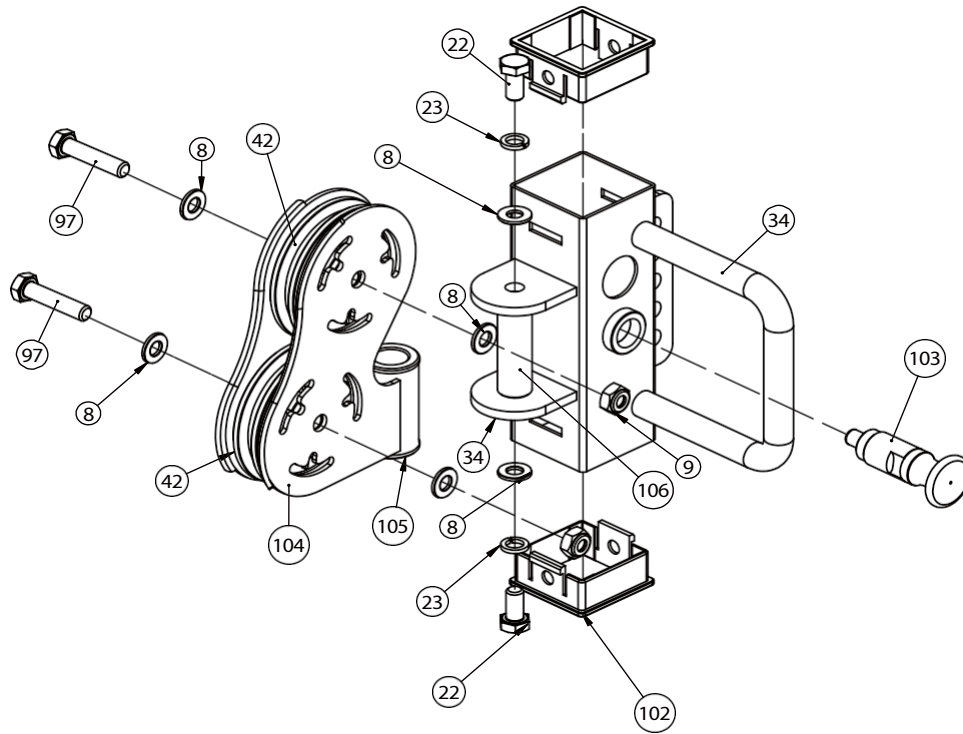

KEY NUMBER	DESCRIPTION OF PART	QUANTITY
184	Sliding Sleeve-Left	1
102	Bush Bearing 50-60	2
103	Aluminum Spring Pin M20*1.5-φ10	1
8	Flat Washer(Gb) φ10	6
97	Hexagon Bolt M10*45	2
9	Lock Nut M10	2
104	Pulley Rotation Cover	1
42	Pulley φ92	2
105	Powder Set φ33*φ29*φ20*18	2
106	Inner Shaft φ20*67	1
22	Hexagon Bolt M10*20	2
23	Spring Gasket φ10	2

# ASSEMBLY DRAWING

ACROSS CONNECTED PLATE QTY: 1PCS/SET

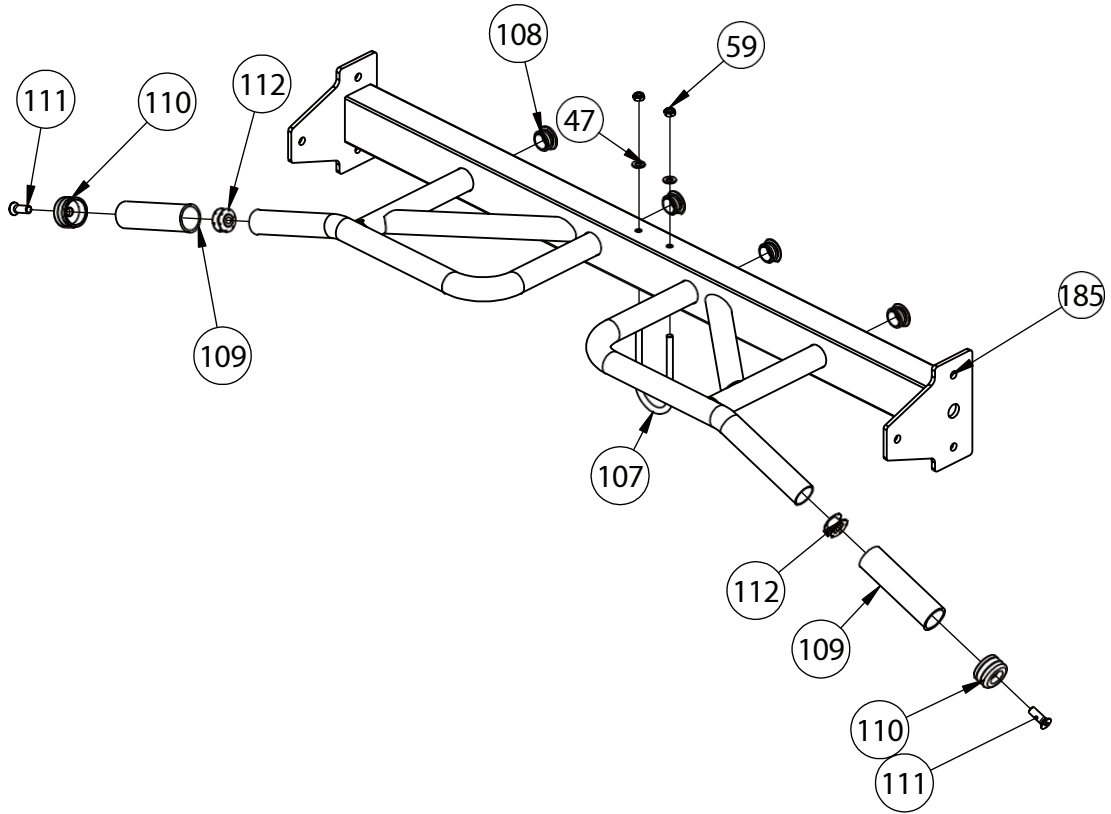

KEY NUMBER	DESCRIPTION OF PART	QUANTITY
107	Hanging Ring Weldment	1
47	Flat Washer $\phi 8$	2
59	Lock Nut M8	2
108	Circle Tube Plug $\phi 32 \times 1.5$	4
109	Handle Cover $\phi 38 \times \phi 32 \times 130$	2
110	Outer Catch Collar $\phi 38 \times 32 \times 25$	2
111	Hexagon Socket Set Screw M10*25	2
112	Double Shrapnel Nut $\phi 29.3$ -M10	2
185	Chin Up Bar	1

## ASSEMBLY STEP 5 INSTRUCTION DRAWING

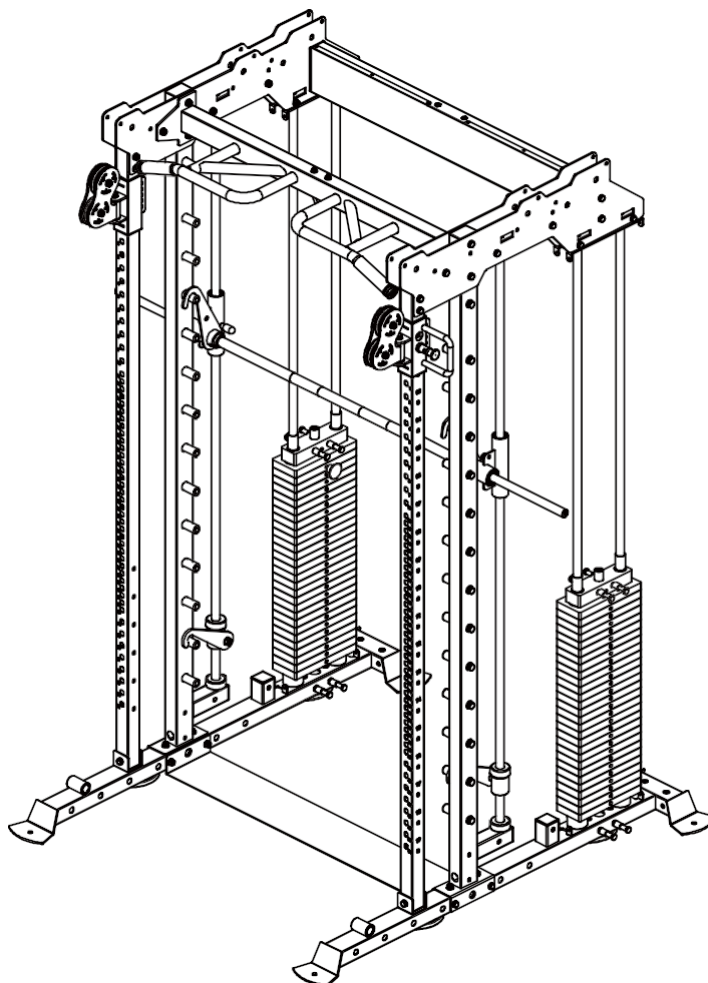

1. Assemble the birds sliding sleeve right(32) into the stainless steel guide rod right(33).
2. Assemble the birds sliding sleeve left(34) into the stainless steel guide rod left(31).
3. Use M12\*25 hexagon bolts (38),  $\phi 12$  flat washer (37),  $\phi 12$  spring gasket (36) as shown in the picture stainless steel guide rod right(33) is mounted on the main body. The left and right assembly mode is the same.
4. Use M10\*75 hexagon bolts (30),  $\phi 10$  flat washer (8), M10 lock nut (9) to install the stainless steel guide rod right (33) is assembled on the decorative board on the main body, and the left and right assembly methods are the same.
5. As shown in the picture, use M10\*80 hexagon bolts (29),  $\phi 10$  flat washer (8), M10 lock nut (9) to install across connected plate (35) is assembled on the main body.

# ASSEMBLY STEP 6 EXPLOSION DRAWING

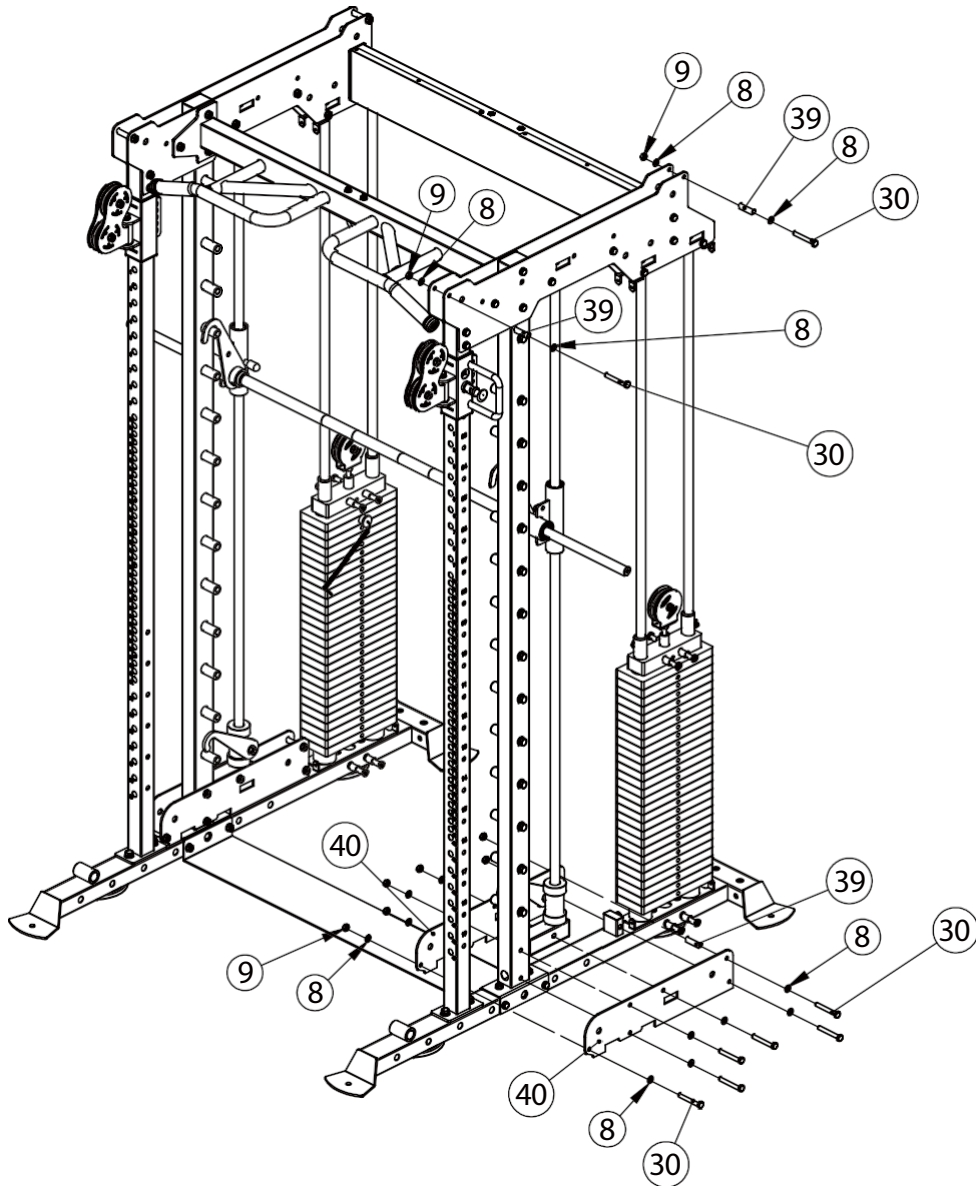

KEY NUMBER	DESCRIPTION OF PART	QUANTITY
39	Decorative Plate Support Tube $\phi 14 \times 1.5 \times 49$	6
30	Hexagon Bolt M10*75	16
8	Flat Washer(Gb) $\phi 10$	32
9	Lock Nut M10	16
40	Decorative Plate Of Bottom Beam T5	4



## ASSEMBLY STEP 6 INSTRUCTION DRAWING

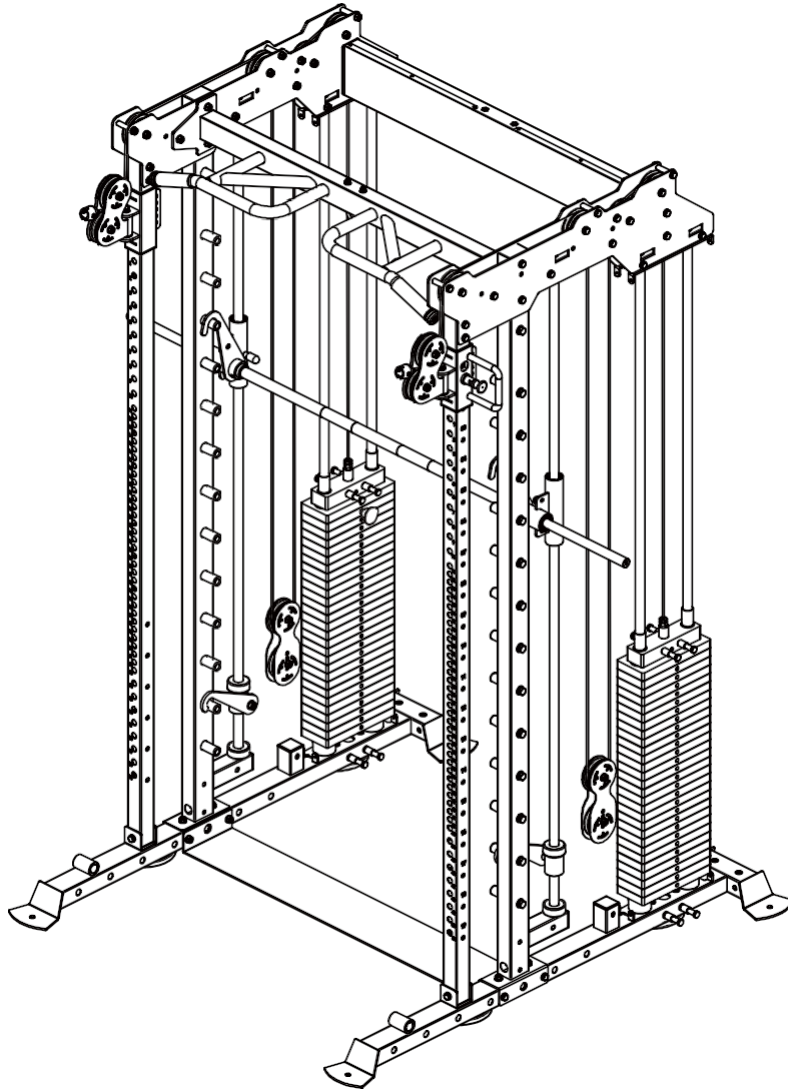

1. Assemble the decorative plate of 3070B bottom beam to the main body with M10×75 hexagon bolt (30),  $\phi 10$  flat washers (8), M10 lock nut (9) to fix it to the main body. The left and right assembly mode is the same.
2. As shown in the figure, install with M10\*75 hexagon bolt (30),  $\phi 10$  flat washer (8) and M10 lock nut (9) decorative plate support tube (39) is assembled to the main body. The left and right assembly mode is the same.

# ASSEMBLY STEP 7 EXPLOSION DRAWING

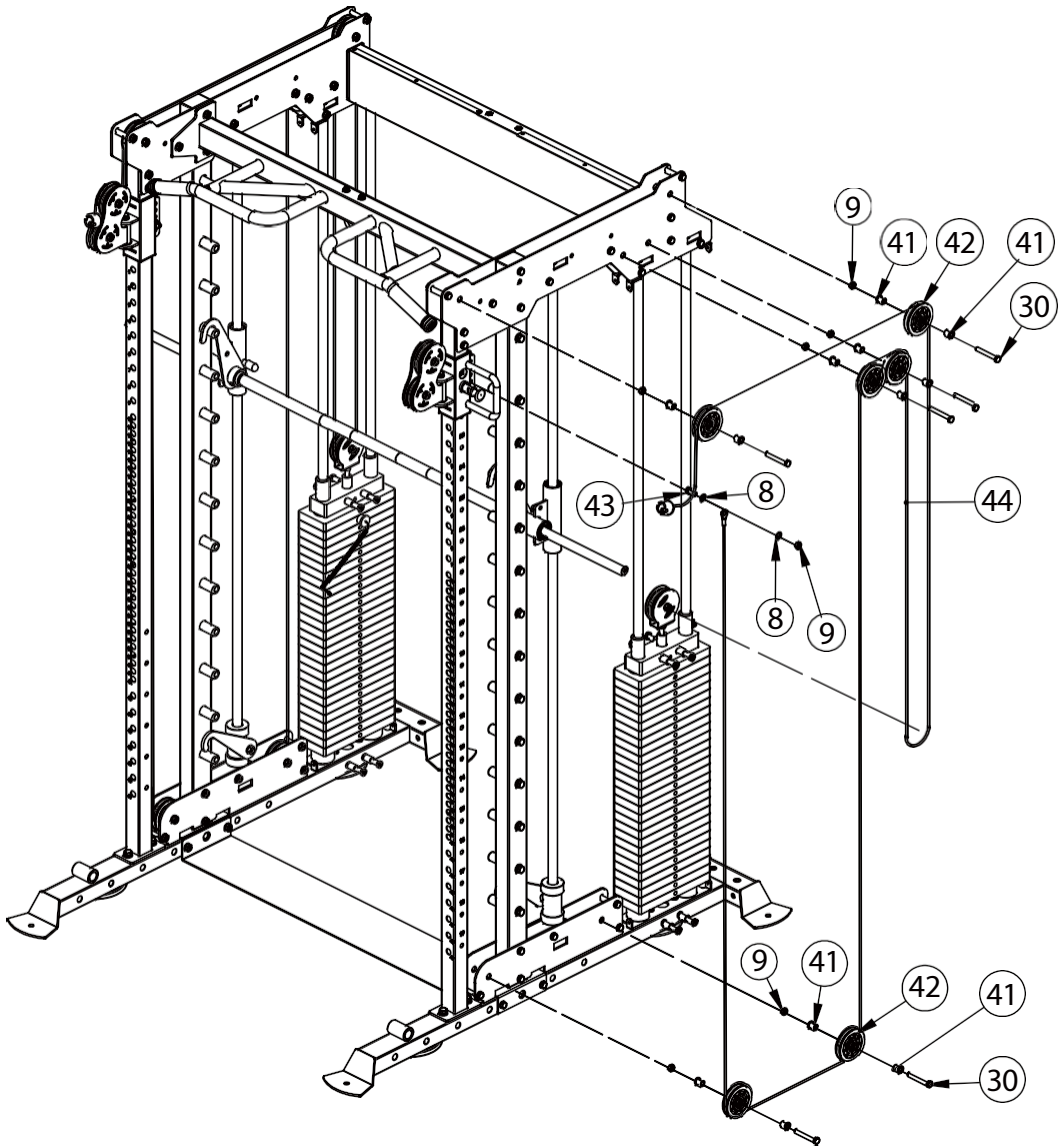

KEY NUMBER	DESCRIPTION OF PART	QUANTITY
30	Hexagon Bolt M10*75	12
9	Lock Nut M10	14
41	Powder Set $\phi 20 * \phi 16 * \phi 10.5 * 20.5$	24
42	Pulley $\phi 92$	12
43	Hexagon Bolt M10*25	2
8	Flat Washer(Gb) $\phi 10$	4
44	Wire Rope-Nose Nose $\phi 5 * 8330$	2

# ASSEMBLY DRAWING

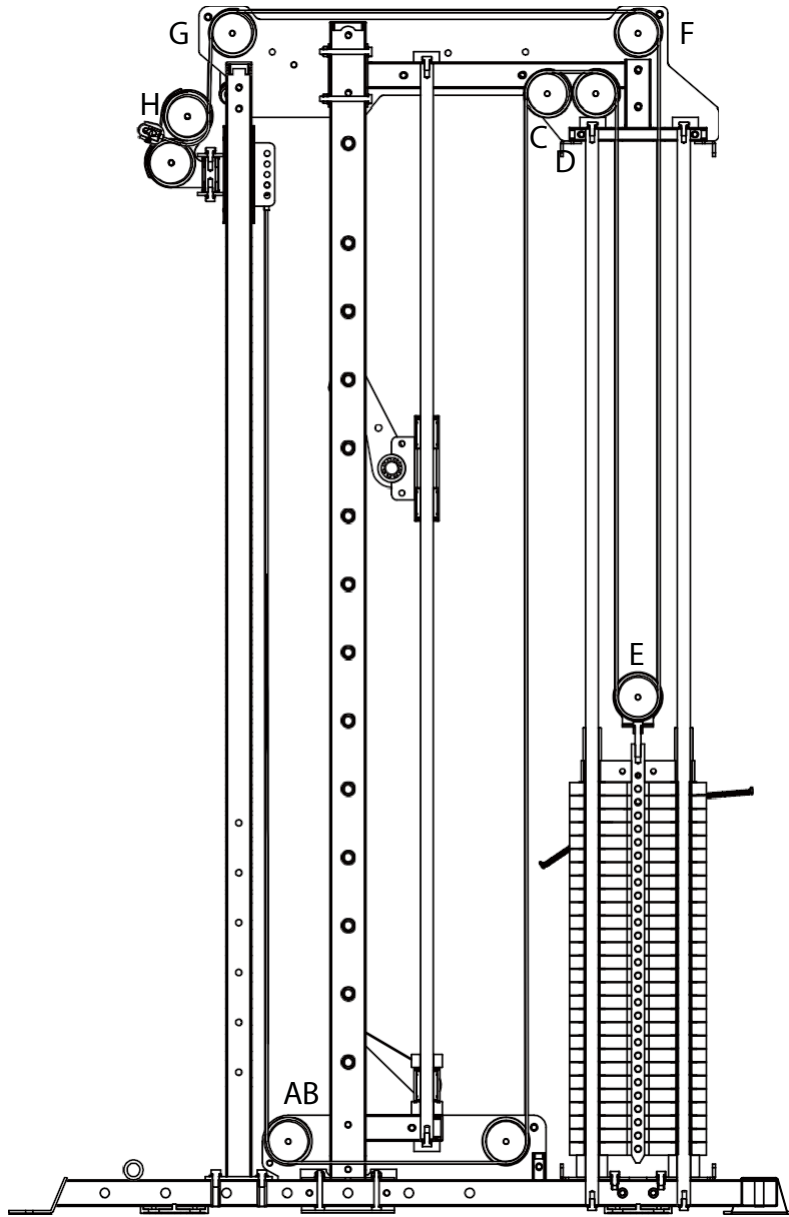

## INSTALLATION AND DISASSEMBLY DIAGRAM OF WIRE ROPE BALL HEAD

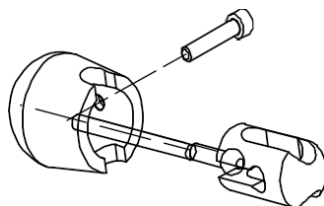

## ASSEMBLY STEP 7 INSTRUCTION DRAWING

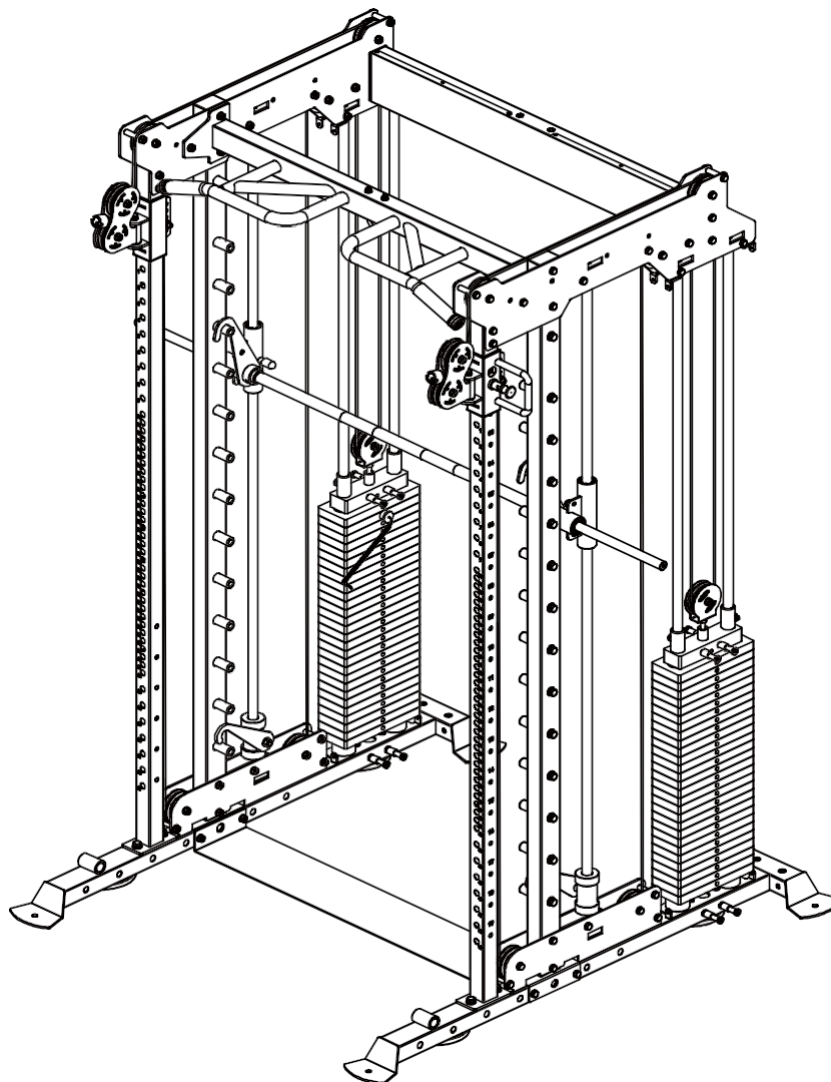

1. Disassemble the ball ends of the safety hook left (44) of the wire rope according to the requirements in the picture, and pass through and combine in ABCDEFGH order according to the picture Install 92 pulley (42) with powder sleeve (41), M10×75 hexagon bolt(30), M10 lock nut (9) fixed 92 pulley (42).
2. Reassemble the ball end of the wire rope-nose nose (44) as shown in the figure.
3. Assemble the nose end of the wire rope-nose nose (44) on the main sliding sleeve with M10 ×25 hexagon bolt (43) and  $\phi$ 10 flat washer(8), M10 lock nut (9) to secure it.
4. The left and right installation modes are the same.

# ASSEMBLY STEP 8 EXPLOSION DRAWING

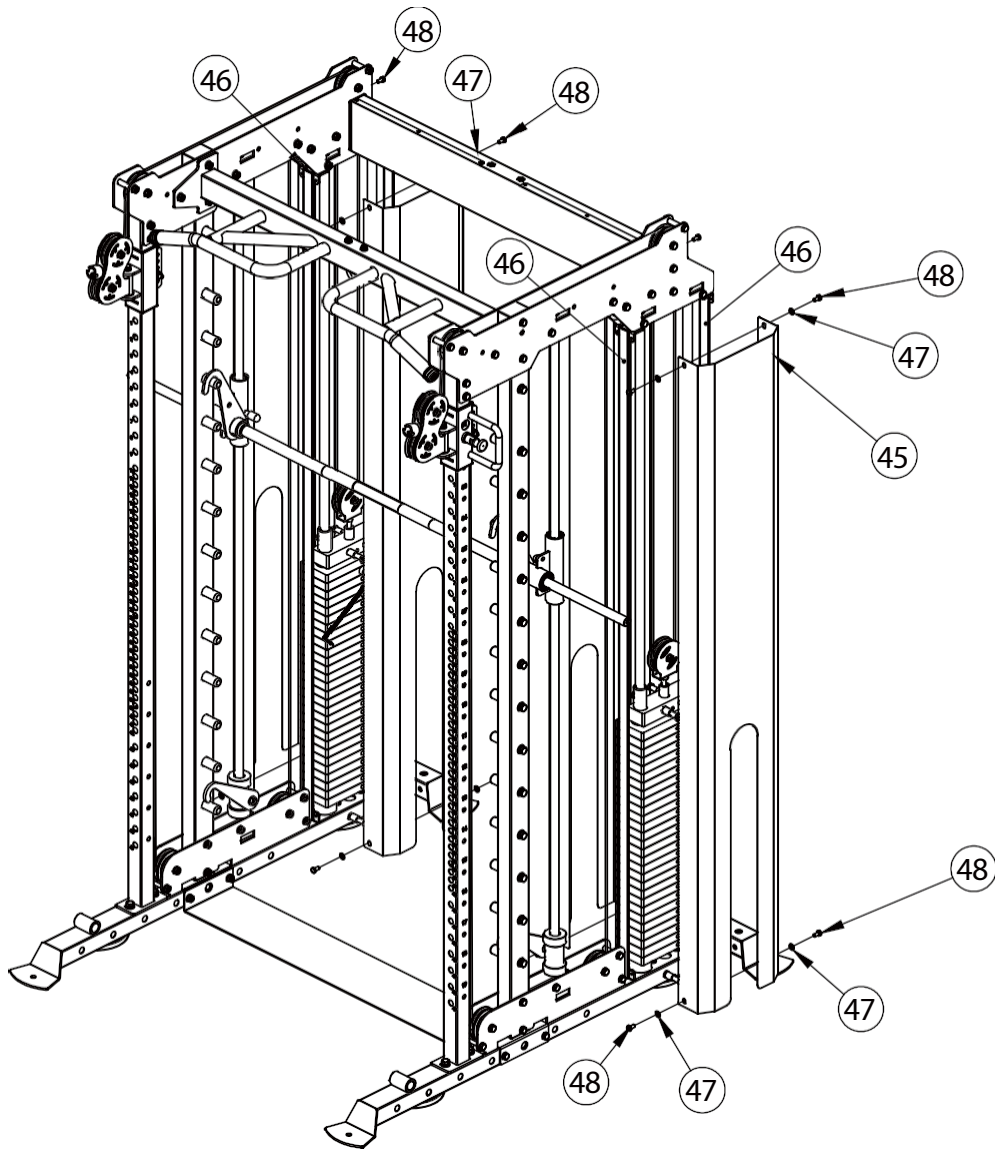

KEY NUMBER	DESCRIPTION OF PART	QUANTITY
45	Back Shield T1	4
46	Shield Of Edge 32*1975	4
47	Flat Washer $\phi 8$	16
48	Hexagon Bolt M8*16	16

## ASSEMBLY STEP 8 INSTRUCTION DRAWING

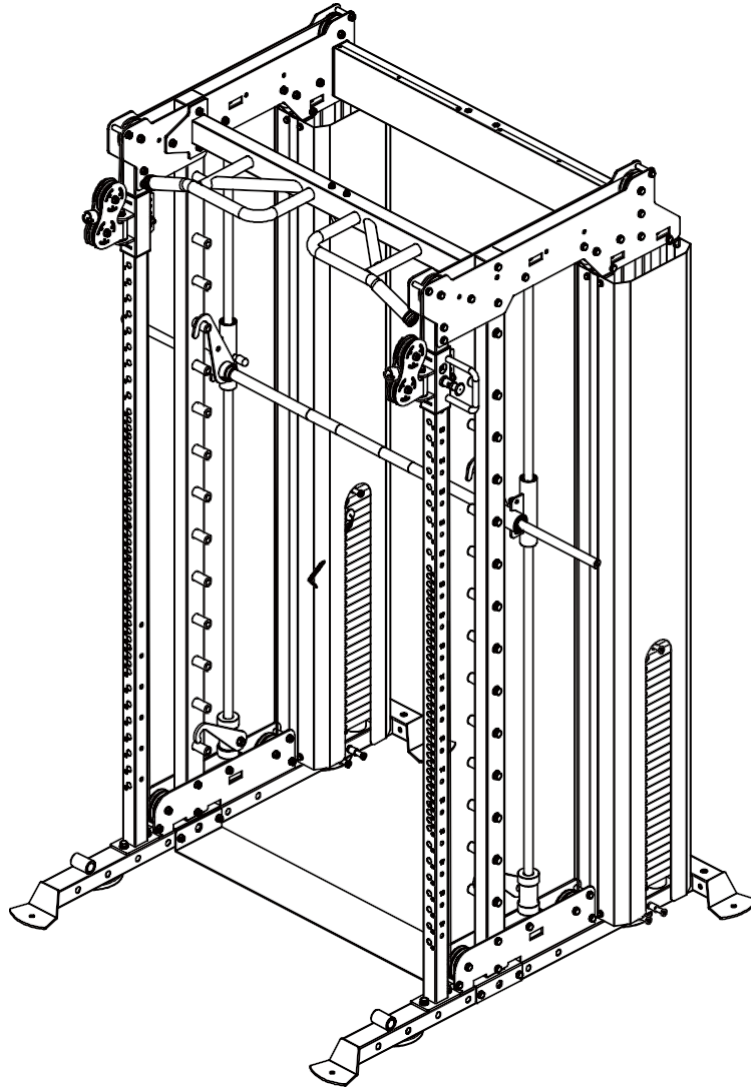

1. Assemble back shield (45) and shield of edge (46) on the main body, and fix them on the main body with M8×16 hexagon bolt (48) and  $\varnothing 8$  flat washer (47) as shown in the picture.
2. The left and right installation modes are the same.

# ASSEMBLY STEP 9 EXPLOSION DRAWING

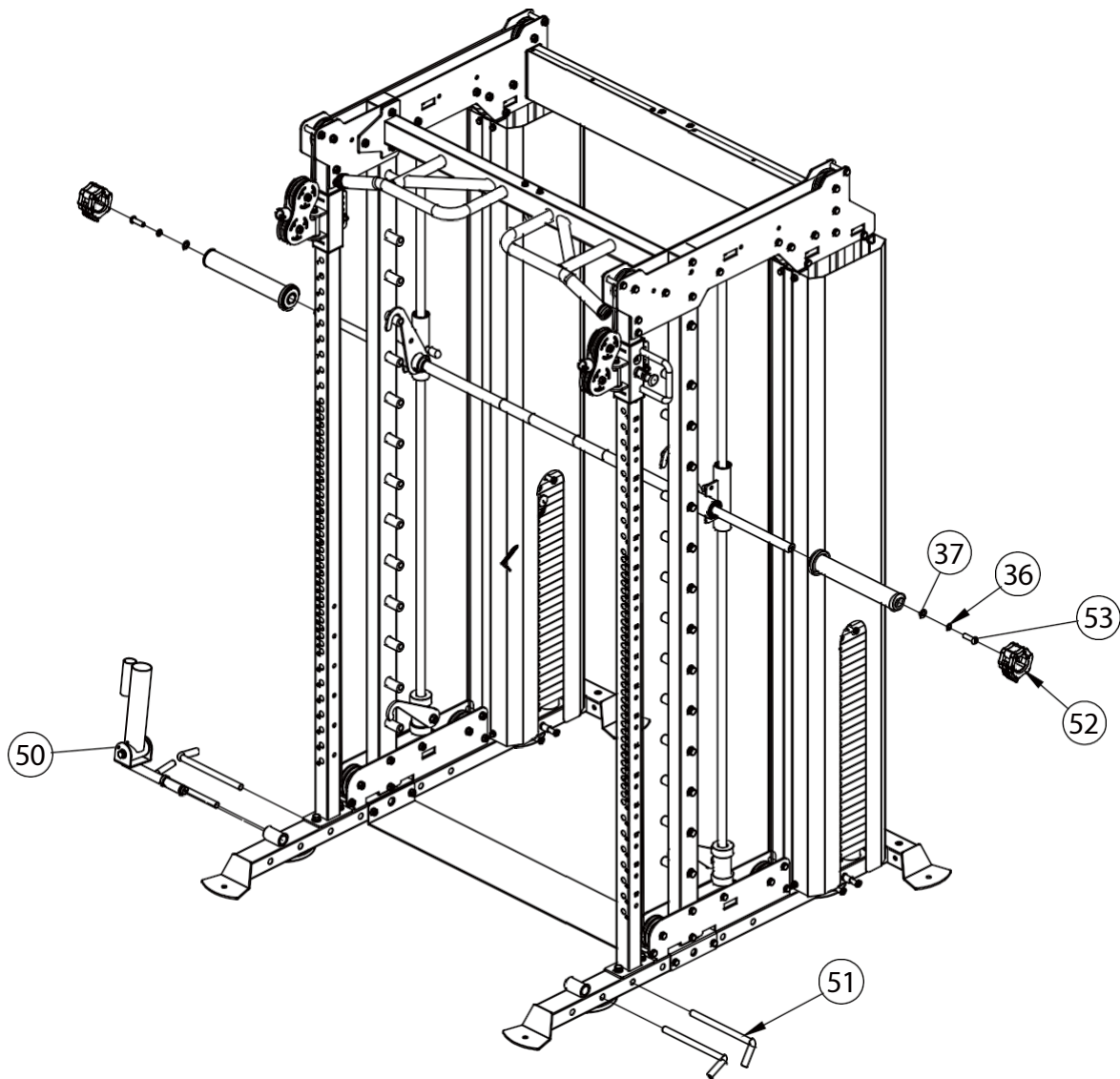

KEY NUMBER	DESCRIPTION OF PART	QUANTITY
49	Barbell Rod Sleeve	2
50	Rotation Tube	1
51	L Shape Pin $\phi 17*250*771$	4
52	Barbell Clamp $\phi 85*\phi 50x49$	2
53	Hexagon Socket Flat Round Head Screws M12*40	2
37	Flat Washer $\phi 12$	2
36	Spring Washer $\phi 12$	2

# ASSEMBLY DRAWING

BARBELL ROD SLEEVE QTY:2PCS/SET

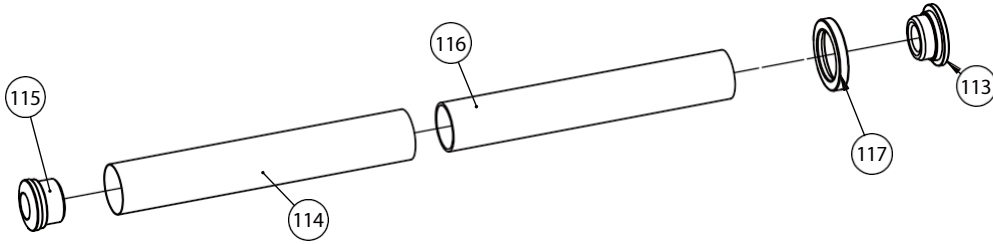

KEY NUMBER	DESCRIPTION OF PART	QUANTITY
113	Aluminum Inner Catch Collar $\phi 60 \times 27$	1
114	Stainless Outer Tube $\phi 49.5 \times 0.6$	1
115	Barbell Bar Plug $\phi 50 \times 37$	1
116	Inside Tube Of Barbell Rod $\phi 48 \times 2.5$	1
117	Rubber Ring $\phi 70 \times \phi 50 \times \phi 10$	1



# ASSEMBLY DRAWING

ROTATION TUBE QTY:1PCS/SETT

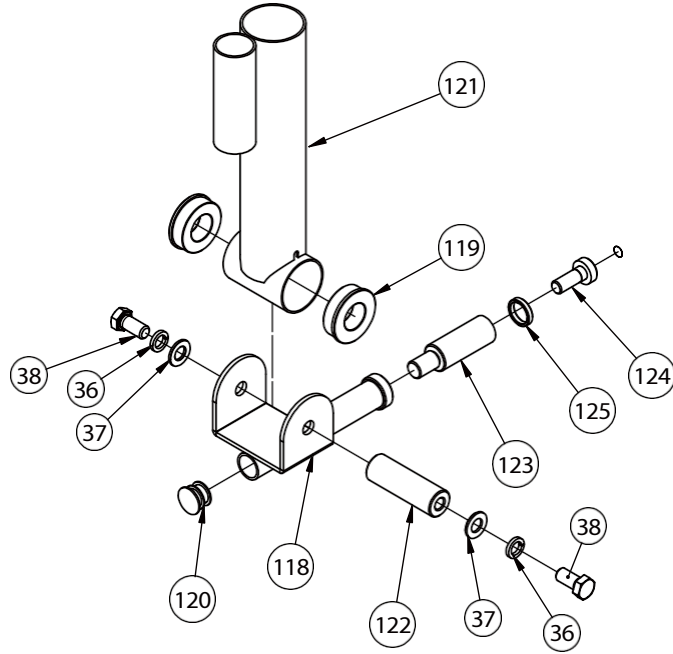

KEY NUMBER	DESCRIPTION OF PART	QUANTITY
118	New Rotation Rod	1
119	Powder Set $\phi 50 * \phi 47 * \phi 25 * 15$	2
38	Hexagon Bolt M12*25	2
120	Circle Tube Inner Plug $\phi 25 * 2$	1
37	Flat Washer $\phi 12$	2
121	Double Barbell Rotation	1
122	Inner Shaft $\phi 25 * 77 * M12$	1
123	Barbell Bar Plug $\phi 25 * 86$	1
124	Barbell Bar Limit Shaft $\phi 22 * 39.5$	1
125	Limit Ring $\phi 25 * \phi 20 * 5$	1
36	Spring Washer $\phi 12$	2

## ASSEMBLY STEP 9 INSTRUCTION DRAWING

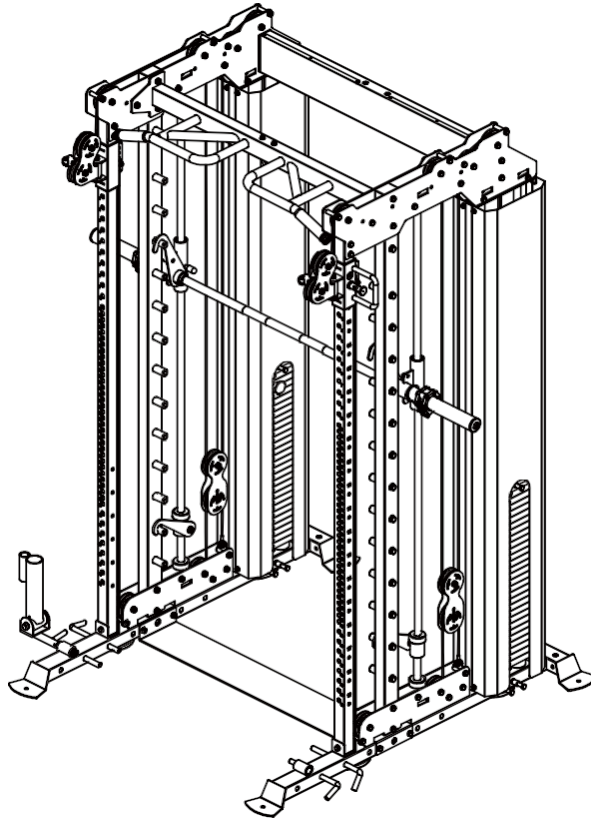

1. Assemble the rotation tube (50) on the main body.
2. Assemble the L shape pin (51) on the main body.
3. Use M12\*40 hexagon socket flat round head screws (53),  $\phi 12$  flat washer (25),  $\phi 12$  spring gasket (36) to assemble the barbell rod sleeve(49) on the main barbell rod.
4. Assemble the barbell clamp (52) on the main body.

# ASSEMBLY STEP 10 EXPLOSION DRAWING

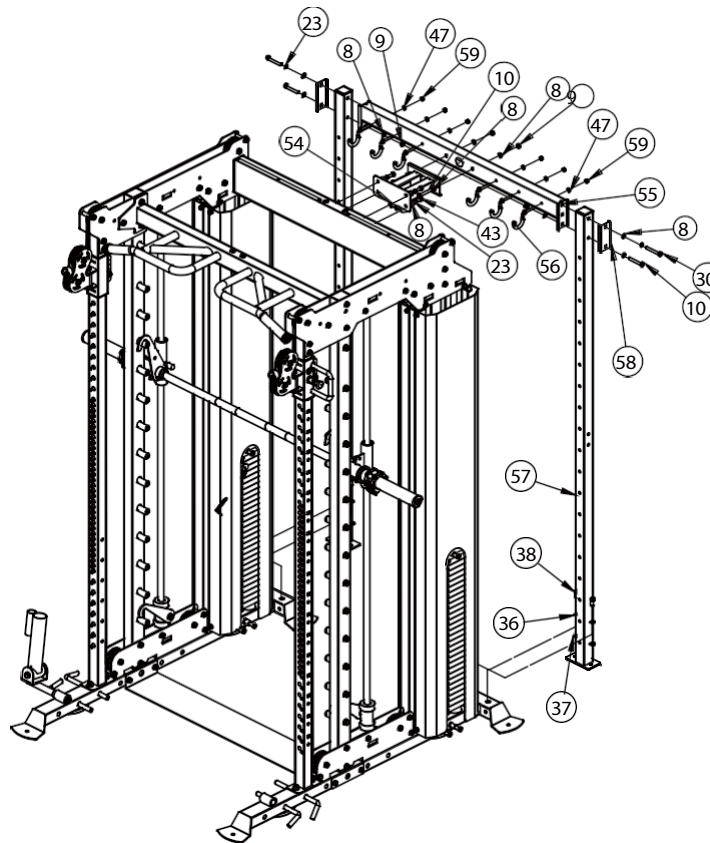

KEY NUMBER	DESCRIPTION OF PART	QUANTITY
54	Back Up Connection Tube	1
55	Pull Up The Beam Welder	1
56	Hook	6
57	Rear Column	2
58	Concave Plate T3*120*58	2
30	Hexagon Bolt M10*75	2
8	Flat Washer(Gb) $\phi$ 10	14
23	Spring Gasket $\phi$ 10	6
43	Hexagon Bolt M10*25	4
59	Lock Nut M8	6
47	Flat Washer $\phi$ 8	6
10	Hexagon Bolt M10*70	4
9	Lock Nut M10	4
38	Hexagon Bolt M12*25	4
36	Spring Washer $\phi$ 12	4
37	Flat Washer $\phi$ 12	4

# ASSEMBLY DRAWING

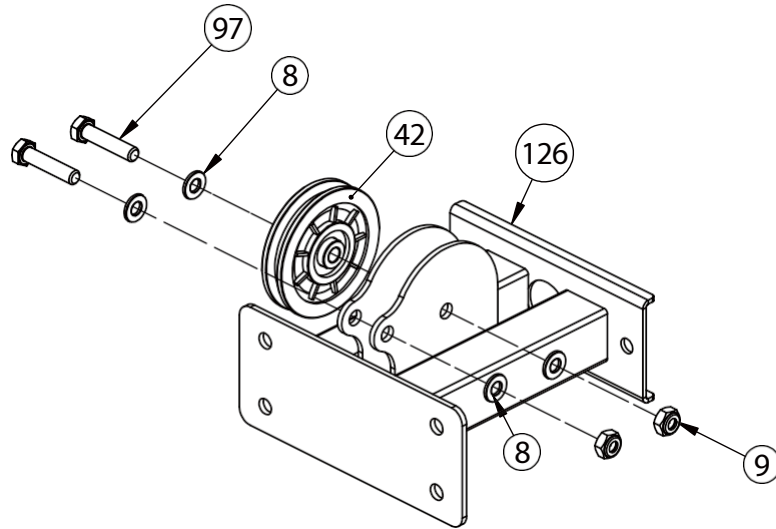

KEY NUMBER	DESCRIPTION OF PART	QUANTITY
126	Back Connection Tube	1
42	Pulley $\phi 92$	1
97	Hexagon Bolt M10*45	2
8	Flat Washer(Gb) $\phi 10$	4
9	Lock Nut M10	2

HOOK QTY:6PCS/SET

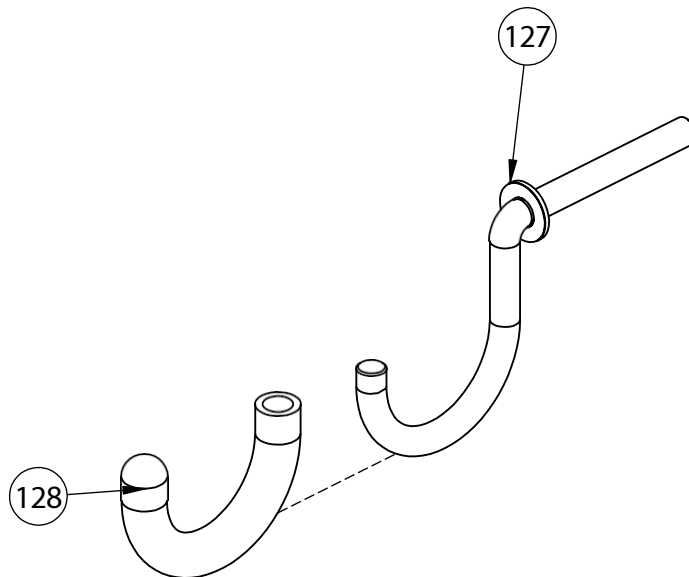

KEY NUMBER	DESCRIPTION OF PART	QUANTITY
127	Hook	1
128	Hook Handle Cover $\phi 8*100$	1

# ASSEMBLY DRAWING

REAR COLUMN QTY:2PCS/SET

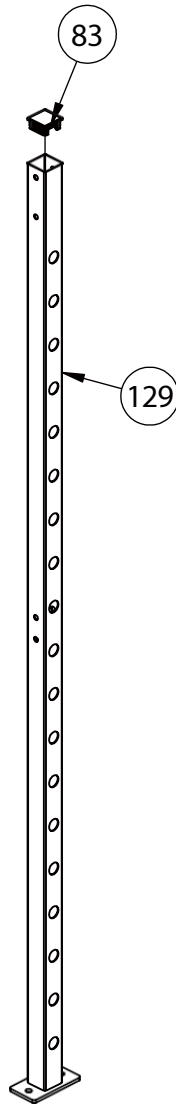

KEY NUMBER	DESCRIPTION OF PART	QUANTITY
129	Back Stand Tube	1
83	Square Tube Plug 50*50*2	1

# ASSEMBLY STEP 10 INSTRUCTION DRAWING

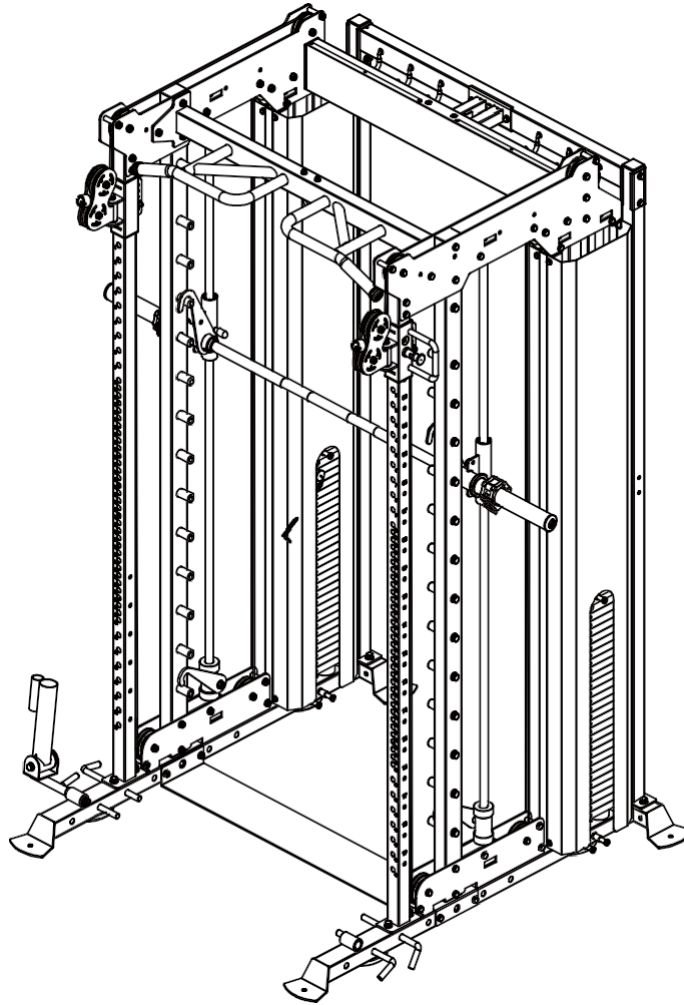

1. Use M10\*25 hexagon bolt (43),  $\phi$ 10 flat washer (8),  $\phi$ 10 spring washer (23) to assemble back up connection tube (54) to the main frame.
2. Use  $\phi$ 8 flat washer (47) and M8 lock nut (59) to assemble hook (56) to pull up the beam welder (55).
3. Use M10\*70 hexagon bolts (10),  $\phi$ 10 flat washers (8), and M10 lock nuts (9) to assemble pull up the beam welder (55) to back up connection tube (54).
4. Use M12\*25 outer hexagonal bolt (43),  $\phi$ 12 flat washer (37),  $\phi$ 12 spring washer (36) to assemble the rear column of 3070 (57) to the main frame.
5. Use M10\*75 hexagon bolt (30),  $\phi$ 10 flat washers (8),  $\phi$ 10 spring gaskets (23) to assemble rear column (57) to pull up the beam welder (55).
6. Use M10\*70 hex bolts (10)  $\phi$ 10 flat washer (8), M10 lock nut (9) to assemble rear column (57) to pull up the beam welder (55).

# ASSEMBLY STEP 11 EXPLOSION DRAWING

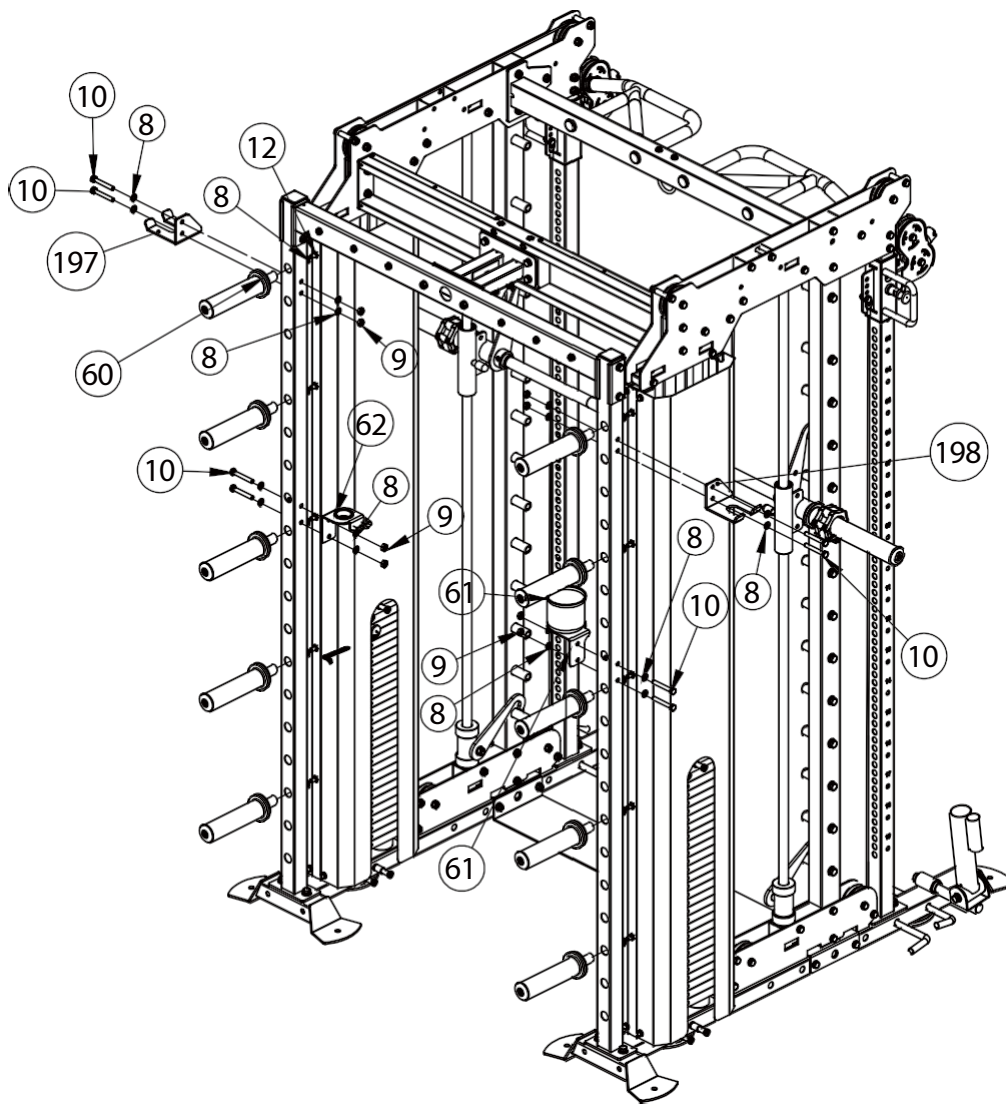

KEY NUMBER	DESCRIPTION OF PART	QUANTITY
60	Barbell Chip Hanging Rod	10
61	Kettle Fix Frame	1
62	Small Handle Fix Tube	1
10	Hexagon Bolt M10*70	8
8	Flat Washer(Gb) $\phi$ 10	26
9	Lock Nut M10	8
12	Hexagon Bolt M10*16	10
197	Right Barbell Rod Mounting Plate T5	1
198	Left Barbell Rod Mounting Plate T5	1

# ASSEMBLY DRAWING

KETTLE X FRAME QTY:1PCS/SETT

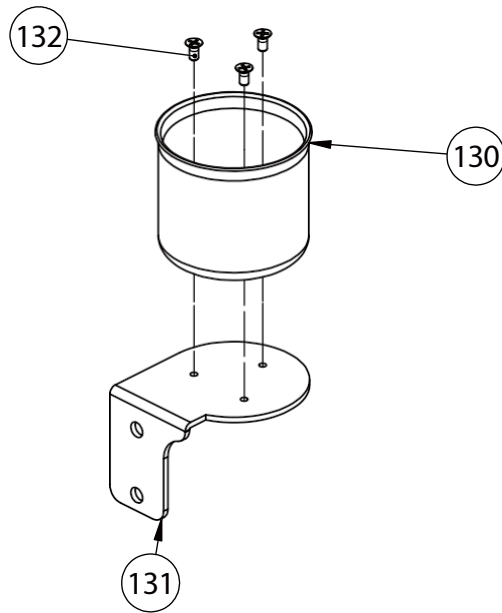

KEY NUMBER	DESCRIPTION OF PART	QUANTITY
130	Kettle Frame $\phi 100*90$	1
131	Fix Plate T4	1
132	M6*10hexagon Socket Set Screw M6*10	3

SMALL HANDLE X TUBE QTY:1PCS/SET

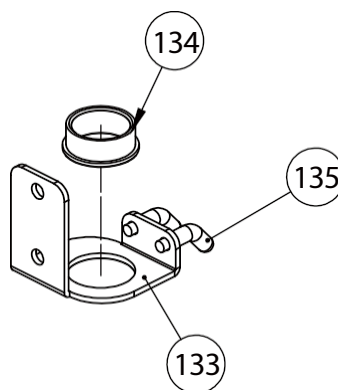

KEY NUMBER	DESCRIPTION OF PART	QUANTITY
133	Small Handle	1
134	Rubber Ring $\phi 59*\phi 39*19$	1
135	$\phi 8*45$ hook Handle Cover $\phi 8*45$	2



# ASSEMBLY DRAWING

BARBELL CHIP HANGING ROD QTY:10PCS/SET

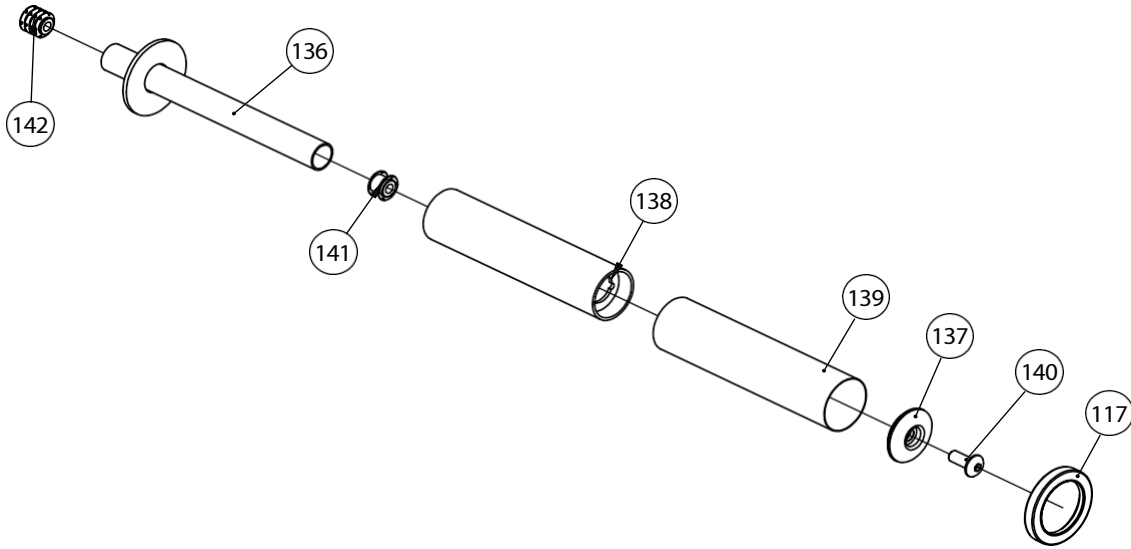

KEY NUMBER	DESCRIPTION OF PART	QUANTITY
136	Barbell Bar Tube	1
137	Decorative Aluminum Cover $\phi 11 * \phi 18 * \phi 42 * \phi 50$	1
138	Barbell Bar Tube-Aluminium Cover	1
117	Rubber Ring $\phi 70 * \phi 50 * \phi 10$	1
139	Stainless Outer Tube-200 $\phi 49.5 * 0.6 * 200$	1
140	Hexagon Socket Button Head Screws M10*25	1
141	Double Shrapnel Nut $\phi 23$ -M10 Double	1
142	Four Shrapnel Nut $\phi 23$ -M11 Four	1

# ASSEMBLY STEP 11 INSTRUCTION DRAWING

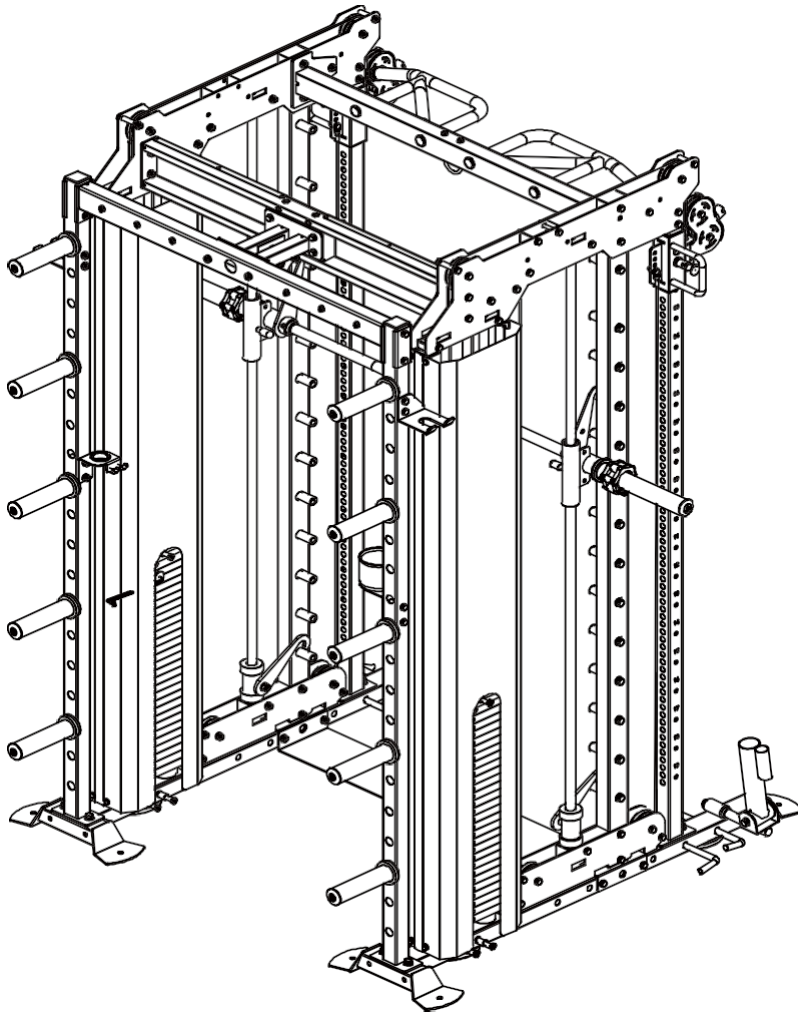

1. Use M10\*16 hexagon bolt (12) and  $\phi 10$  flat washers (8) to assemble the barbell chip hanging rod (60) on the main rack.
2. Use M10\*70 hexagon bolt(10),  $\phi 10$  flat washer (8), M10 lock nut (9) to assemble 3070 kettle mounting bracket (61) on the main rack.
3. Use M10\*70 hexagon bolt (10),  $\phi 10$  flat washer (8), M10 lock nut (9) to assemble small handle fix tube (62) on the main frame.
4. Assemble right barbell rod mounting plate (197) and left barbell rod mounting plate (198) on the main body, and fix them with M10\*70 hexagon bolt (10),  $\phi 10$  flat washers (8) and M10 lock nuts (9) wrong position.

# ASSEMBLY STEP 12 EXPLOSION DRAWING

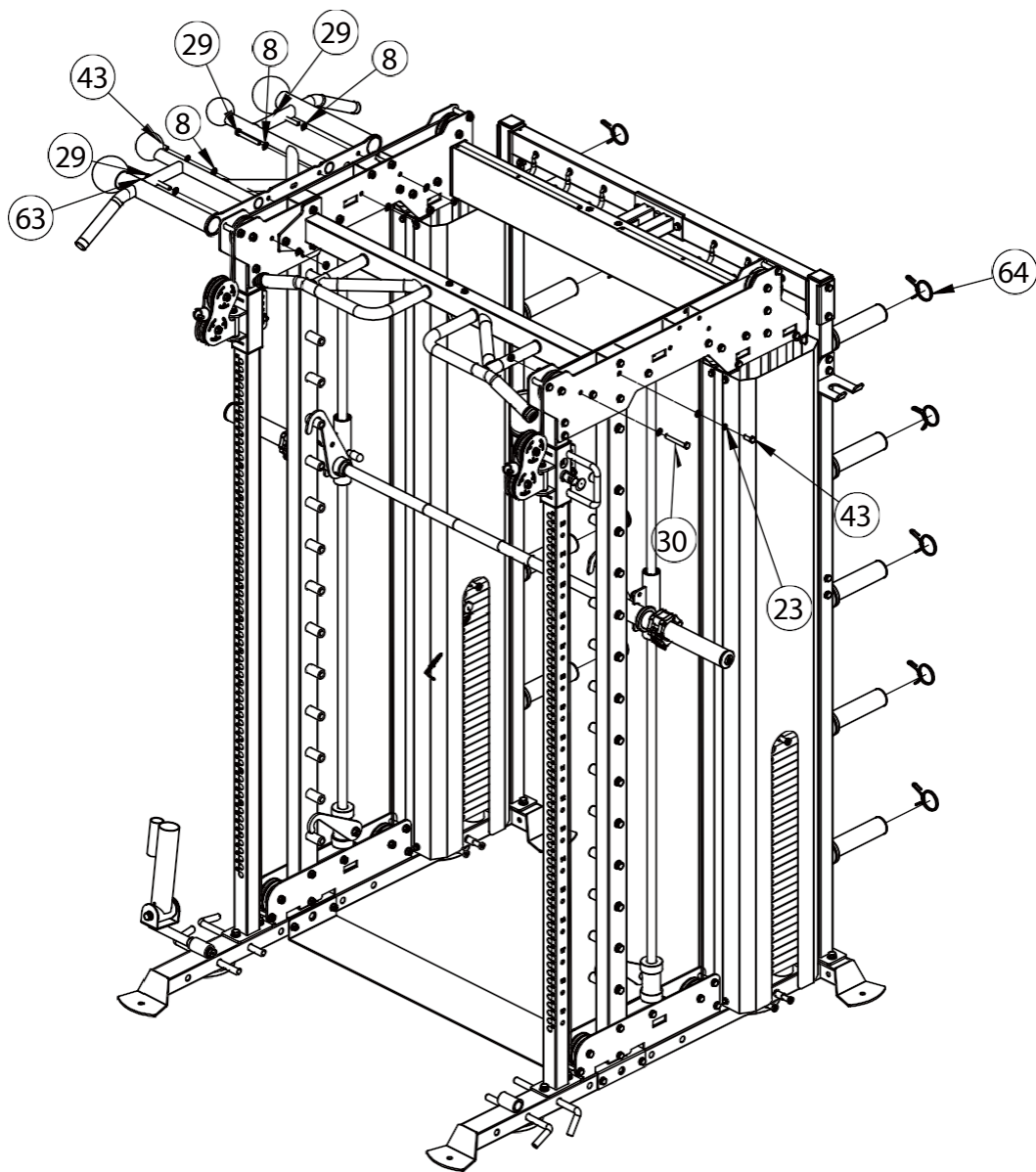

KEY NUMBER	DESCRIPTION OF PART	QUANTITY
63	Ball Shape Chin Up Bar	1
43	Hexagon Bolt M10*25	2
8	Flat Washer φ10	10
23	Spring Gasket φ10	2
29	Hexagon Bolt M10*80	3
9	Lock Nut M10	4
64	Butterfly +lip φ50	10
30	Hexagon Bolt M10*75	1

# ASSEMBLY DRAWING

BALL SHAPE CHIN UP BAR QTY:1PCS/SET

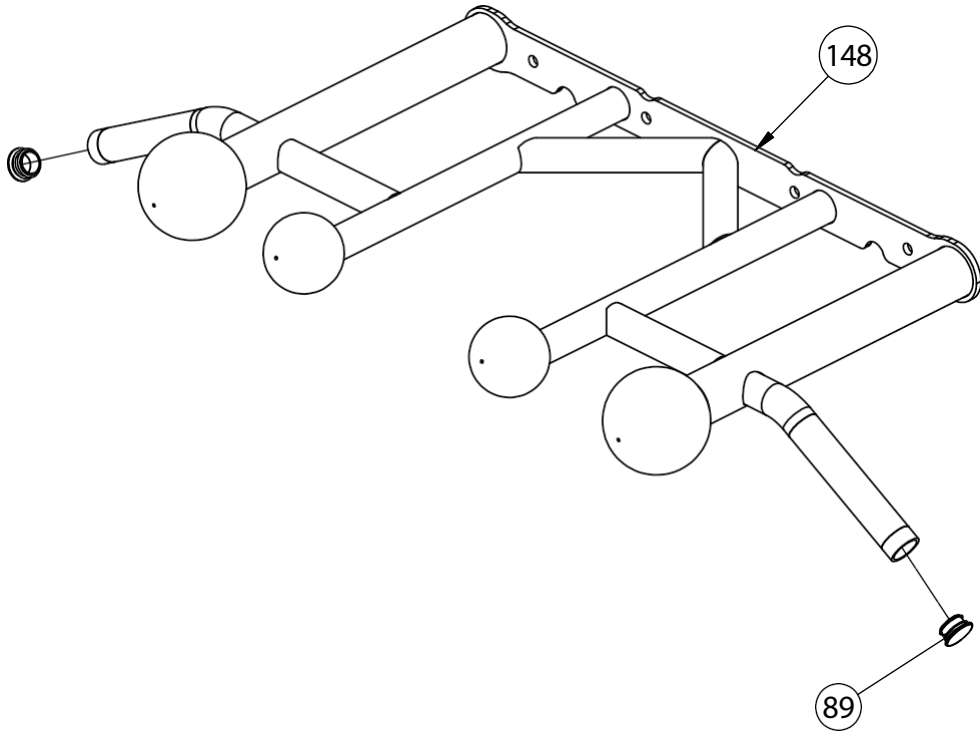

KEY NUMBER	DESCRIPTION OF PART	QUANTITY
143	Ball Shape Chin Up Bar	1
108	Circle Tube Plug $\varphi 32 \times 1.5$	2

## ASSEMBLY STEP 12 INSTRUCTION DRAWING

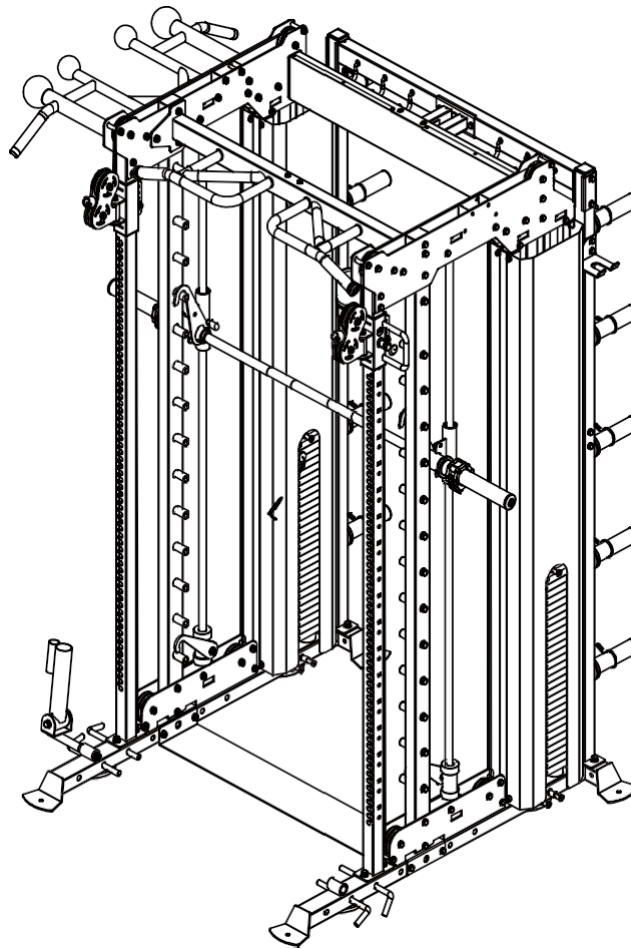

1. Use M10\*80 hexagon bolt (29), M10\*25 hexagon bolt (43),  $\phi$ 10 flat washers (8),  $\phi$ 10 spring gasket(23) and M10 lock nuts (9) to assemble the ball shape chin up bar (63) onto the main frame.
2. Assemble the  $\phi$ 50 butterfly clip (64) on the main rack.
3. As shown in the figure,  $\phi$ 10 $\times$ 75 hexagon bolt (30), M10\*25 hexagon bolt (43) and  $\phi$ 10 flat washer(8) are used on the other side ring,  $\phi$ 10 spring gasket (23) and M10 lock nut (9) are tightened and fixed.
4. Note that the ball shape chin up bar (63) can be assembled on both sides.

# ASSEMBLY STEP 13 EXPLOSION DRAWING

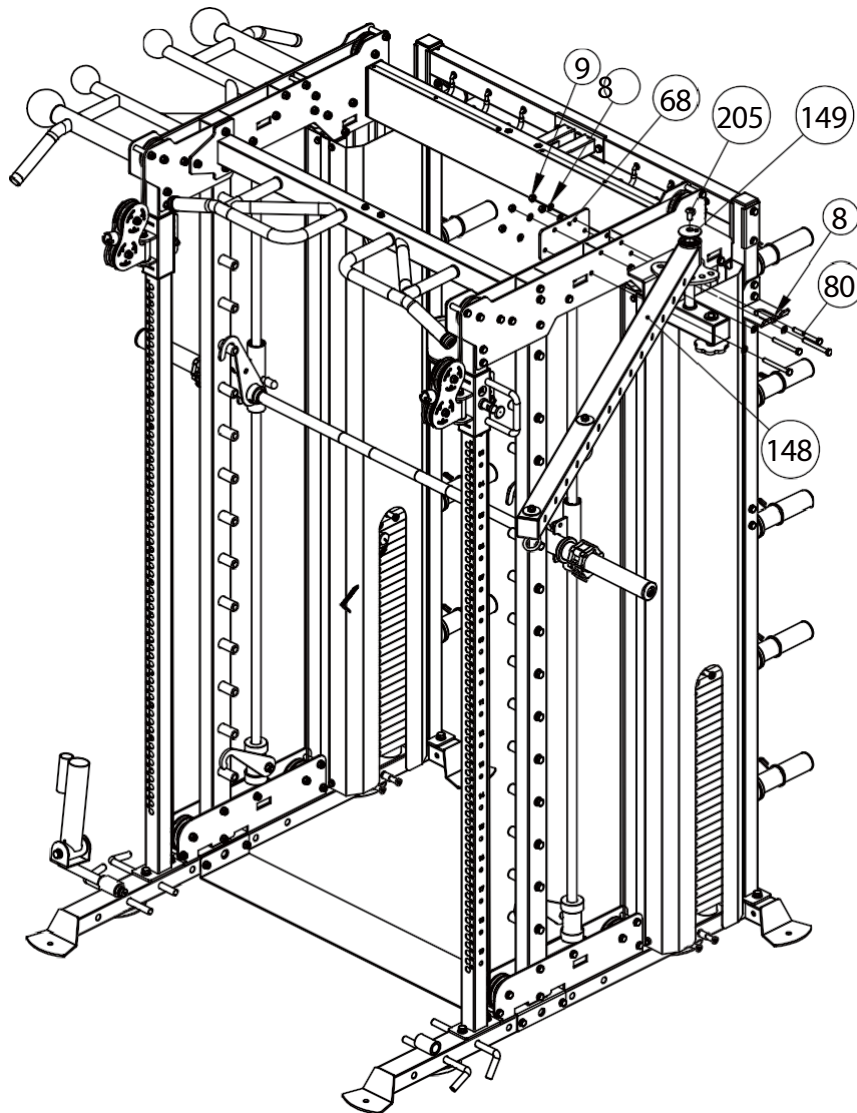

KEY NUMBER	DESCRIPTION OF PART	QUANTITY
80	Hexagon Bolt M10*90	4
8	Flat Washer(Gb) $\phi 10$	8
9	Lock Nut M10	4
147	Swing Arm Fixing Seat	1
148	Swing Arm	1
149	Decorative Aluminum Cover $\phi 11*\phi 18*\phi 28*\phi 60$	1
205	Hexagon Socket Button Head Screws M12*25	1
68	Swing Arm Fixed Reinforcement Plate T6	1

# ASSEMBLY DRAWING

## Swing ARM FIXING SEAT

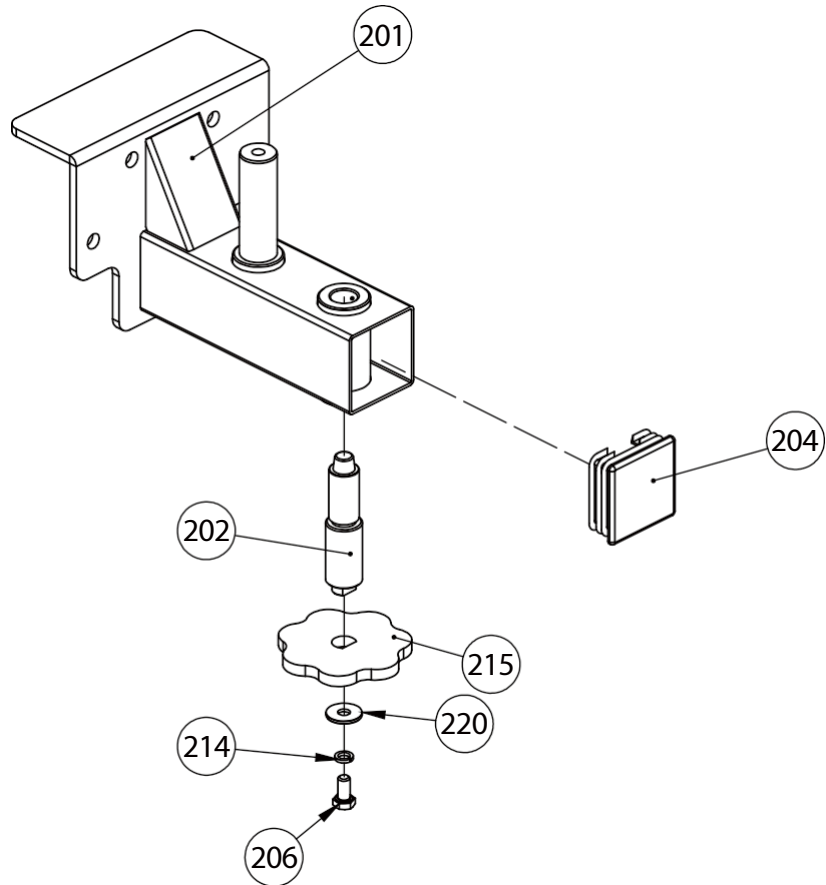

KEY NUMBER	DESCRIPTION OF PART	QUANTITY
201	Swing Arm Fixing Seat	1
202	Thread Positioning Pin $\varnothing 25 \times 102.5$	1
215	Locating Pin Knob Plate T8	1
204	Square Tube Inner Plug 60*60*2	1
220	Big Flat Washer $\varnothing 8$	1
206	Hexagon Bolt M8*16	1
214	Spring Washer $\varnothing 8$	1

# ASSEMBLY DRAWING

## Swing ARM

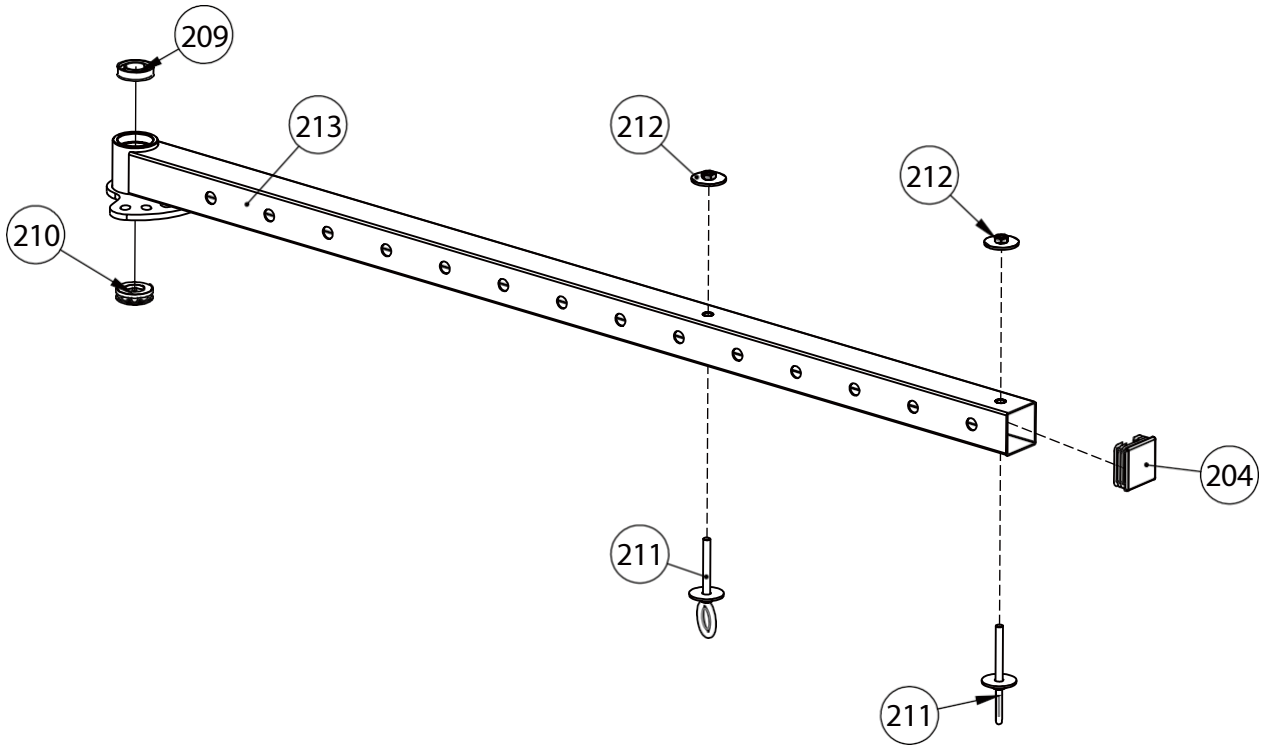

KEY NUMBER	DESCRIPTION OF PART	QUANTITY
213	Swing Arm	1
209	Bearing 6005	1
210	Thrust Ball Bearing 53205	1
211	Flying Rings	2
204	Square Tube Inner Plug 60*60*2	1
212	Washer And Nut	2



## ASSEMBLY STEP 13 INSTRUCTION DRAWING

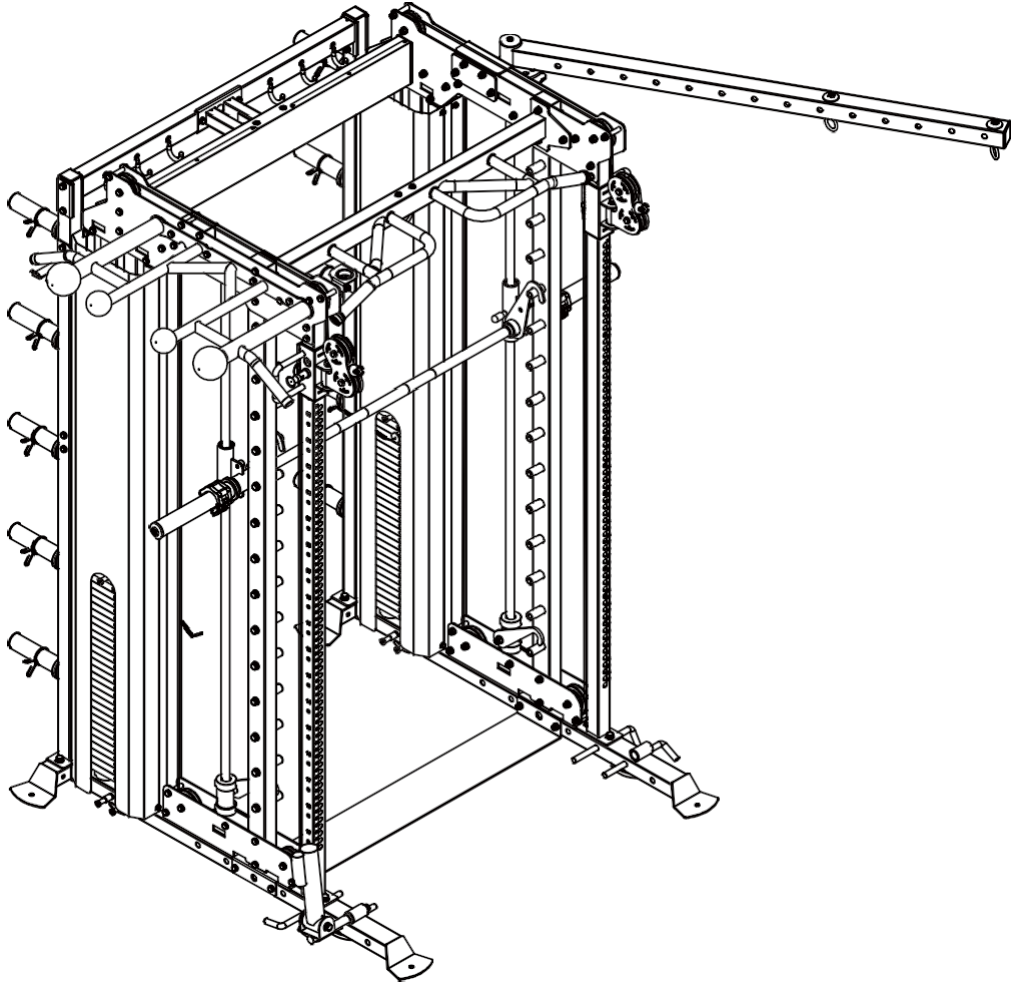

1. Use M10×90 hexagon bolt (80),  $\phi 10$  flat washer (GB) (8), M10 lock nut (9) to Swing arm fixing seat(147), Swing arm fixed reinforcement plate (68) assembled on the main body and fixed.
2. Assemble Swing arm (148) on Swing arm fixing seat (147) and use decorative aluminum cover (149).M12×25 hexagon socket button head screws (205) to fix it, pay attention to check the bearing installation during assembly.

# ASSEMBLY STEP 14 EXPLOSION DRAWING

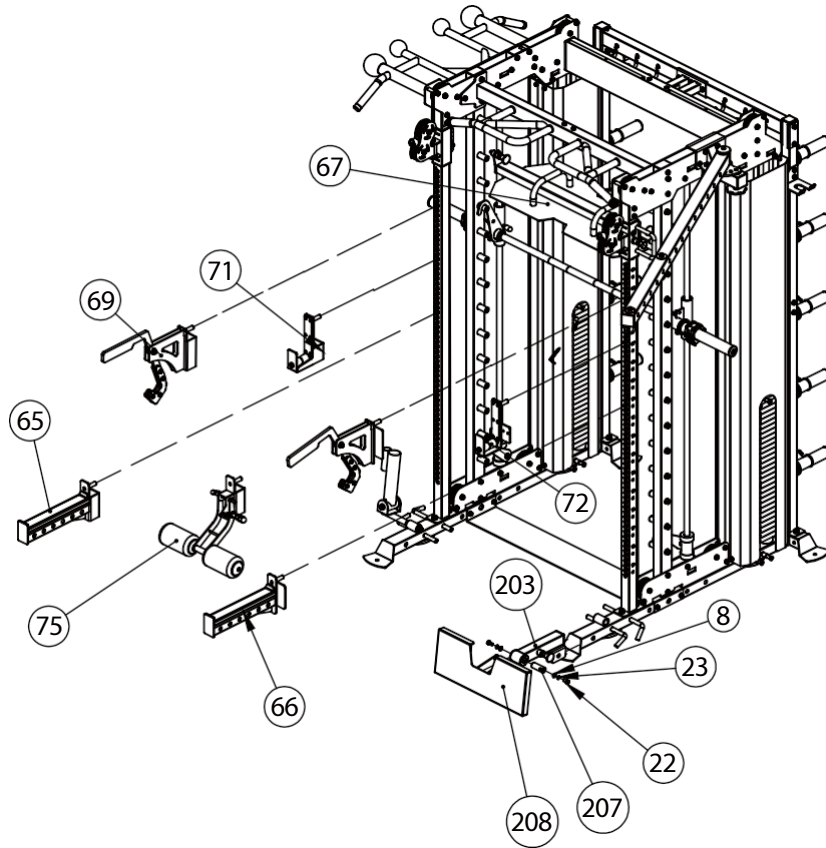

KEY NUMBER	DESCRIPTION OF PART	QUANTITY
67	Footplate	1
71	Short Safety Catch -Left	1
70	Move Hook-Right	1
69	Move Hook-Left	1
72	Short Safety Catch -Right	1
66	Left Safety Catch	1
65	Right Safety Catch	1
75	Leg Curl Tube	1
74	Leg Press Safety Catch	1
203	Pedal Fixed Assembly	1
208	Pedal Rotary Welds	1
22	Hexagon Bolt M10*20	2
23	Spring Gasket φ10	2
8	Flat Washer(Gb) φ10	2
207	Inner Shaft φ25*67-M10	1

# ASSEMBLY DRAWING

RIGHT SAFETY CATCH QTY:1PCS/SET

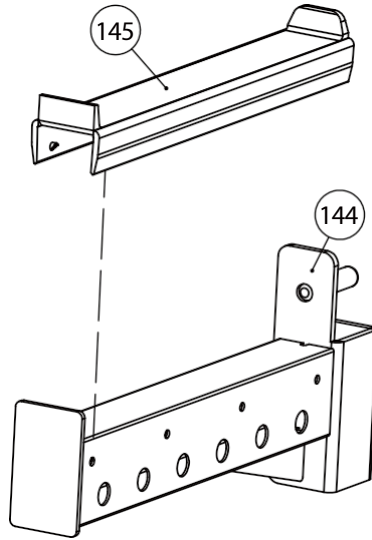

KEY NUMBER	DESCRIPTION OF PART	QUANTITY
144	Long Safety Catch-Right	1
145	Safety Catch-Outer Rubber 387	1

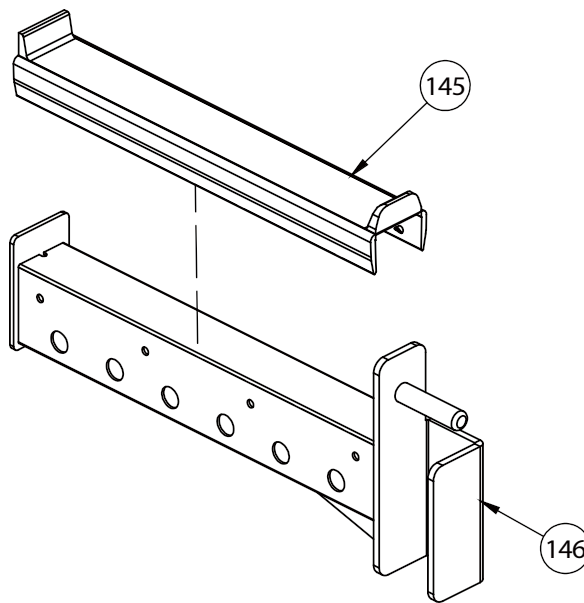

KEY NUMBER	DESCRIPTION OF PART	QUANTITY
146	Long Safety Catch-Left	1
145	Safety Catch-Outer Rubber 387	1

# ASSEMBLY DRAWING

## PEDAL FIXED ASSEMBLY

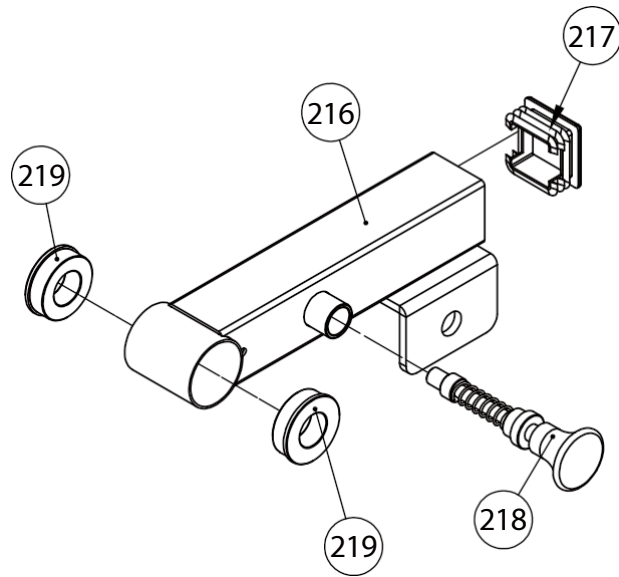

KEY NUMBER	DESCRIPTION OF PART	QUANTITY
216	Pedal Fixed Welds	1
217	Square Tube Inner Plug 50*50*2	1
218	Umbrella Head Pull Pin $\phi 12 * M20 * 75$	1
219	Powder Set $\phi 50 * \phi 47 * \phi 25 * 15$	2

## FOOTPLATE QTY:1PCS/SET

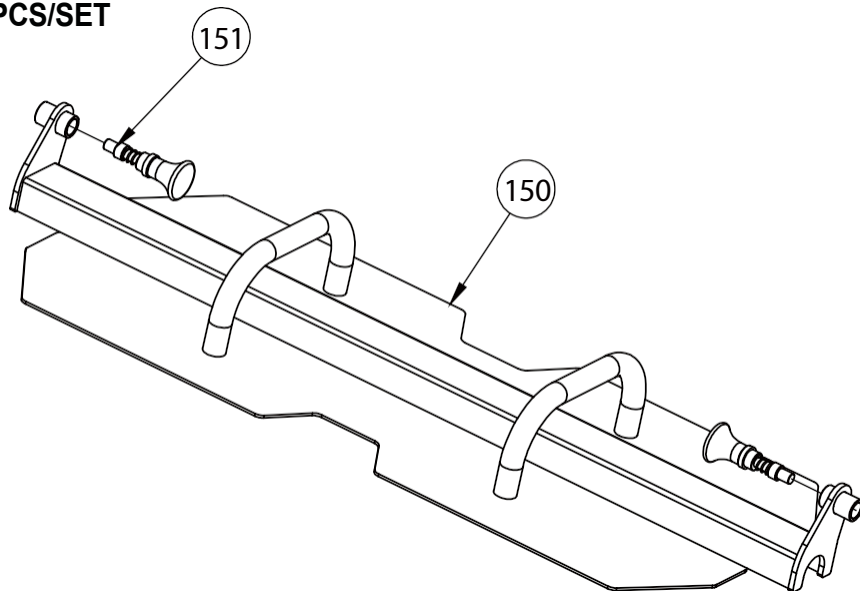

KEY NUMBER	DESCRIPTION OF PART	QUANTITY
150	Footplate	1
151	Umbrella Head Pull Pin $\phi 12 * M20 * 40$	2

# ASSEMBLY DRAWING

SHORT SAFETY CATCH -LEFT QTY:1PCS/SET

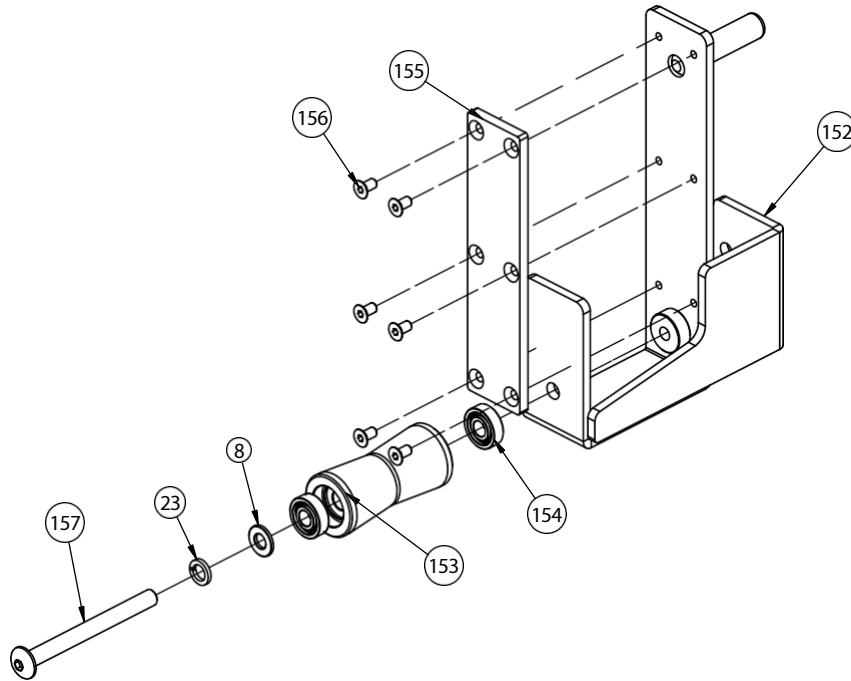

KEY NUMBER	DESCRIPTION OF PART	QUANTITY
152	Short Safety Catch -Left	1
153	Roller Shaft $\Phi 40 \times 88$	1
154	Bearing 6000	2
155	Safety Catch Rubber $\Phi 190 \times 45 \times 7$	1
156	Countersunk Head Socket Head Screw M6*12	6
157	Hexagon Socket Button Head Screws M10*110	1
8	Flat Washer(Gb) $\Phi 10$	1
23	Spring Gasket $\Phi 10$	1

# ASSEMBLY DRAWING

SHORT SAFETY CATCH -RIGHT QTY:1PCS/SET

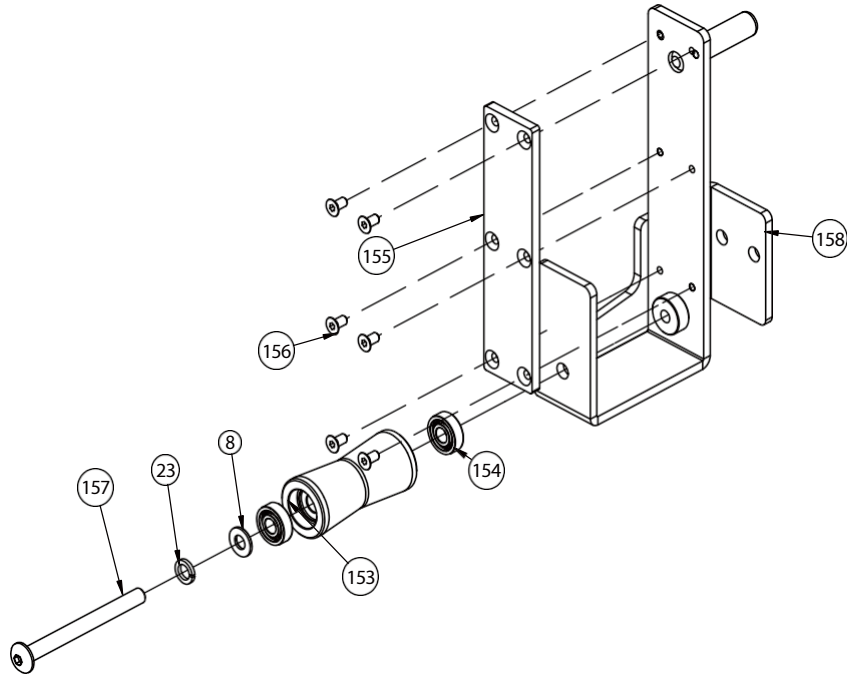

KEY NUMBER	DESCRIPTION OF PART	QUANTITY
158	Short Safety Catch -Right	1
153	Roller Shaft $\phi 40 \times 88$	1
154	Bearing 6000	2
155	Safety Catch Rubber $\phi 190 \times 45 \times 7$	1
157	Hexagon Socket Button Head Screws M10*110	1
8	Flat Washer(Gb) $\phi 10$	1
23	Spring Gasket $\phi 10$	1
156	Countersunk Head Socket Head Screw M6*12	6

# ASSEMBLY DRAWING

MOVE HOOK-LEFT QTY:1PCS/SET

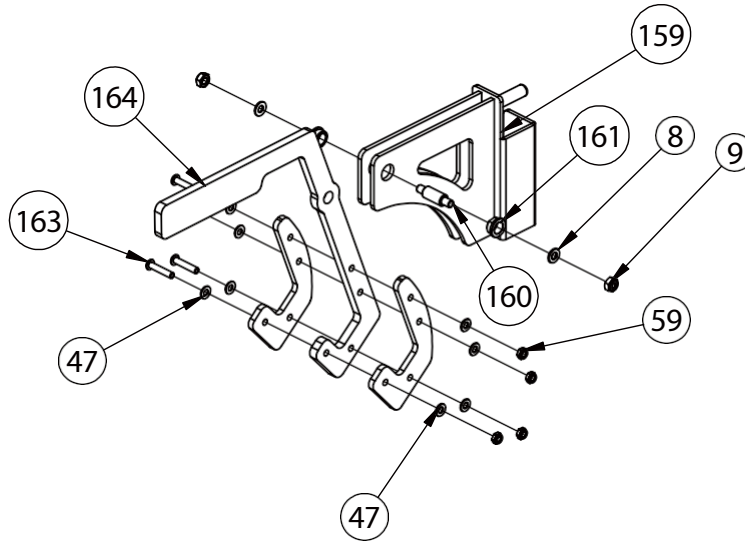

KEY NUMBER	DESCRIPTION OF PART	QUANTITY
159	Move Hook	1
160	Hook Connect Shaft $\phi 15.8 \times 59$ -M10	1
161	Powder Set $\phi 26 \times \phi 22 \times 16 \times 11$	2
8	Flat Washer(Gb) $\phi 10$	2
9	Lock Nut M10	2
164	Move Hook Plate T12	1
162	Hook Cushion T8	2
59	Lock Nut M8	4
163	Hexagon Socket Button Head Screws M8*40	4
47	Flat Washer $\phi 8$	8

# ASSEMBLY DRAWING

MOVE HOOK-RIGHT QTY:1PCS/SET

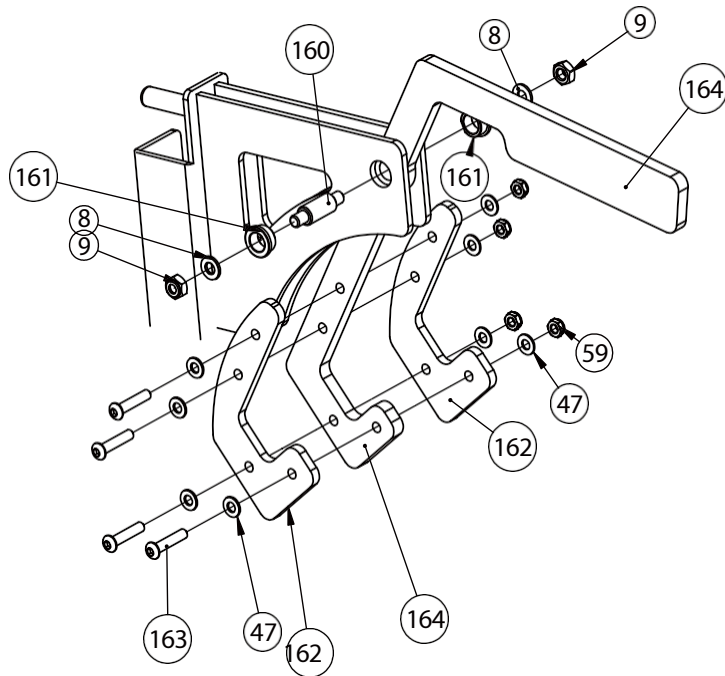

KEY NUMBER	DESCRIPTION OF PART	QUANTITY
165	Move Hook-Right	1
160	Hook Connect Shaft $\phi 15.8 \times 59$ -M10	1
161	Powder Set $\phi 26 \times \phi 22 \times 16 \times 11$	2
8	Flat Washer(Gb) $\phi 10$	2
9	Lock Nut M10	2
164	Move Hook Plate T12	1
162	Hook Cushion T8	2
59	Lock Nut M8	4
163	Hexagon Socket Button Head Screws M8*40	4
47	Flat Washer $\phi 8$	8



# ASSEMBLY DRAWING

LEG CURL TUBE QTY:1PCS/SET

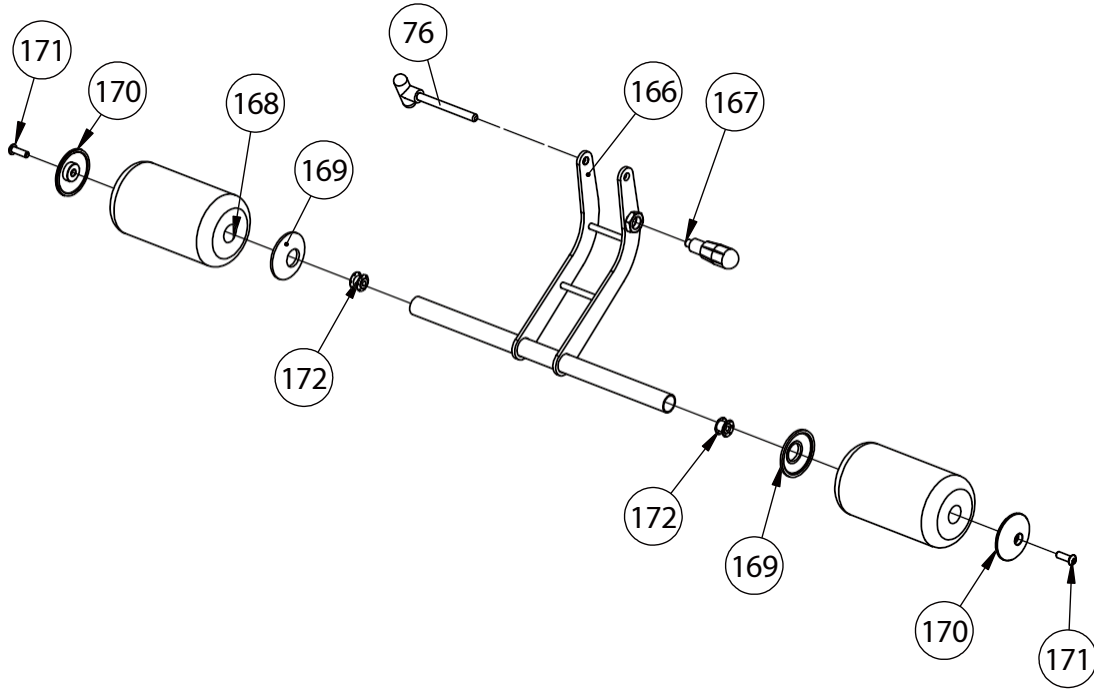

KEY NUMBER	DESCRIPTION OF PART	QUANTITY
166	Leg Press Adjust Frame	1
167	Pull Pin M18*12* φ10	1
168	Sponge φ25* φ100*175	2
169	Sponge Inner Cap φ65* φ25*12	2
170	Sponge Outer Cap φ65* φ9*12	2
171	Hexagon Socket Button Head Screws M8*25	2
172	Double Shrapnel Nut φ23-M8double	2
76	T Shape Pin φ10*100	1

## ASSEMBLY STEP 14 INSTRUCTION DRAWING

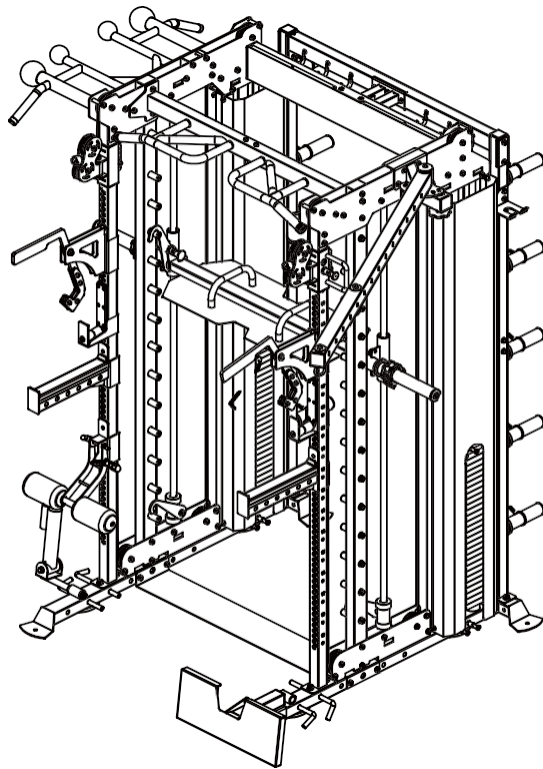

1. Inner shaft (207), M10×20 hexagon bolt (22),  $\phi$ 10 spring gasket (23),  $\phi$ 10 flat washer (GB) assembles pedal rotary welds (208) and pedal fixed assembly together.
2. Assemble the leg curl tube (75) to the leg press safety catch (74), and assemble together to the main engine.
3. Assemble right safety catch (65), left safety catch (66) and footplate (67), move hook-left (69), move hook-right (70), short safety catch -left (71), short safety catch -right (72) is installed on the main engine as shown in the figure

# CABLE ATTACHMENTS

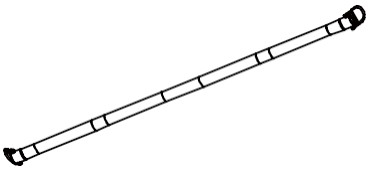

186 Long Straight Bar  
1 PCS/SET

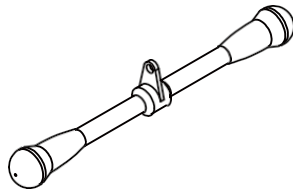

187 Short Straight Bar  
1 PCS/SET

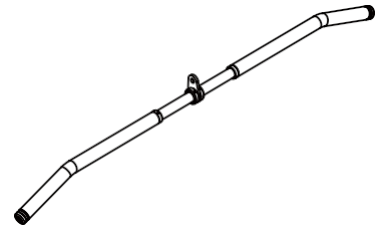

190 Last Pulldown Bar  
1 PCS/SET

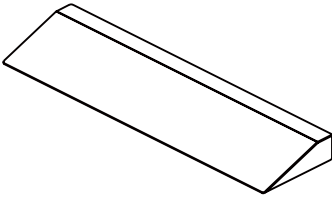

188 Calf Block  
1 PCS/SET

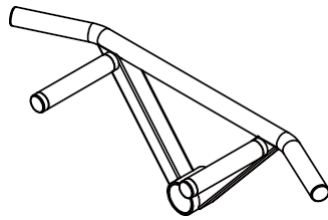

189 A Bar Row Handle  
1 PCS/SET

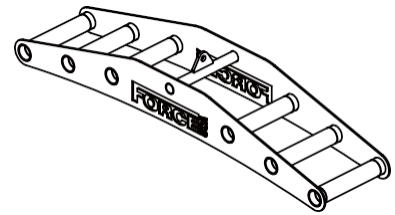

95 Multi-Grip Lat Pulldown Bar  
1 PCS/SET

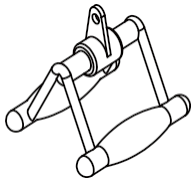

191 Close Grip Triangle  
1 PCS/SET

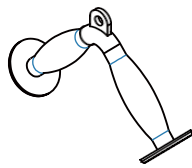

192 Tricep V Bar  
1 PCS/SET

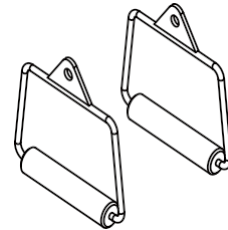

193 Metal Handle  
2 PCS/SET

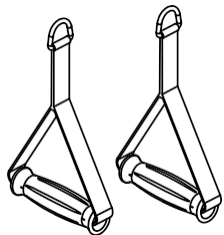

196 Nylon Handle  
2 PCS/SET

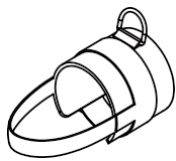

99 Ankle Cuff  
1 PCS/SET

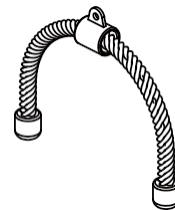

200 Tricep Rope  
1 PCS/SET

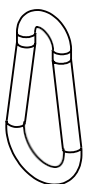

194 Carabiner  
1 PCS/SET

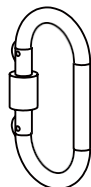

173 Oval Carabiner  
1 PCS/SET

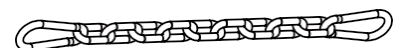

199 Chain  
1 PCS/SET

# SPARE PARTS DRAWING

## ALUMINIUM ALLOY TIE ROD 1000

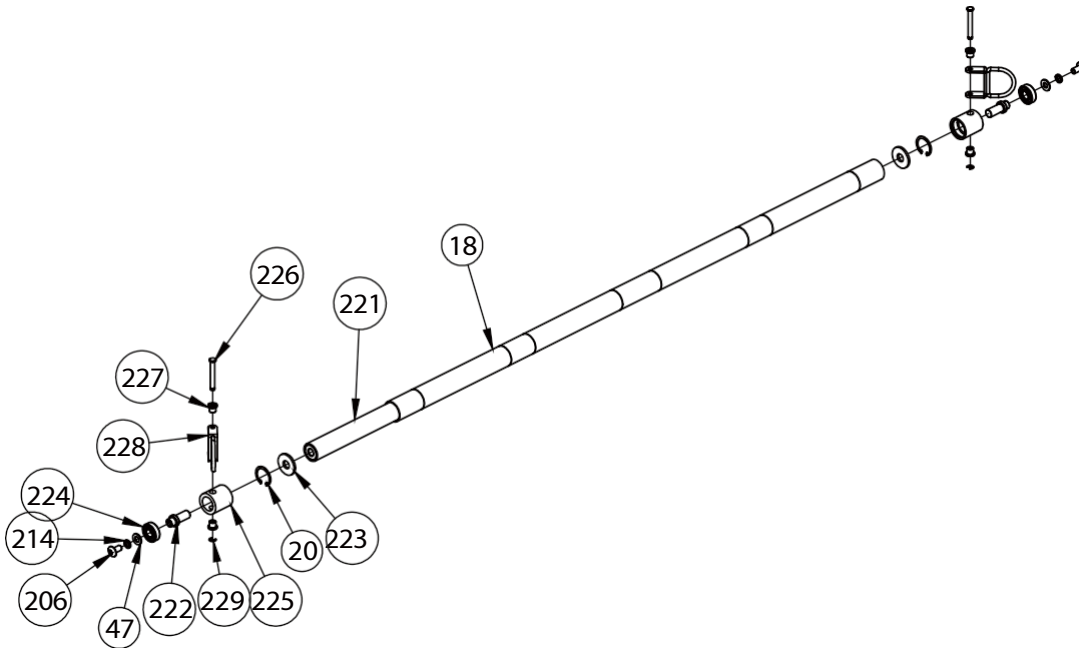

KEY NUMBER	DESCRIPTION OF PART	QUANTITY
18	Ship Rod	1
20	Spring Collar 28	2
221	Inner Lining Tube	1
222	Inner Shaft $\phi 17 \times 38$	2
223	Washer $\phi 33 \times \phi 12.5 \times T3$	2
224	Bearing 6001-2rs	2
225	Bearing Sleeve $\phi 33 \times \phi 22$	2
226	T Shape Pin $\phi 9.4 \times \phi 6.3$	2
227	T Shape Lining Sleeve $\phi 13 \times \phi 9.45$	4
228	U Shape Fastener	2
229	Catch 5	2
206	Hexagon Socket Button Head Screws M8*16	2
214	Spring Washer $\phi 8$	2
47	Flat Washer $\phi 8$	2

# SPARE PARTS DRAWING

## FOOT PAD ASSEMBLY

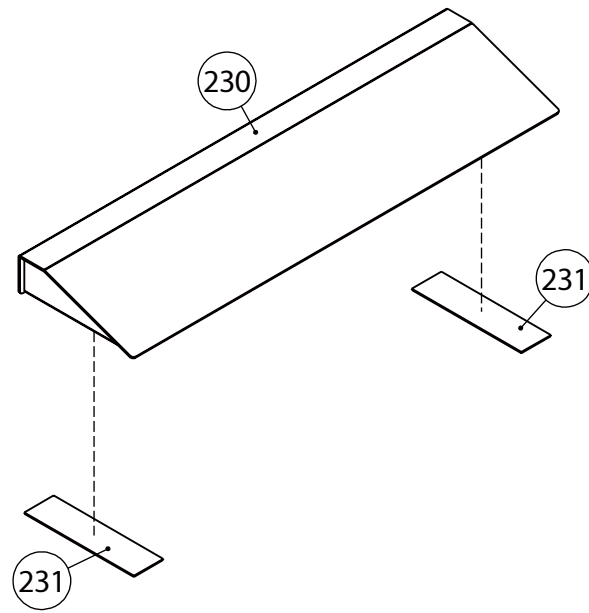

KEY NUMBER	DESCRIPTION OF PART	QUANTITY
230	Foot Pad Welds	1
231	Ev Stickers 205*55*2	

# SPARE PARTS DRAWING

## PULLER

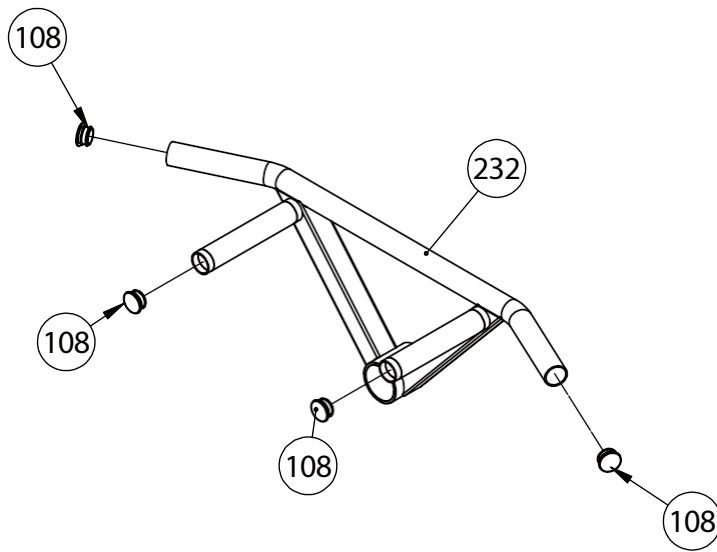

KEY NUMBER	DESCRIPTION OF PART	QUANTITY
232	Puller Handle	1
108	Circle Tube Plug $\phi 32 \times 1.5$	4

# SPARE PARTS DRAWING

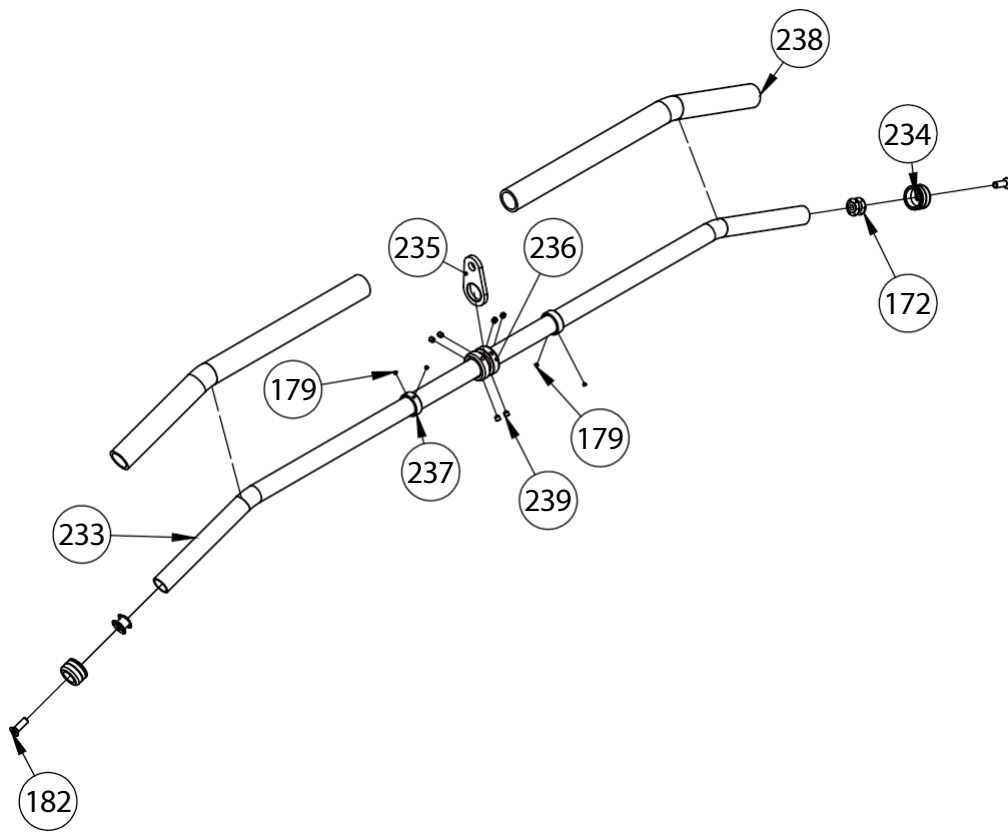

KEY NUMBER	DESCRIPTION OF PART	QUANTITY
233	Big Pull Elbow $\phi 25 \times 2$	1
234	Hand Handle Outer Baffle Ring $\phi 31.5 \times \phi 25.5$	2
172	Double Shrapnel Nut $\phi 23$ -M8double	2
235	Pull The Hanging Piece T6	1
236	Pull The Baffle Ring $\phi 39 \times \phi 26 \times 12$	2
237	Hand Handle Inner Baffle Ring $\phi 33 \times \phi 26 \times 10.5$	2
238	Handle Cover $\phi 25 \times 480$	2
239	Hexagon Socket Set Screws With Concave End M6*6	6
182	Hexagon Socket Set Screw M8*20	2
179	Hexagon Socket Screws Without Head M4*3	4