

ASSEMBLY GUIDE

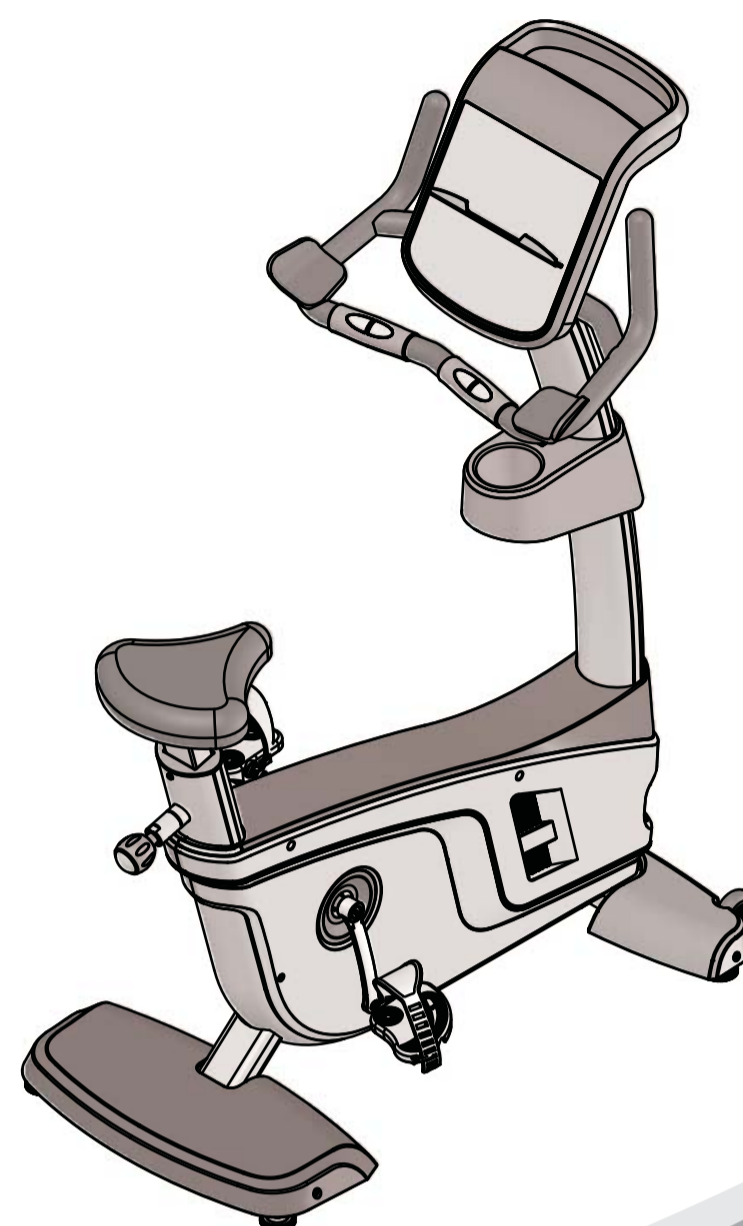

! CAUTION
Read all precautions
and instructions in this manual
before using this equipment

11X



Subassembly Parts List



Console & Handle

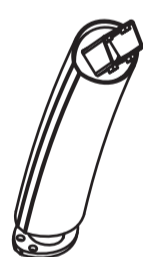

Upright



Water Bottle Holder



Water Bottle
Holder Bracket

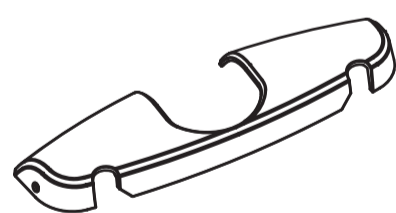

Front Base Cover

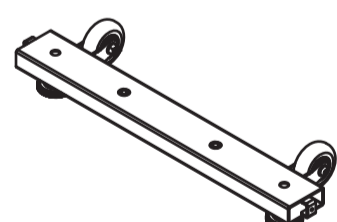

Front Base



Seat

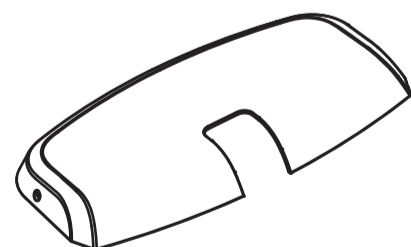

Rear Base Cover

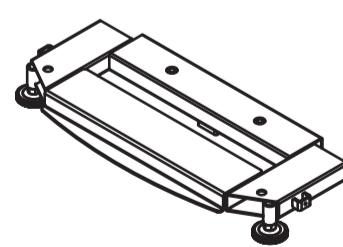

Rear Base



Pedal

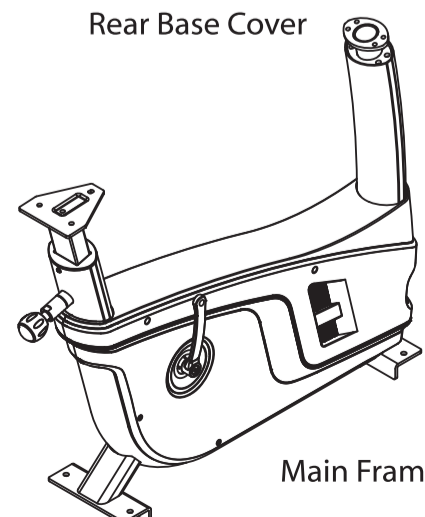

Main Frame

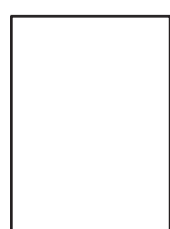

Hardware



Manual

Hardware List

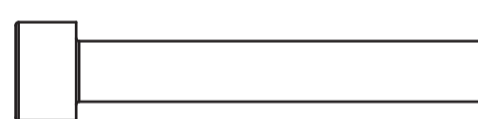

two M8*55 Socket Head Cap Screw (#66)



four $\Phi 9 \times \Phi 16 \times 1.6$ Washer (#22)

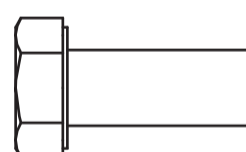

eight M10*25 Hex Head Bolt (#50)



eight $\Phi 10$ Spring Washer (#61)

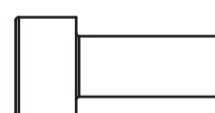

two M8*20 Socket Head Cap Screw (#67)



four $\Phi 10$ Spring Washer (#62)



four M5*12 Screw (#24)

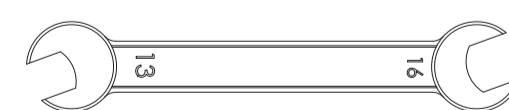

one Wrench (#70)

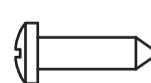

four ST4.2*16 Screw (#49)



one S=6 Hex Key (#72)

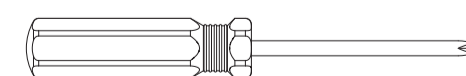

one Wrench (#71)

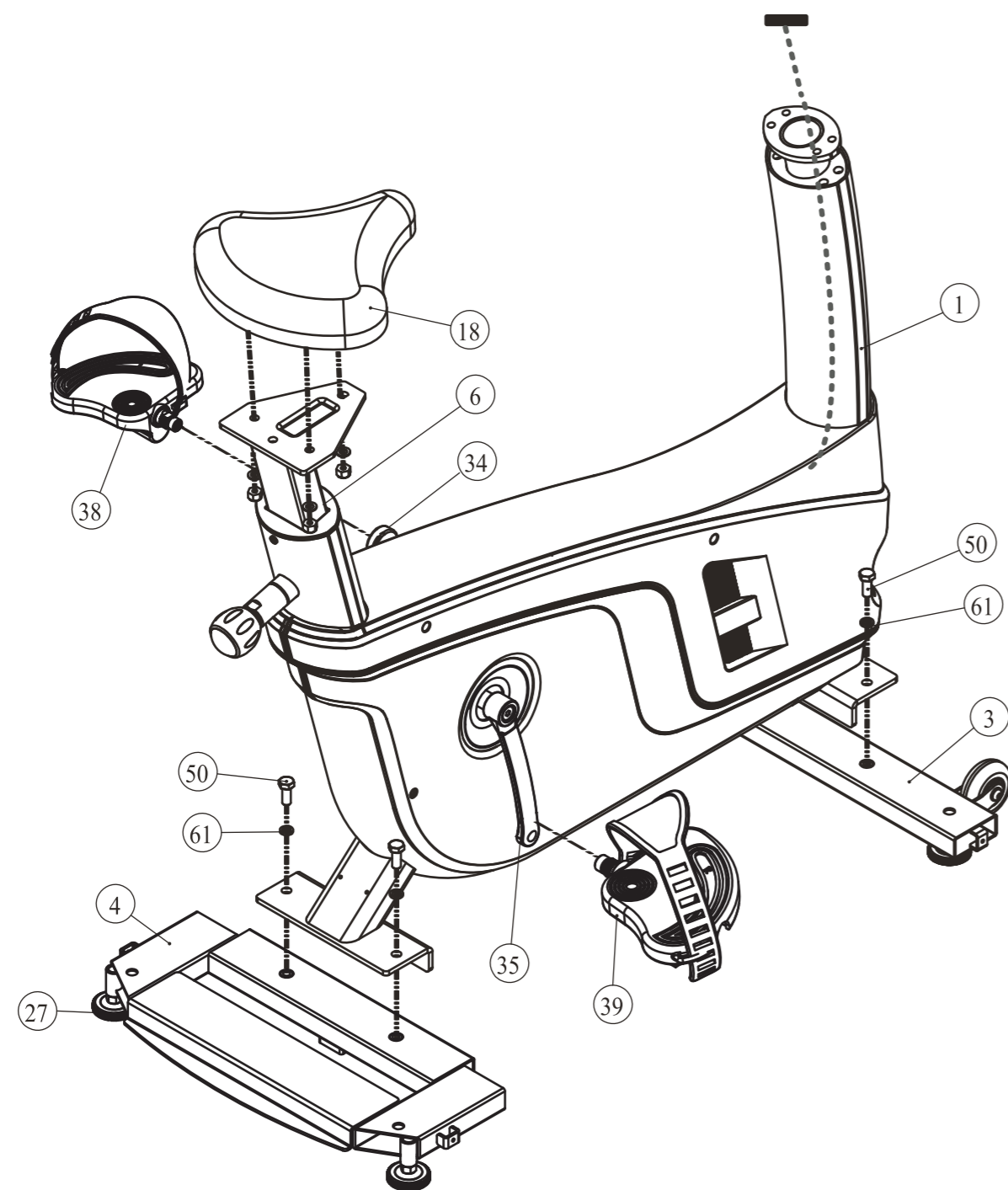

Step 1

1. Fixing Front Base (#3) and Rear Base (#4) to Main Frame (#1) using:
four M10*25 Hex Bolt (#50)
four Φ 10 Spring Washer (#61)
adjusting the Adjusting Pad (#27) to keep the balance of Main Frame.
2. Fixing the Seat (#18) to Seat Support Post (#6) using:
three Φ 9* Φ 16*1.6 Washer
three M8 Nut
The seat contains the two kinds of hardware.
3. Attach Left Pedal (#38) and Right Pedal (#39) to the Main Frame (#1) lock tightly.

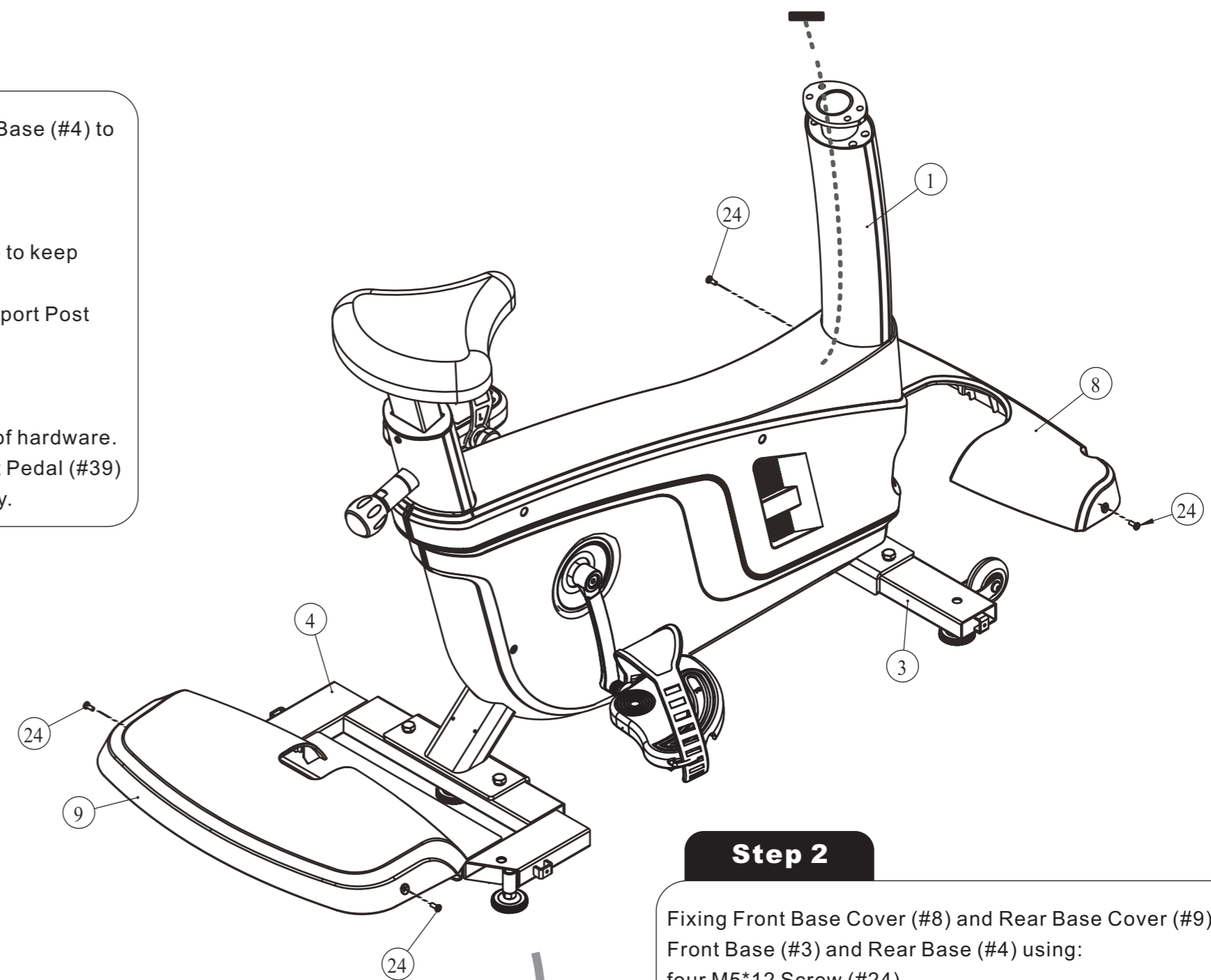

Step 2

- Fixing Front Base Cover (#8) and Rear Base Cover (#9) to Front Base (#3) and Rear Base (#4) using:
four M5*12 Screw (#24)

Step 4

1. Attach Upper Harness (#E20) to Bottom Harness (#E31).
2. Fixing Upright (#2) to Main Frame (#1) using:
two Φ 10 Spring Washer (#61)
two M10*25 Hex Head Bolt (#50)
lock the front two holes.
3. Fixing Cup Holder Support (#15) Upright (#2) using:
two Φ 10 Spring Washer (#61)
two M10*25 Hex Head Bolt (#50)
lock the front two holes.
4. Fixing Cup Holder (#14) to Cup Holder Support (#15) using:
two ST2.9*16 Screw (#49)

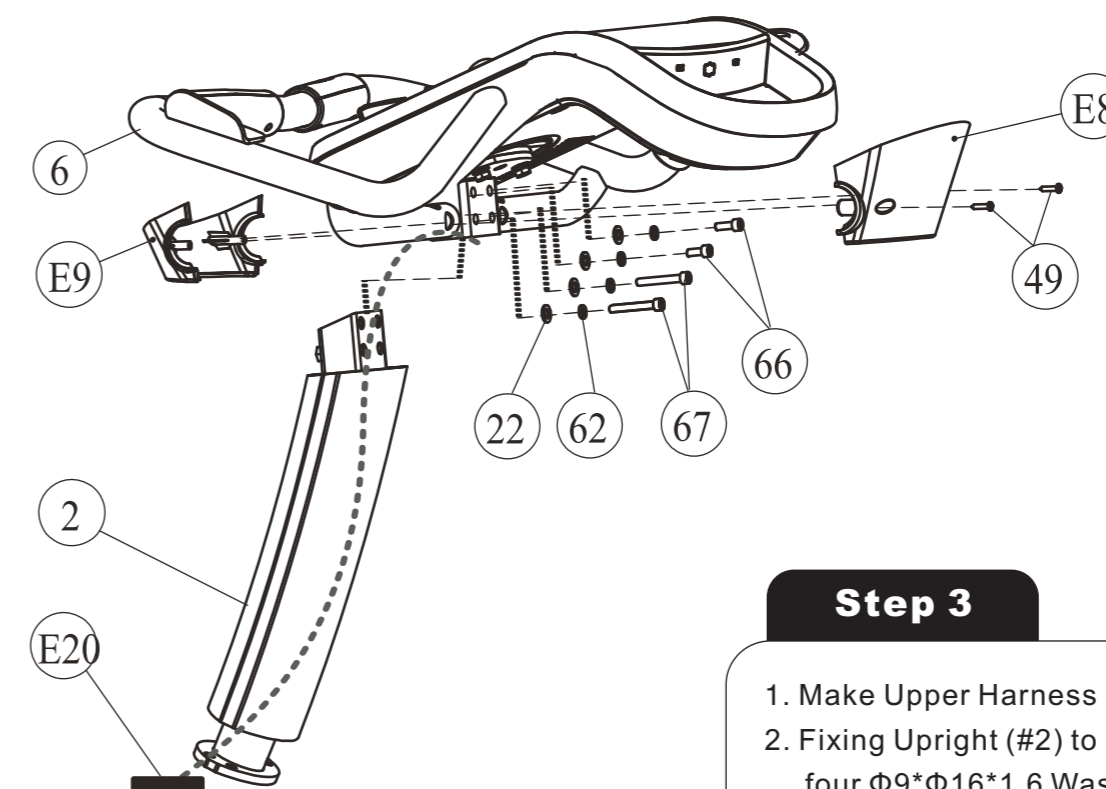
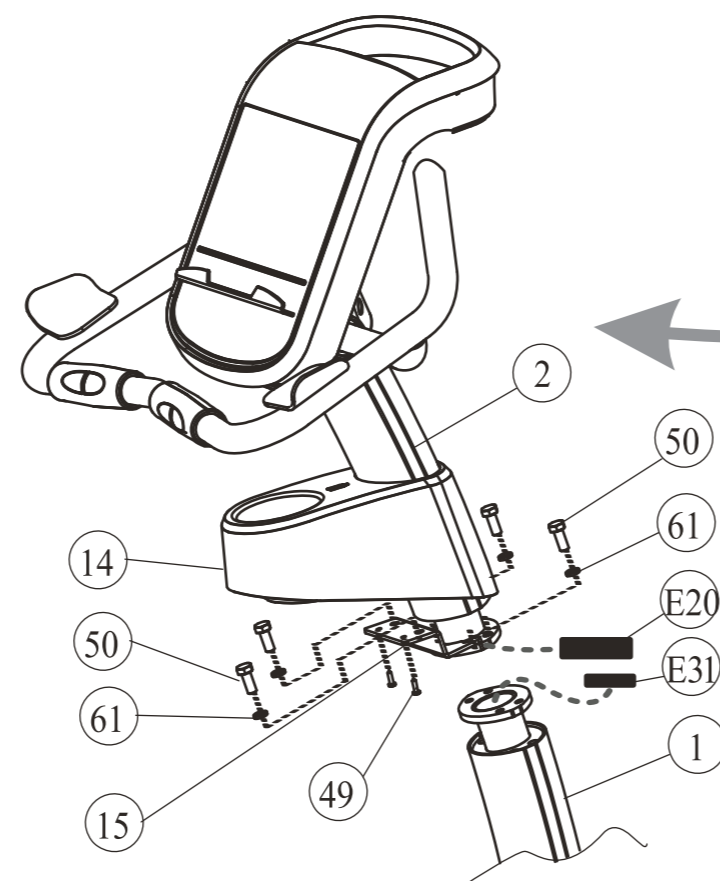

Step 3

1. Make Upper Harness (#E20) through Upright (#2).
2. Fixing Upright (#2) to Handle (#6) using:
four Φ 9* Φ 16*1.6 Washer (#22)
four Φ 8 Spring Washer (#62)
two M8*55 Socket Head Shoulder Screw (#66)
two M8*20 Socket Head Shoulder Screw (#67)
3. Fixing Front Scarf (#E8) and Rear Scarf (#E9) to Handle (#6) using:
two ST2.9*16 Screw (#49)