

# FORCE USA

## ORIGINAL LEG PRESS HACK SQUAT

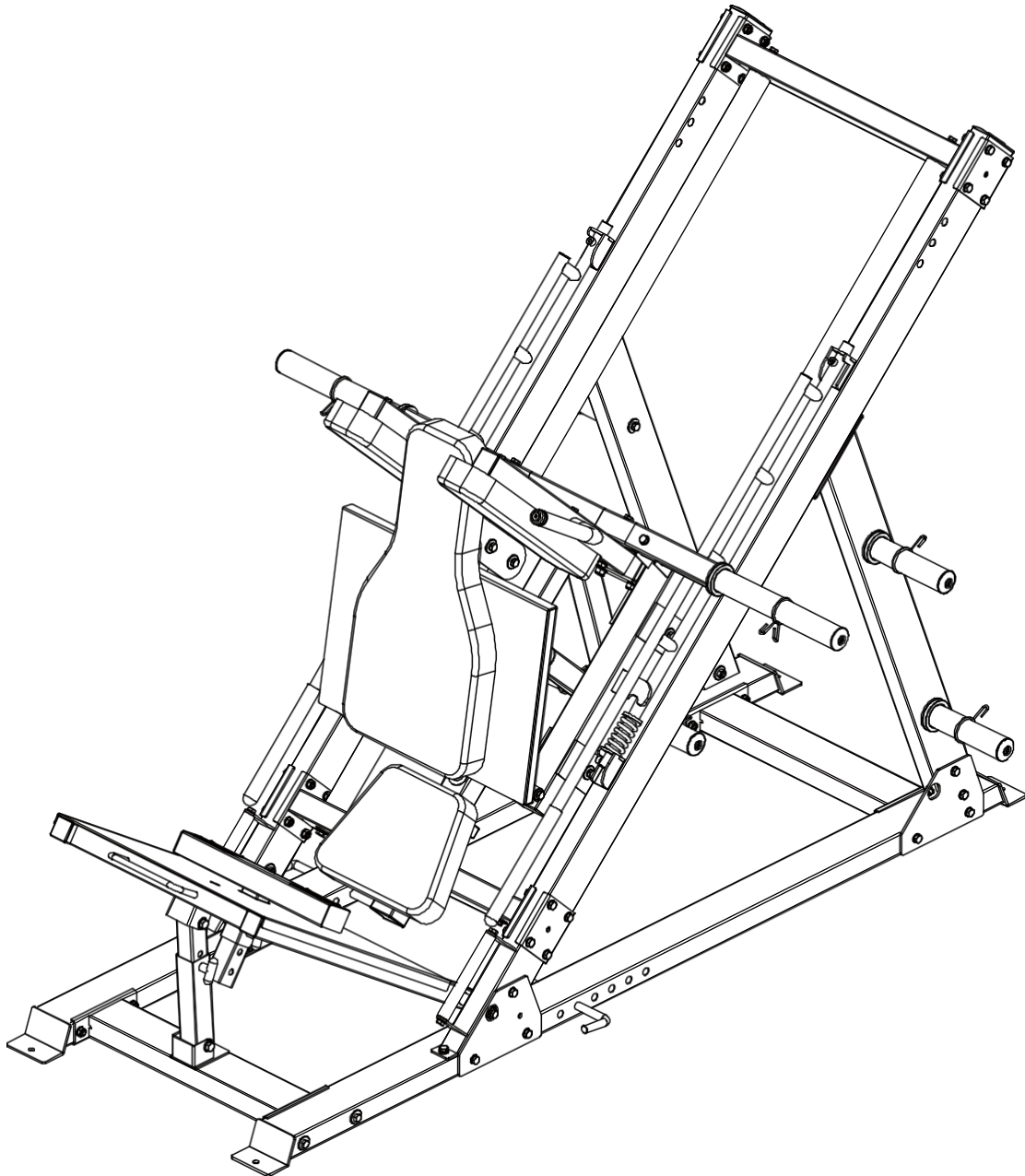

OWNER'S MANUAL | F-MLPHS-V2

# CONTENTS

List of parts	2-5
Installation step 1	6-7
Installation step 2	8-10
Assembly step 3	11-14
Installation step 4	15-18
Assembly step 5	19-22
Installation step 6	23-24
Installation step 7	25-27

# ZOZNA M

KEY NUMBER	DESCRIPTION PARTICLEQUALITY	OVÉ
1	Grounding pipe on the right	1
2	Ground Link Pipe	1
3	Front grounding tube	1
4	Large flat washer $\phi 30 \times \phi 10 \times 3$	48
5	Flat washer $\phi 10$	86
6	Locking nut M10	46
7	Hexagon bolt M10*120	12
8	Earth pipe - left	1
9	Fixing plate	4
10	Back support tube	1
11	Back support tube - left	1
12	Hexagon bolt M10*70	30
13	Hexagon bolt M10*115	2
14	Inclined pipe Mounting part	1
15	Flexible washer $\phi 10$	38
16	Hexagon bolt M10*20	34
17	Inclined pipe - right part of the assembly	1
18	Guide rod down Fixed tube Mounting part	1
19	Fixed guide part of the pipe installation	1
20	Mounting part of the sliding bar	2
21	Mounting part of the slider frame	1
22	Mounting part of the end rail	1
23	100*130*4 Connecting plate	4
24	Hexagon bolt M10*30	8
25	External setting tube assembly of the foot press	1

# ZOZNA M

26	RIGHTfoot	1
----	-----------	---

# ZOZNA M

KEY NUMBER	DESCRIPTION PARTICLEQUALITY	OVÉ
27	Leg press adjustment assembly	1
28	Axle with internal thread $\varphi 15,9 \times 135$	2
29	Flat washer $\varphi 12$	14
30	Locking nut M12	6
31	Hexagon bolt M12*80	2
32	T-shaped pin	1
33	Part of the end frame assembly	2
34	Spring	2
35	Hexagon head screws M10*20	4
36	Mounting plate upside down Part	1
37	Mounting part of the Regulatory Fixing Pipe	1
38	Shoulder pads Frame - right mounting part	1
39	Dumbbell holder frame	1
40	Hexagon bolt M10*65	2
41	Hexagon bolt M10*115	2
42	Shoulder pads Frame - left mounting part	1
43	Hexagon bolt M12*75	4
44	Hexagon bolt M12*65	2
45	Part of the lifting frame assembly	1
46	Inner bar for dumbbells	1
47	Holder for dumbbells	2
48	Hexagon head screws M8*20	2
49	Holder for dumbbells	4
50	Spring collar	8
51	Rear pad	1

# ZOZNA M

52	FRAMEWORK pad	2
----	---------------	---

# ZOZNA M

KEY NUMBER	DESCRIPTION PARTICLEQUALITY	OVÉ
53	Flat washer $\phi 8$	8
54	Hexagon bolt M8*70	4
55	Seat pad	1
56	Hexagon bolt M8*45	4
57	Peg Band	2
58	Legs Brick frame	1
59	T-shaped pin	1
60	Large flat washer $\phi 25 \phi * 10 * 2$	8
61	Axle with internal thread $\phi 15,9 * 120$	2
62	Handle tube	2
63	Pipe plug 50*100*2	2
64	Double layer spring nut $\phi 23-M10$	2
65	Pipe plug $\phi 60 * 60 * 2$	1
66	Pipe plug $\phi 25 * 25 * 1,5$	4
67	Roller $\phi 59$	8
68	Inner axis threaded $\phi 17 * 81-M10$	8
69	Bearing 6003	16
70	Plug 50*70*2	4
71	Pull the pin	1
72	Stainless steel bar $\phi 50 * 0,8$	1
73	Pipe cover $\phi 30 * \phi 25 * 50$	1
74	Pipe plug $\phi 50 * 50 * 2$	3
75	Tube plug $\phi 45 * 45 * 2$	5
76	Handle cover $\phi 24,5 * 280$	1
77	Round plug $\phi 25 * 2$	1

# ZOZNA M

78	Pipe plug $\varnothing 52.5$	2
----	------------------------------	---



# ZOZNA M

KEY NUMBER	PART DESCRIPTION	QUALITY	OVÉ
79	φ50*345 Stainless steel pipe	φ49.5*6	2
80	φ48*344 Inner tube	φ48*1,5	2
81	End cap	φ50*φ44,8*φ25,5	2
82	Middle cap	φ70*φ44,8*φ25,5*30	2
83	Hexagon head screws	M8*20	2
84	Handle cover	φ32*310	2
85	Fixing ring	φ31,5*φ25,5	2
86	Screw with countersunk head	M10*25	2
87	Rear washer fixing plate		1
88	Screw with countersunk head	M8*20	4
89	Anti-slip film		2
90	Flat blind rivet with round head	4*10	6
91	Double layer spring nut	φ29-M10	2



Screw length gauge

# ASSEMBLY STEP

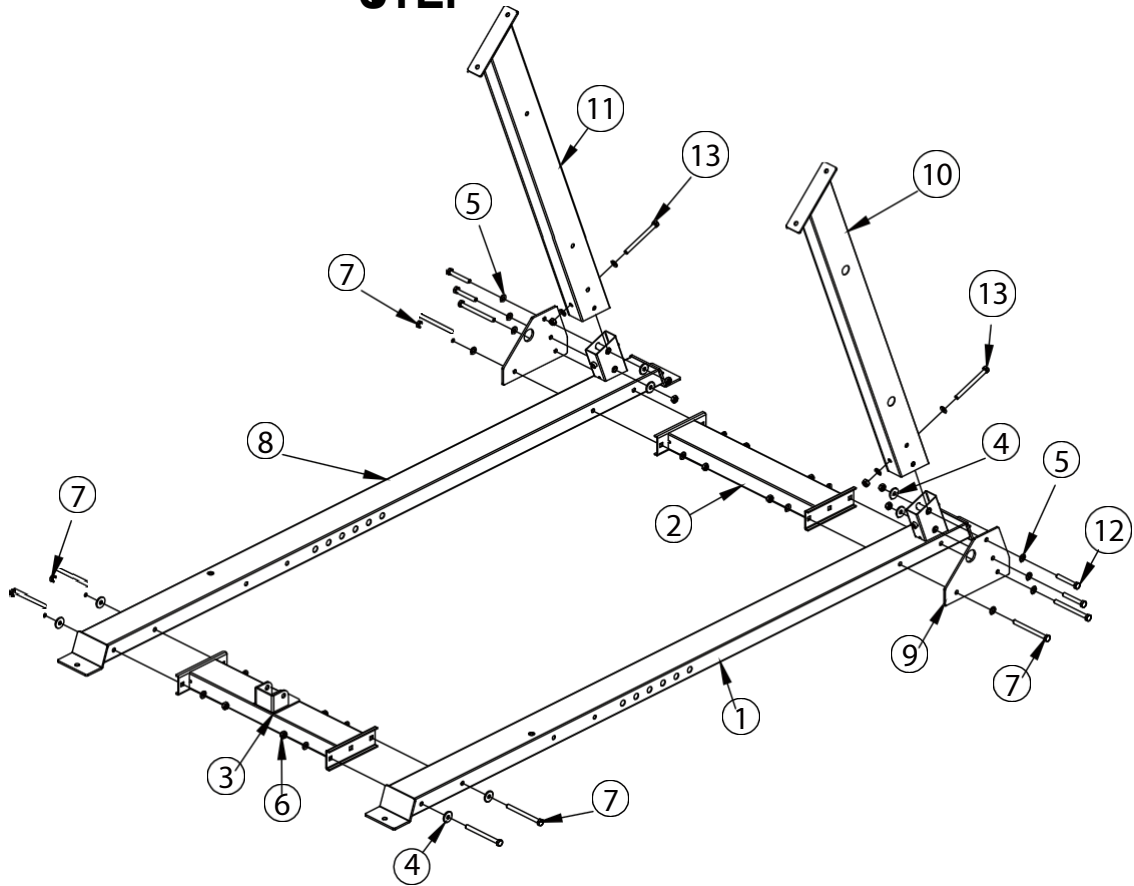

KEY NUMBER	PART DESCRIPTION	QUALITY	OVÉ
1	Grounding pipe on the right		1
2	Ground Link Pipe		1
3	Front grounding tube		1
4	Large flat washer $\phi 30 * \phi 10 * 3$		8
5	Flat washer $\phi 10$		20
6	Locking nut M10		14
7	Hexagon bolt M10*120		8
8	Earth pipe - left		1
9	Fixing plate		2
10	Back support tube		1
11	Back support tube - left		1
12	Hexagon bolt M10*70		4

# ASSEMBLY

13	<b>STEP</b> Hexagon bolt M10*115	2
----	-------------------------------------	---

# ASSEMB CHAIRING

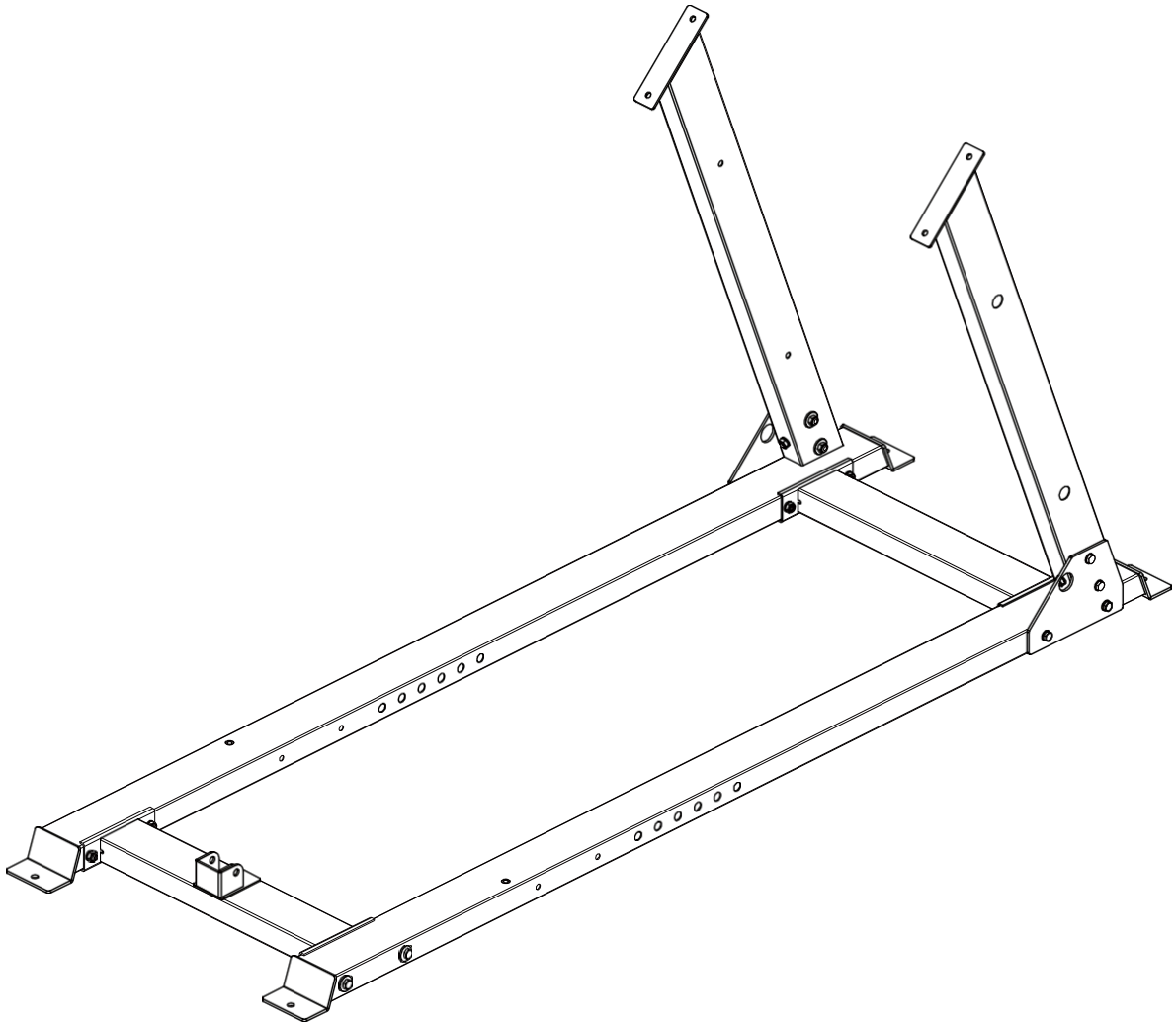

## INSTALLATION INSTRUCTIONS IN STEP 1

1. M10\*120-7 front grounding tube,  $\phi 30 \times \phi 10 \times 3$  large washer,  $\phi 10-5$  washer and M10-6 lock nut are used to connect M10\*120-7 hexagon bolt, right grounding tube 1 and left grounding tube 8.
2. The connection of ground connection-3, ground connection right-1 and ground connection left-8 uses M10\*120-7 hexagon bolt,  $\phi 30 \times \phi 10 \times 3$  large washer,  $\phi 10$  washer on washer-5 and M10 lock nut.
3. Attach the rear support pipe left-11 to the ground pipe left-8 using hexagon bolt M10\*115-13, washer  $\phi 10-5$ , lock nut M10-6 and fixing plate-9.

## ASSEMB

4. Attach the rear carrier pipe-10 to the left ground pipe-8 with a hexagonal

# ASSEMB

screws M10\*115-13, washers A10W-5, nut M10-6 and fixing plate 9.

LY

# ASSEMBLY 8STEP

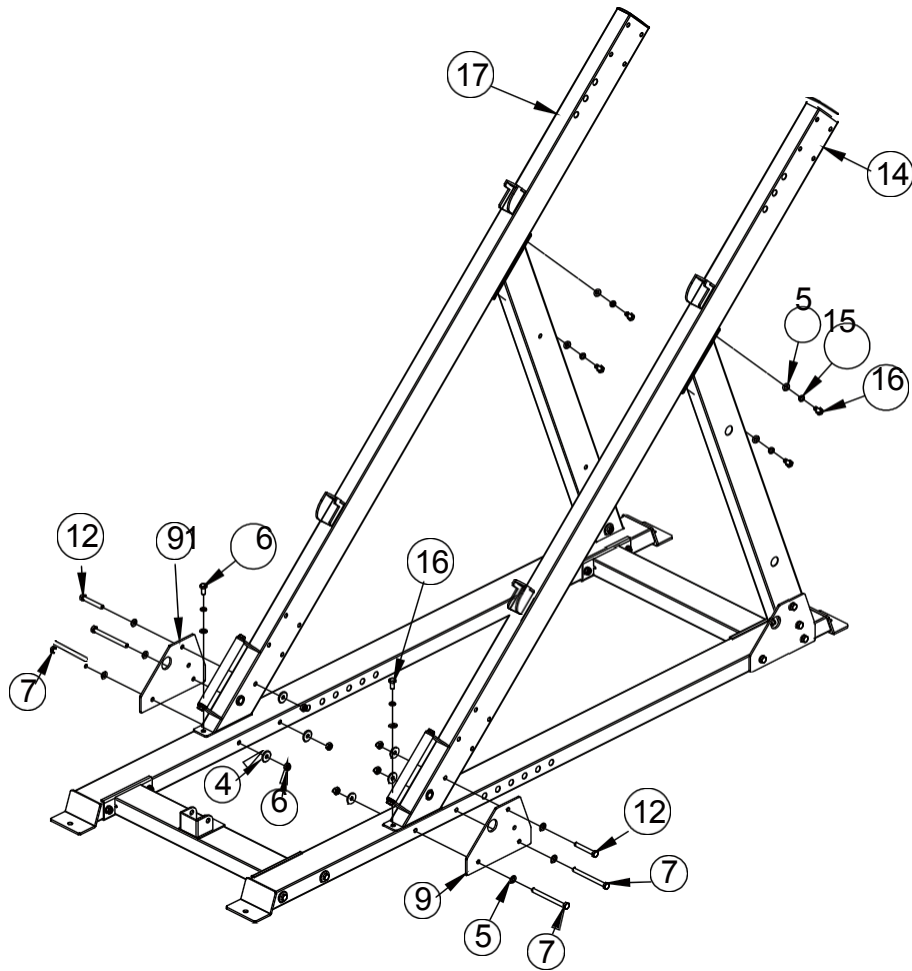

KEY NUMBER	DESCRIPTION	PARTICLEQUALITY	OVÉ
4	Large flat washer $\phi 30 \times \phi 10 \times 3$		6
5	Flat washer $\phi 10$		12
6	Locking nut M10		6
7	Hexagon bolt M10*120		4
9	Fixing plate		2
12	Hexagon bolt M10*70		2
14	Inclined pipe Mounting part		1
15	Flexible washer $\phi 10$		6
16	Hexagon bolt M10*20		6
17	Inclined pipe - right part of the assembly		1

# ASSEMBLY DRAWING

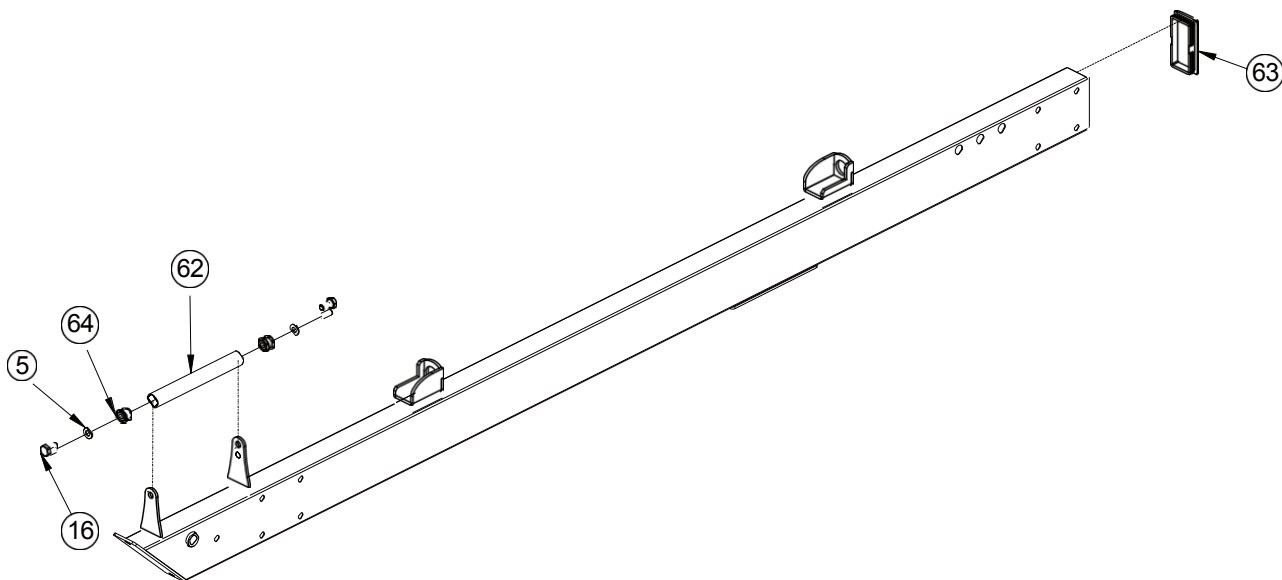

KEY NUMBER	PART DESCRIPTION	QUALITY	OVÉ
5	Flat washer $\phi 10$		2
16	Hexagon bolt M10*20		2
62	Handle tube		1
63	Pipe plug 50*100*2		1
91	Double layer spring nut $\phi 29$ -M10		2



# ASSEMBLY DRAWING

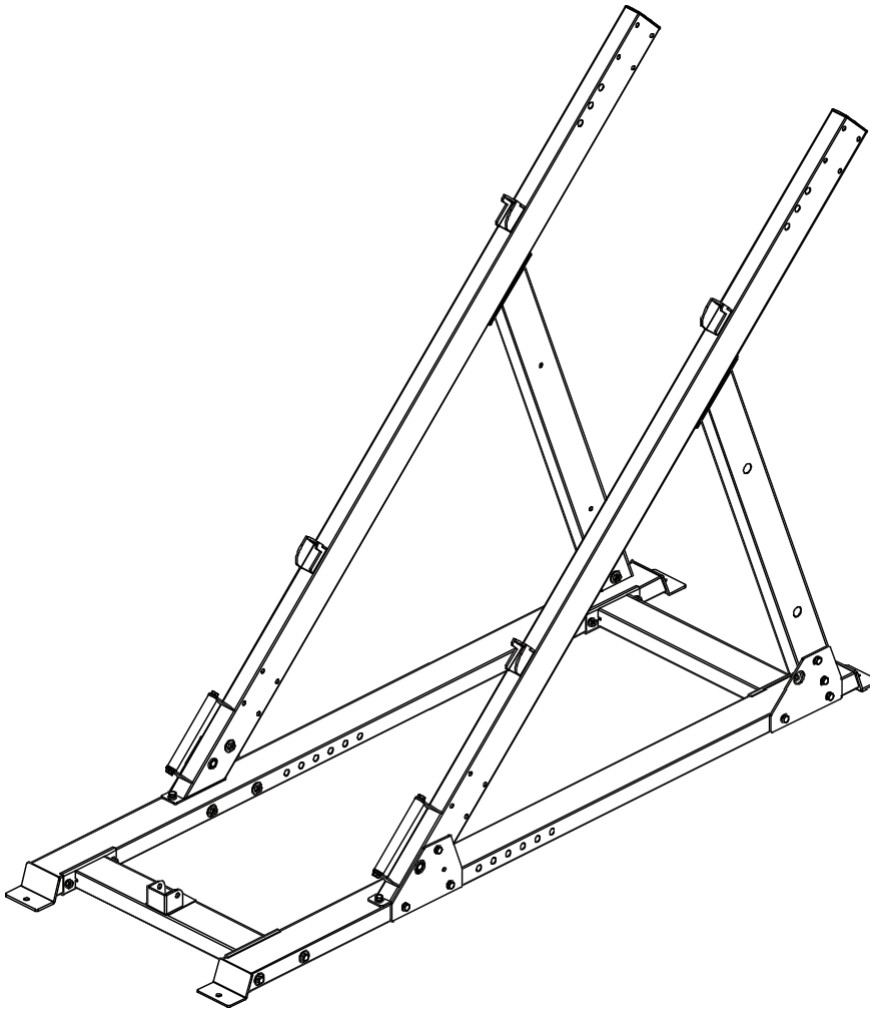

## INSTALLATION INSTRUCTIONS IN STEP 2

1. Attach the inclined pipe assembly - part 14 and the inclined pipe assembly - right part 17 to the main frame using M10\*120-7 hex bolt, large flat washer  $\phi 30 * \phi 10 * 3-4$ , flat washer  $\phi 10-5$  and M10 bolt. lock nut-6, fixing plate-9, hexagon bolt M10\*20-16 and flexible washer  $\phi 10-15$ .

## ASSEMBLY STEP

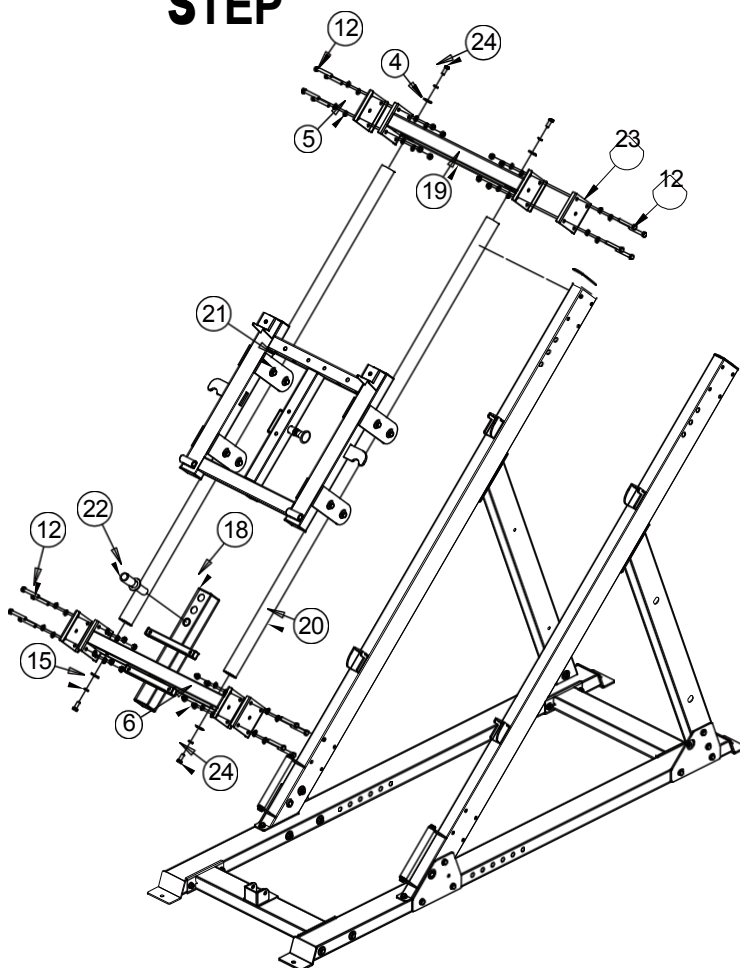

KEY NUMBER	DESCRIPTION	PARTICLEQUALITY	OVÉ
4	Large flat washer $\phi 30 \times \phi 10 \times 3$		4
5	Flat washer $\phi 10$		32
6	Locking nut M10		16
12	Hexagon bolt M10*70		16
15	Flexible washer $\phi 10$		4
18	Guide rod down Fixed tube Mounting part		1
19	Fixed guide part of the pipe installation		1
20	Mounting part of the sliding bar		2
21	Mounting part of the slider frame		1
22	Mounting part of the end rail		1
23	100*130*4 Connecting plate		4

# ASSEMBLY

24	<b>STEP</b> Hexagon bolt M10*30	4
----	------------------------------------	---

# ASSEMB KRESLEN IE

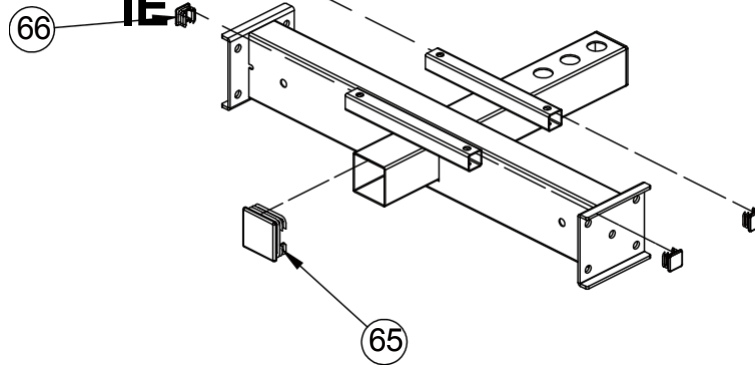

KEY NUMBER	DESCRIPTION OF THE WORK	QUALITY
65	Pipe plug $\phi 60 \times 60 \times 2$	1
66	Pipe plug $\phi 25 \times 25 \times 1,5$	4

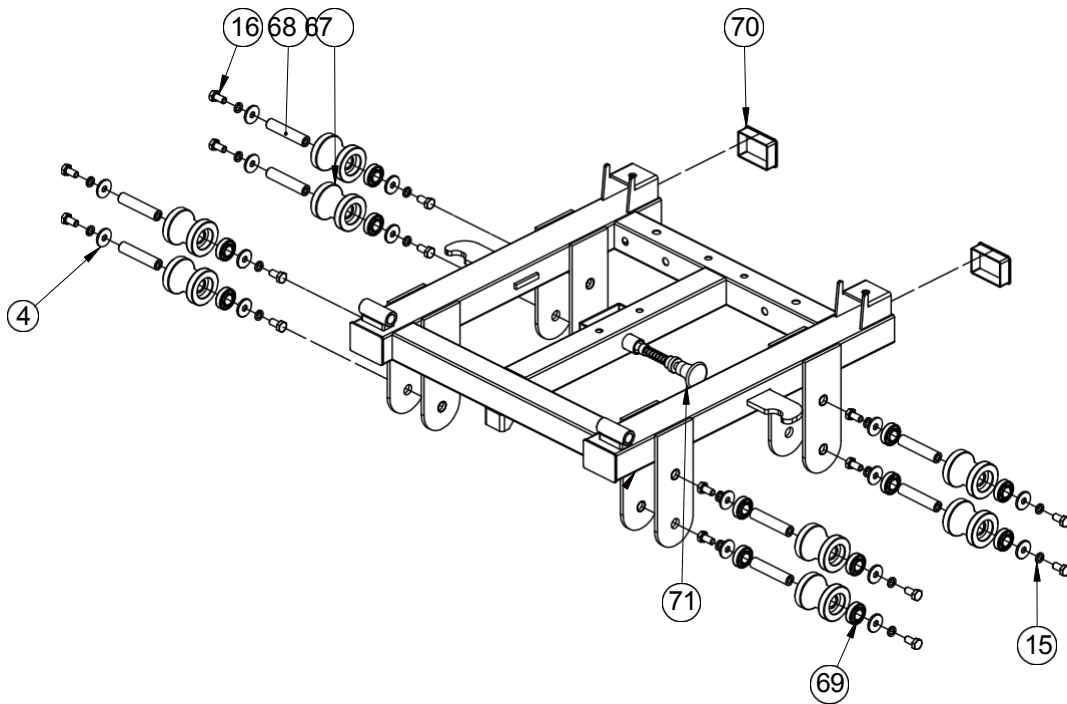

KEY NUMBER	DESCRIPTION OF THE WORK	QUALITY
4	Large flat washer $\phi 30 \times \phi 10 \times 3$	16
15	Flexible washer $\phi 10$	16
16	Hexagon bolt M10*20	16
67	Roller $\phi 59$	8
68	Inner axis threaded $\phi 17 \times 81$ -M10	8
69	Bearing 6003	16
70	Plug $50 \times 70 \times 2$	2
71	Pull the pin	1

# ASSEMBLY DRAWING

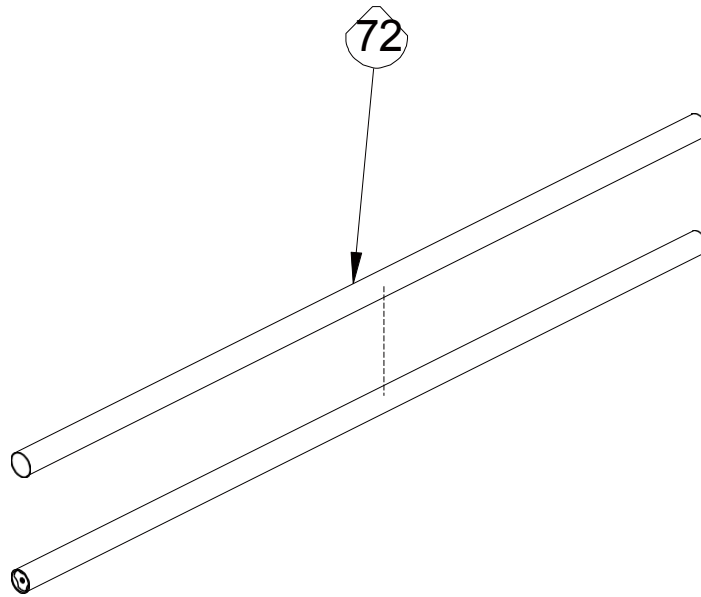

KEY NUMBER	DESCRIPTION OF THE WORK	QUALITY
72	Stainless steel bar $\phi 50 \times 0,8$	1

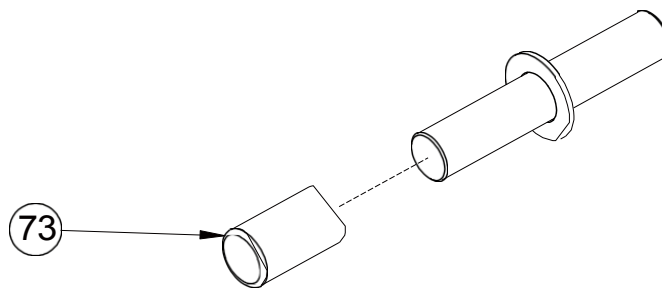

KEY NUMBER	DESCRIPTION OF THE WORK	QUALITY
73	Pipe cover $\phi 30 \times \phi 25 \times 50$	1

# ASSEMBLY DRAWING

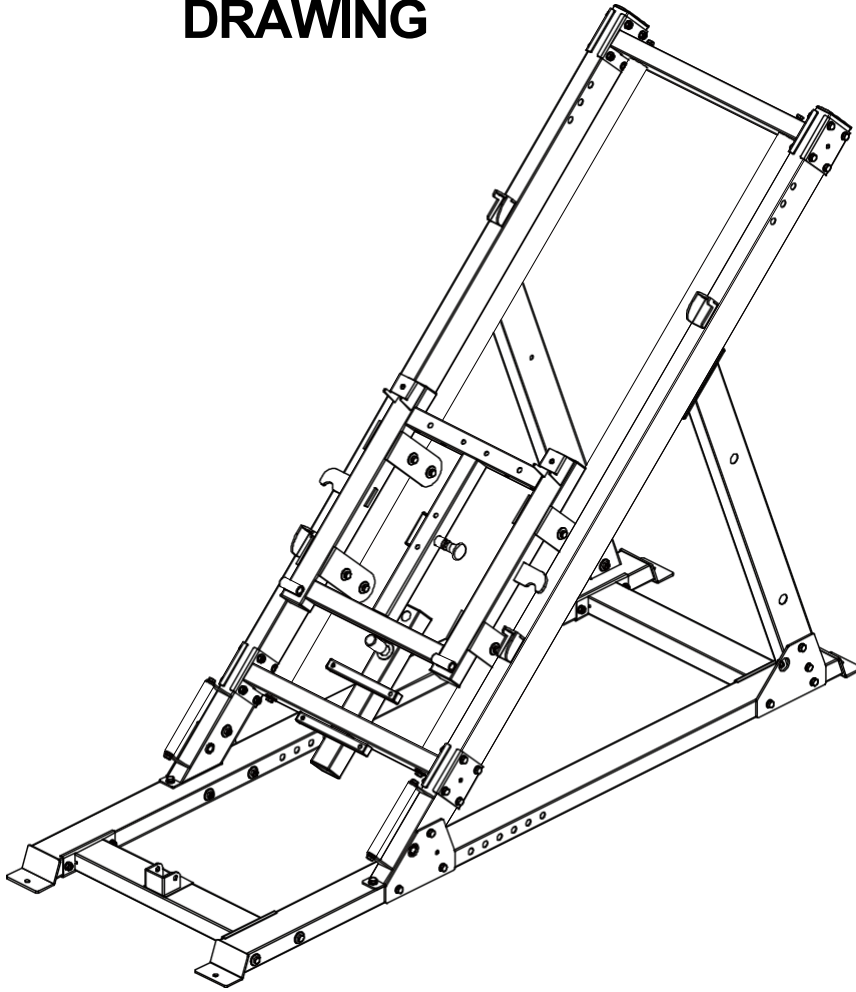

## INSTALLATION INSTRUCTIONS IN STEP 3

1. Attach the guide rod down to the fixed tube assembly part 18 to the main frame with M10\*70-12 hex bolt,  $\phi 10-5$  flat washer and M10-6 lock nut and 100\*130\*4 connection plate.
2. Attach the slide bar assembly, part 20, to the guide bar down on the fixed tube, part 18, using an M10\*30-24 hex bolt, a  $\phi 10-15$  flexible washer, and a large  $\phi 30*\phi 10*3-4$  flat washer.
3. Insert the slide frame assembly, part 21, into the slide bar assembly, part 20.
4. Attach the fixed guide bar assembly - part 19 to the main frame using M10\*70-12 hex bolt,  $\phi 10-5$  flat washer and M10-6 lock nut and 100\*130\*4 connection plate.

## ASSEMB

5. Attach the slide rail ~~part W201~~ to the fixed guide rail assembly, part 19, using an M10\*30-24 hexagon bolt, a  $\phi$ 10-15 flexible washer and a large  $\phi$ 30\* $\phi$ 10\*3-4 flat washer.

# ASSEMBLY STEP

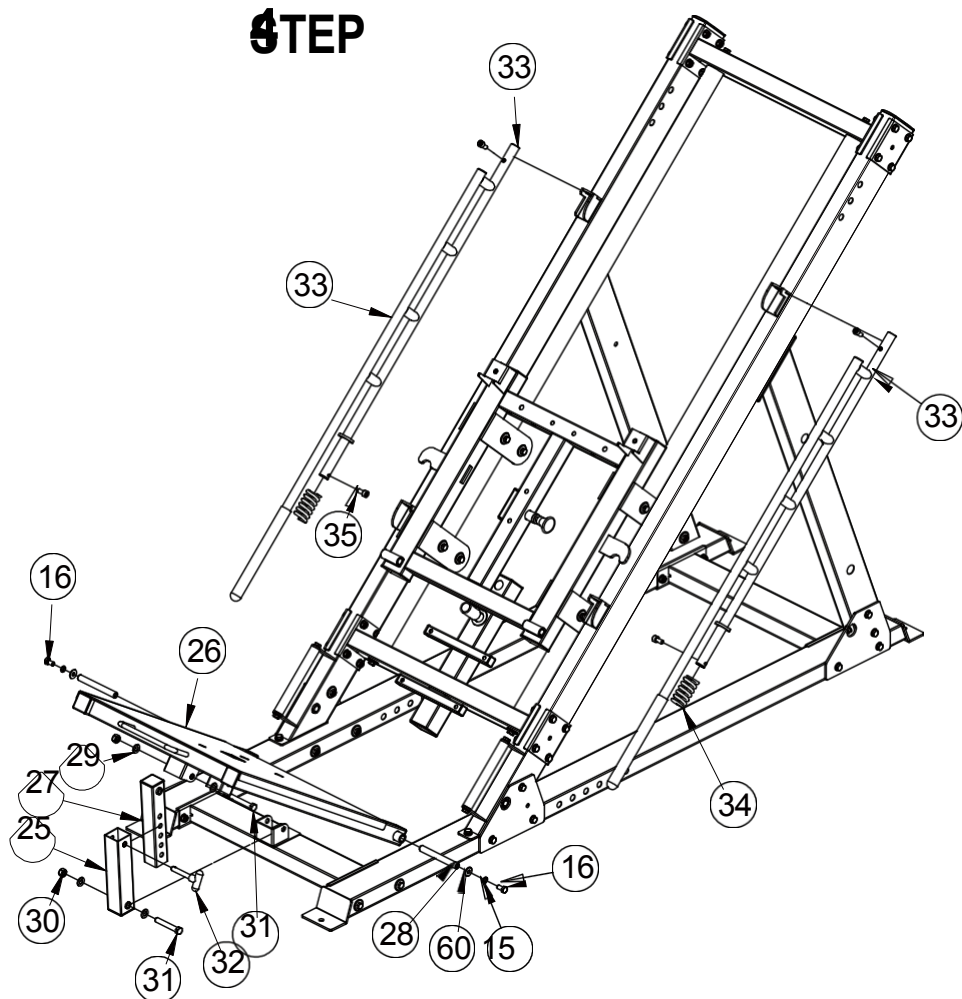

KEY NUMBER	DESCRIPTION OF THE WORK	QUALITY
15	Flexible washer $\phi 10$	4
16	Hexagon bolt M10*20	4
25	External setting tube assembly of the foot press	1
26	Footstool	1
27	Leg press adjustment assembly	1
28	Axle with internal thread $\phi 15,9 \times 135$	2
29	Flat washer $\phi 12$	4
30	Locking nut M12	2
31	Hexagon bolt M12*80	2
32	T-shaped pin	1
33	Part of the end frame assembly	2
34	Spring	2
35	Hexagon head screws M10*20	4
60	Large flat washer $\phi 25 \times \phi 10 \times 2$	4



# ASSEMBLY DRAWING

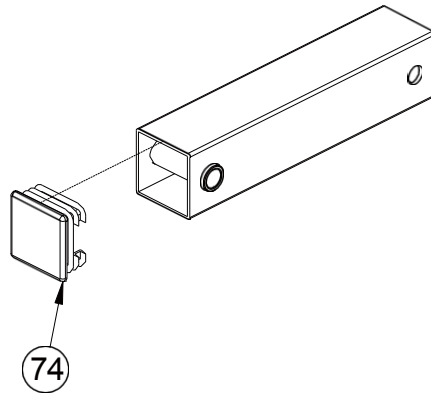

KEY NUMBER	DESCRIPTION OF THE WORK	QUALITY
74	74 Pipe plug $\phi 50 \times 50 \times 2$ 1	1

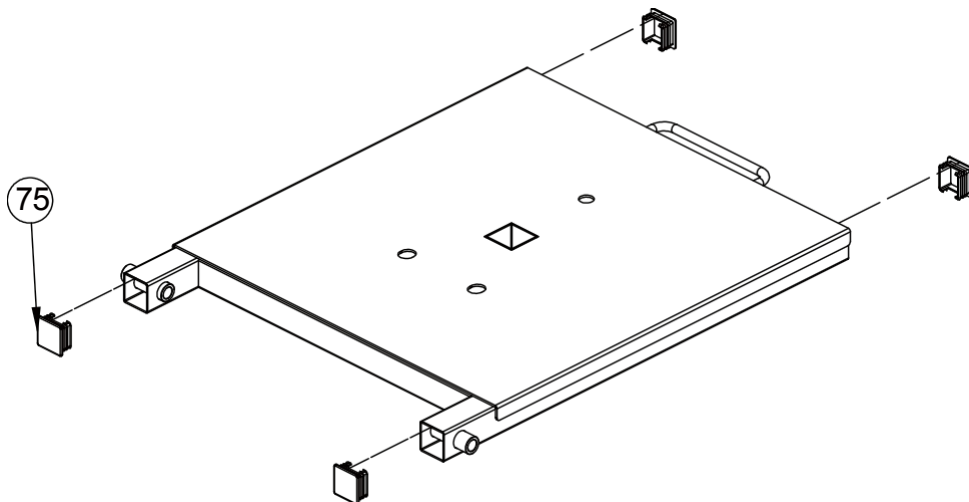

KEY NUMBER	DESCRIPTION OF THE WORK	QUALITY
75	Tube plug $\phi 45 \times 45 \times 2$	4

# ASSEMBLY DRAWING

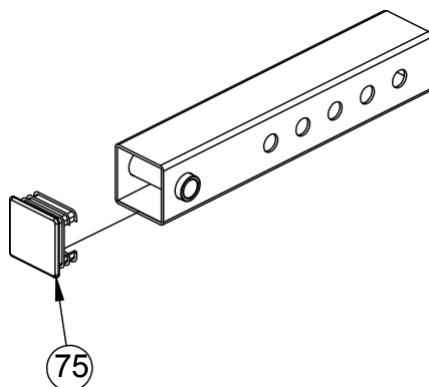

KEY NUMBER	PART DESCRIPTION	QUALITY
75	Tube plug $\phi 45 \times 45 \times 2$	4

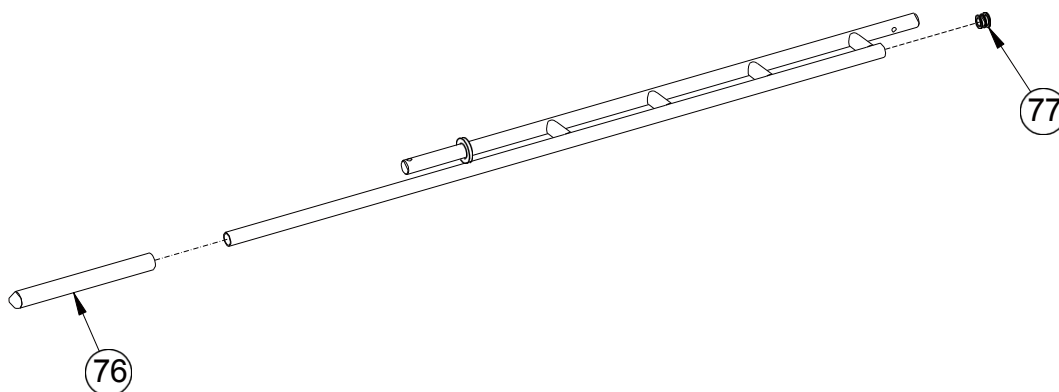

KEY NUMBER	DESCRIPTION OF THE WORK	QUALITY
76	Handle cover $\phi 24,5 \times 280$	1

**ASSEMBL  
Y**

77	<b>DRAWING</b> plug $\phi 25 \times 2$	1
----	--	---

# ASSEMBLY DRAWING

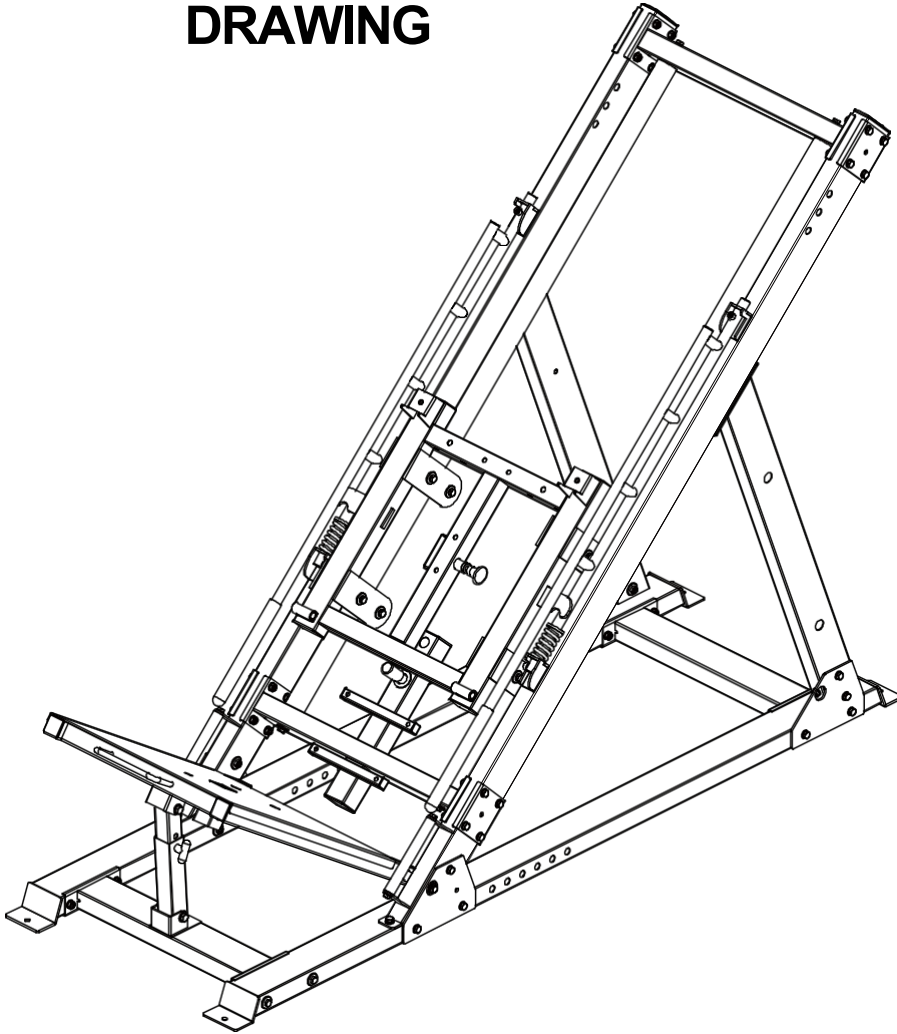

## INSTALLATION INSTRUCTIONS IN STEP 4

1. Attach the end frame assembly, part 33, to the main frame using spring 34 and M10\*20-35 hex head screws.
2. Attach the leg press outer tube assembly - part 25 to the main frame using M12\*80 hex bolt - 31, flat washer  $\phi 12$  - 29, lock nut M12 - 30.
3. Attach the leg press adjusting tube assembly - part 27 to the leg plate - 26 using hexagon bolt M12\*80 - 31,  $\phi 12$  flat washer-29, lock nut M12-30.
4. Attach the floor plate-26 to the main frame with M10\*20-16 hex bolt,  $\phi 10$ -15 flexible washer,  $\phi 25$ \* large flat washer  $\phi 10$ \*2-60 and  $\phi 15.9$ \*135 internal threaded axle.

## ASSEMB

5. Connect the outer tube assembly for the leg press setup from section 25 and the tube assembly for the **LY**

# ASSEMB

adjustment of the foot section of the pWrelsNs 2G7 by means of a T-32 shaped pin.

# LY

# ASSEMBLY STEP

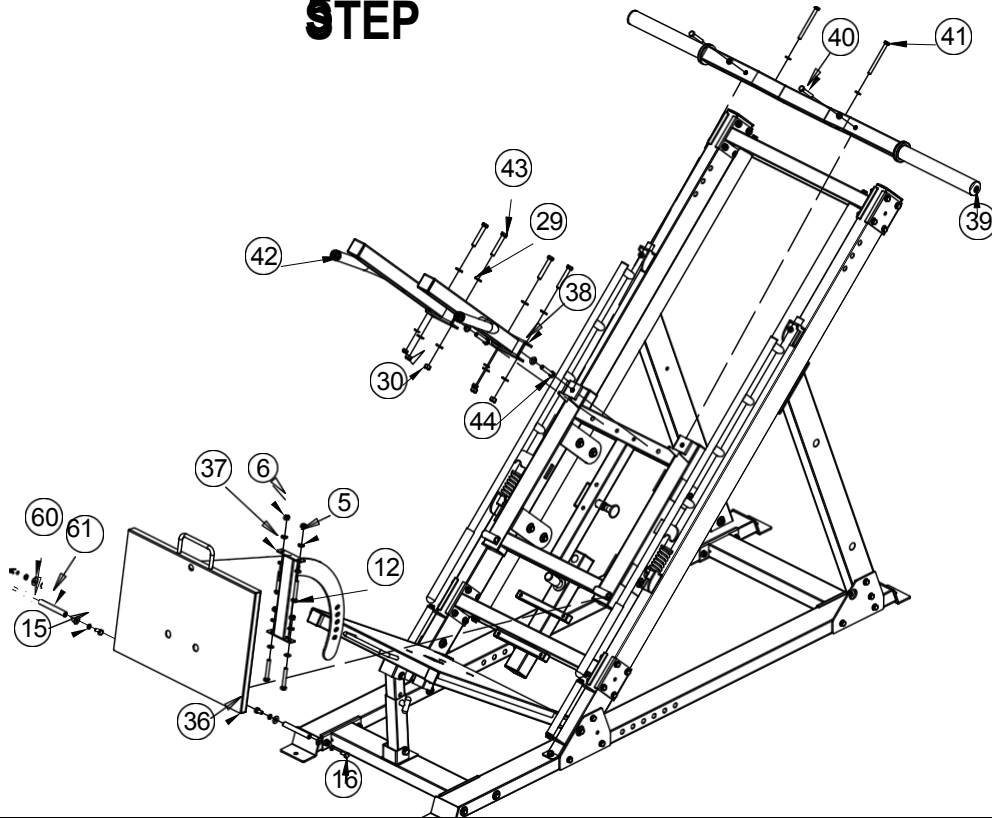

KEY NUMBER	PART DESCRIPTION	QUALITY
5	Flat washer $\phi 10$	14
6	Locking nut M10	6
12	Hexagon bolt M10*70	4
15	Flexible washer $\phi 10$	4
16	Hexagon bolt M10*20	4
29	Flat washer $\phi 12$	10
30	Locking nut M12	4
36	Mounting plate upside down Part	1
37	Mounting part of the Regulatory Fixing Pipe	1
38	Shoulder pads Frame - right mounting part	1
39	Dumbbell holder frame	1
40	Hexagon bolt M10*65	2
41	Hexagon bolt M10*115	2
42	Shoulder pads Frame - left mounting part	1
43	Hexagon bolt M12*75	4
44	Hexagon bolt M12*65	2
60	Large flat washer $\phi 25 * \phi 10 * 2$	4
61	Axle with internal thread $\phi 15,9 * 120$	2

# ASSEMBLY DRAWING

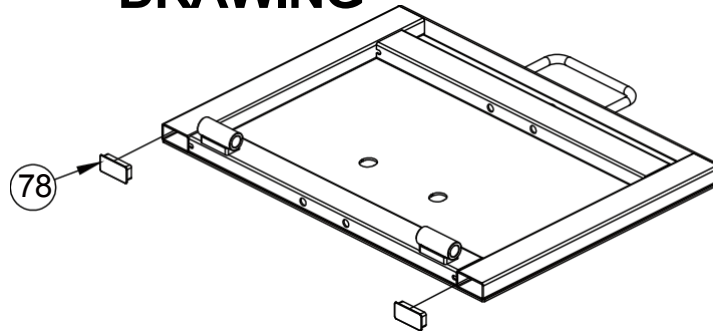

KEY NUMBER	DESCRIPTION OF THE WORK	QUALITY
78	Pipe plug $\varnothing 25 \times 25 \times 1,5$	2

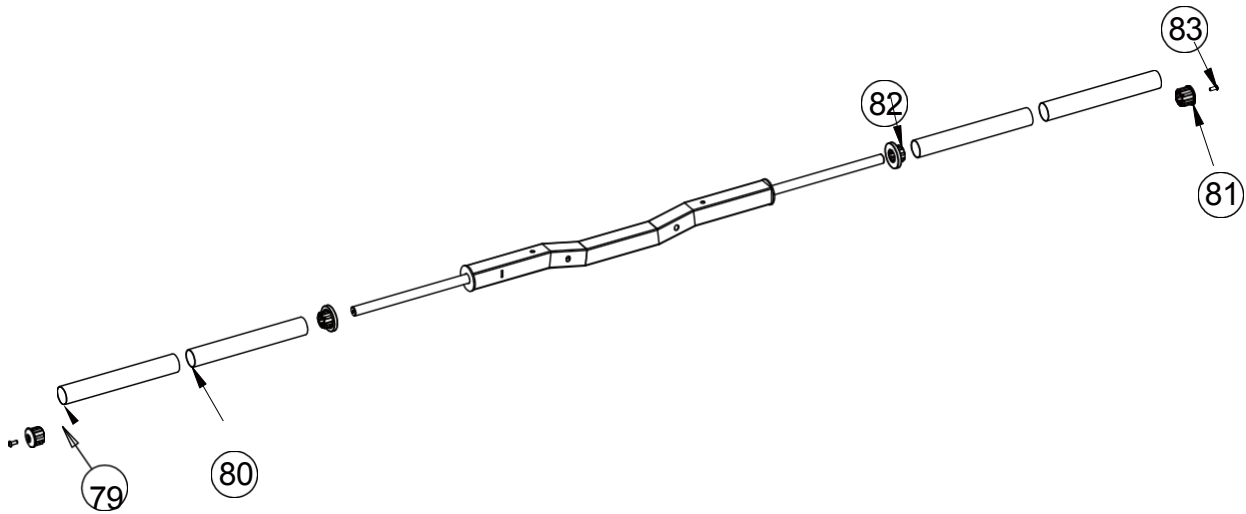

KEY NUMBER	PART DESCRIPTION	QUALITY	OVÉ
79	$\varnothing 50 \times 345$ Stainless steel pipe $\varnothing 49,5 \times 6$		2
80	$\varnothing 48 \times 344$ Inner tube $\varnothing 48 \times 1,5$		2
81	End cap $\varnothing 50 \times \varnothing 44,8 \times \varnothing 25,5$		2
82	Middle cap $\varnothing 70 \times 44,8 \times \varnothing 25,5 \times 30$		2



# ASSEMBLY

Storage Hooks Gews M8\*20

83	<b>DRAWING</b>	2
----	----------------	---

# ASSEMBLY DRAWING

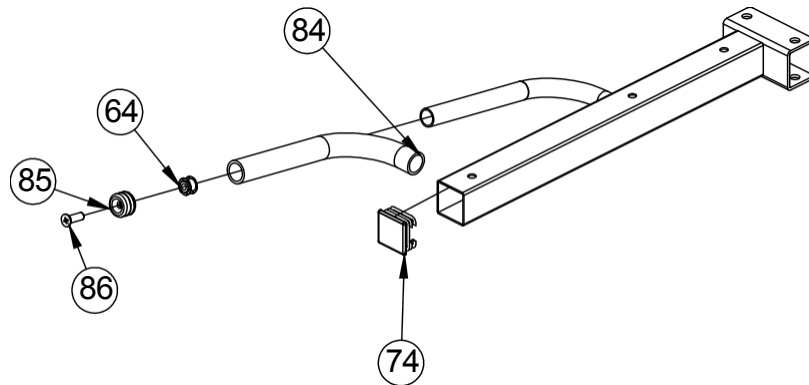

KEY NUMBER	DESCRIPTION OF THE WORK	QUALITY
64	Double layer spring nut $\phi 23\text{-M}10$	1
74	Pipe plug $\phi 50\text{*}50\text{*}2$	1
84	Handle cover $\phi 32\text{*}310$	1
85	Fixing ring $\phi 31,5\text{*}\phi 25,5$	1
86	Screw with countersunk head M10*25	1

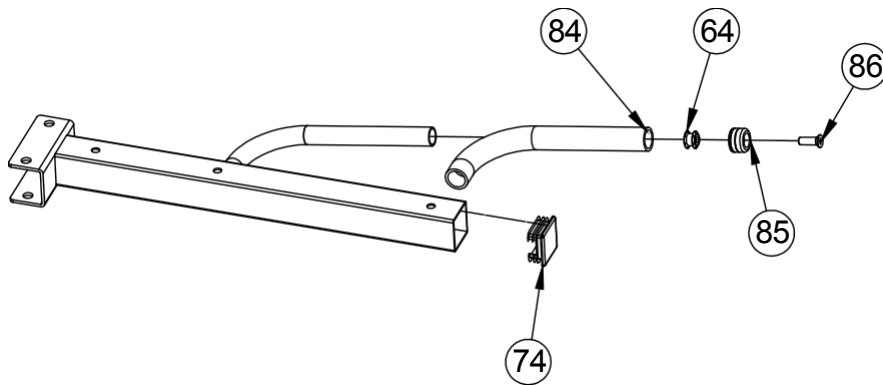

KEY NUMBER	DESCRIPTION OF THE WORK	QUALITY
64	Double layer spring nut $\phi 23\text{-M}10$	1
74	Pipe plug $\phi 50\text{*}50\text{*}2$	1
84	Handle cover $\phi 32\text{*}310$	1
85	Fixing ring $\phi 31,5\text{*}\phi 25,5$	1
86	Screw with countersunk head M10*25	1

# ASSEMBLY DRAWING

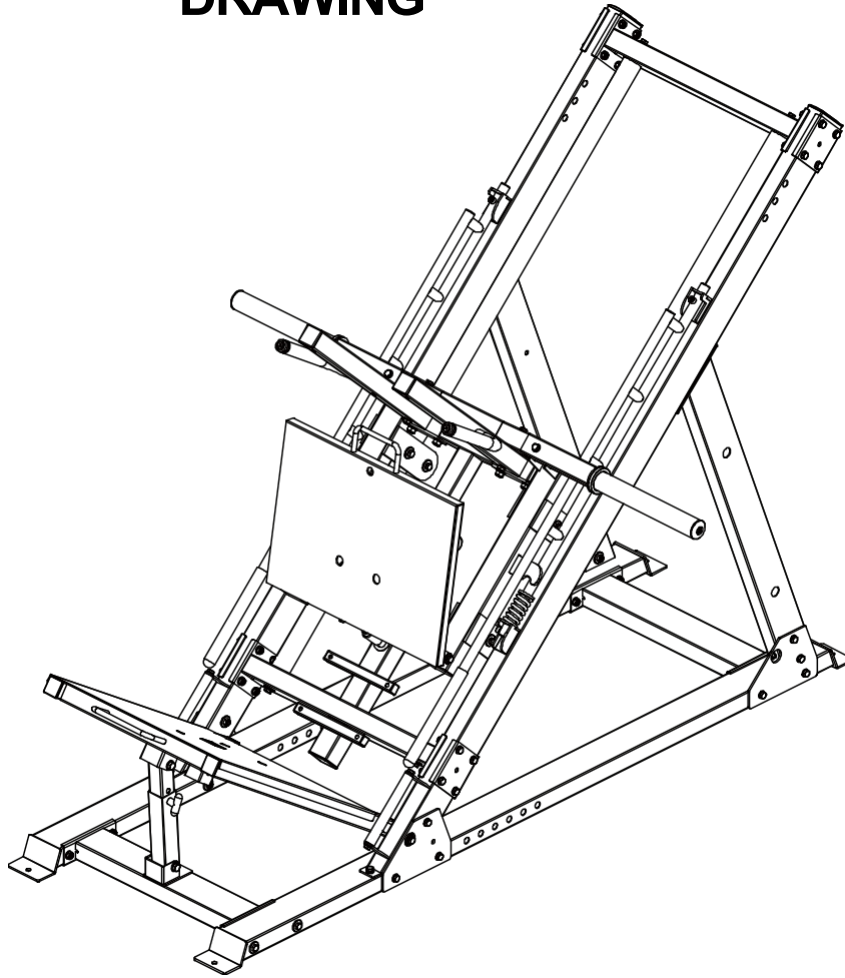

## INSTALLATION INSTRUCTIONS IN STEP 5

1. Fix the frame shoulder pads - left part of the assembly-42 and the frame shoulder pads - right part of the assembly-38 to the main frame using hexagon bolt M12\*75-43, flat washer  $\phi 12-29$ , lock nut M12-30 and hexagon bolt M12\*65-44.
2. Fix the dumbbell holder-39 frame to the main frame with M10\*65-40 hex bolt, M10\*115-41 hex bolt,  $\phi 10-5$  flat washer and M10-6 lock nut.
3. Using the hexagon bolt M10\*70-12, flat washer  $\phi 10-5$  and lock nut vM10- 6, attach the dumbbell holder frame-39 to the leg plate assembly- 36.
4. Attach the footplate mounting plate part-36 to the main frame with a hexagonal

# ASSEMB

screw M10\*20-16, flexible washer 15 Large flat washer  $\phi 25 * \phi 10 * 2-60$  and  
axles with

indoor závítφ15,900  
**ASSEMBLY CIRCUIT**

# ASSEMBLY 6STEP

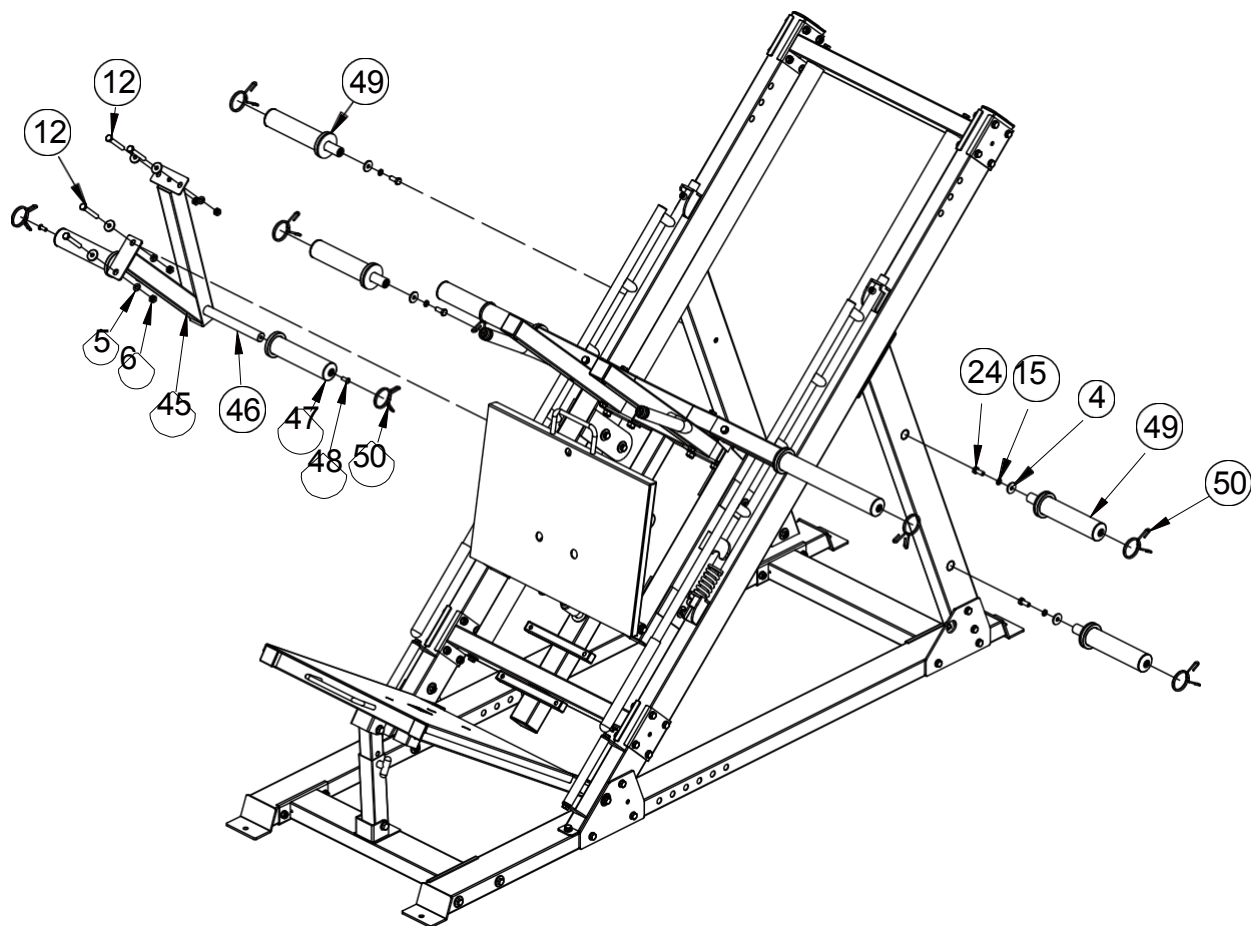

KEY NUMBER	PART DESCRIPTION	QUALITY	OVÉ
4	Large flat washer	$\phi 30 * \phi 10 * 3$	8
5	Flat washer	$\phi 10$	4
6	Locking nut	M10	4
12	Hexagon bolt	M10*70	4
15	Flexible washer	$\phi 10$	4
24	Hexagon bolt	M10*30	4
45	Part of the lifting frame assembly		1
46	Inner bar for dumbbells		1
47	Holder for dumbbells		2
48	Hexagon head screws	M8*20	2
49	Holder for dumbbells		4
50	Spring collar		8

# ASSEMB CHAIRING

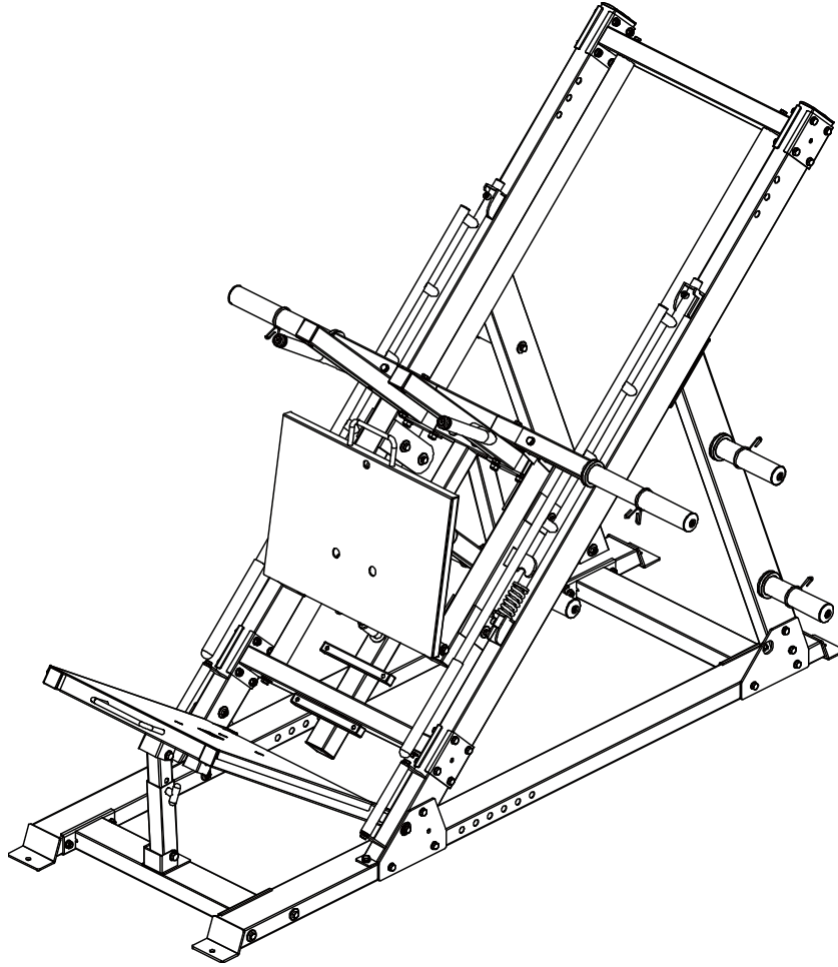

## INSTALLATION INSTRUCTIONS IN STEP 6

1. Attach the lifting frame assembly, part 45, to the frame using the M10\*70- 12 hexagon bolt, flat washer  $\phi 10-5$ , large flat washer  $\phi 30*\phi 10*3-4$  and lock nut vM10-6.
2. Attach the inner bar of the dumbbell-46 to the mounting part of the lifting frame-45 using M8\*20-48 hex head screws and the dumbbell-47 plate holder.
3. Attach the dumbbell-49 holder to the main frame with M10\*30-24 hex bolt, bolts  $\phi 10-15$  flexible washer and large flat washer  $\phi 30*\phi 10*3-4$ .
4. Fit the spring collar to the main frame.

# ASSEMBLY

## 3 STEP

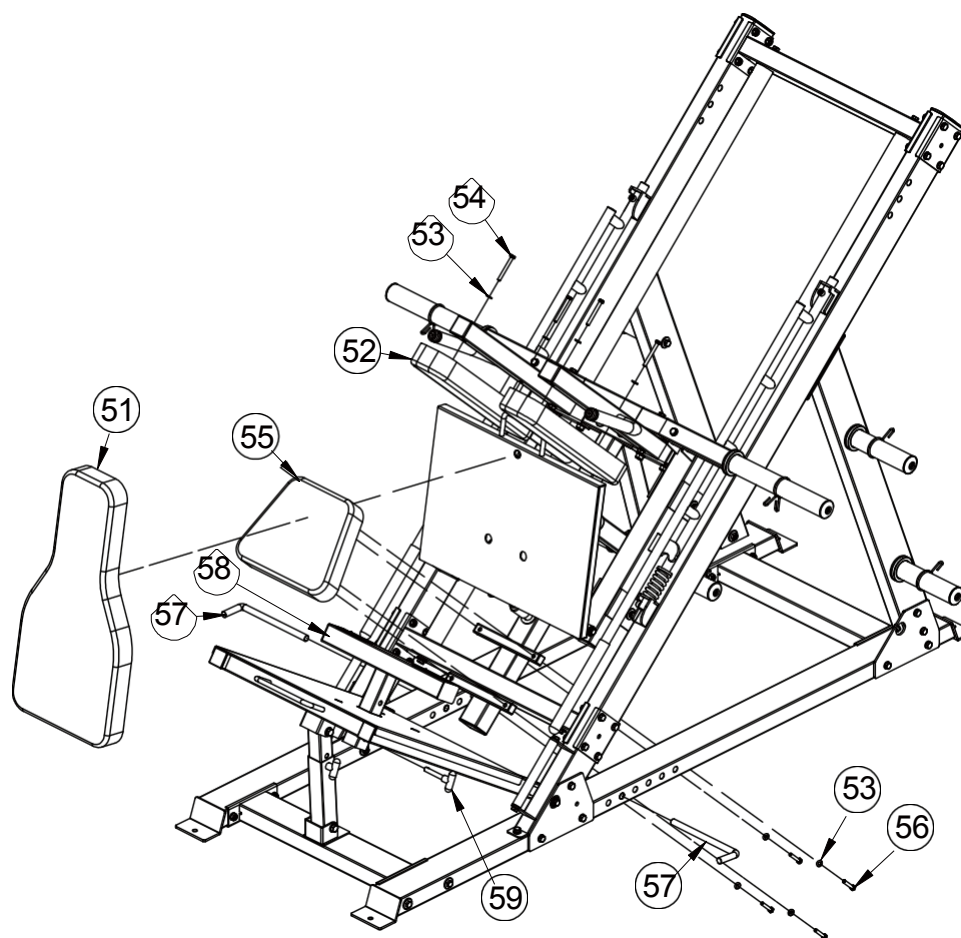

KEY NUMBER	PART DESCRIPTION	QUALITY	OVÉ
51	Rear pad		1
52	Shoulder pad		2
53	Flat washer $\varnothing 8$		8
54	Hexagon bolt M8*70		4
55	Seat pad		1
56	Hexagon bolt M8*45		4
57	Peg Band		2
58	Legs Brick frame		1
59	T-shaped pin		1



# ASSEMBLY KRESLENIE

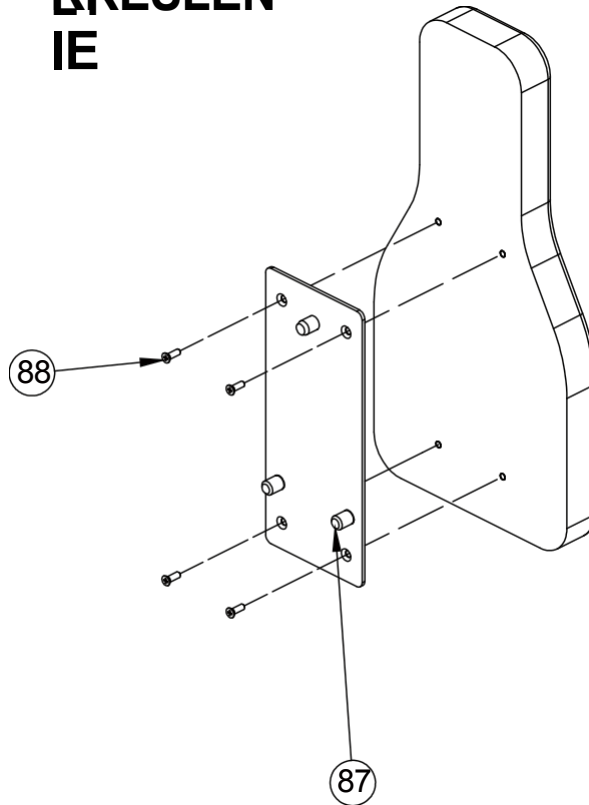

KEY NUMBER	DESCRIPTION OF THE PART	QUALITY
87	Rear washer fixing plate	1
88	Screw with countersunk head M8*20	4

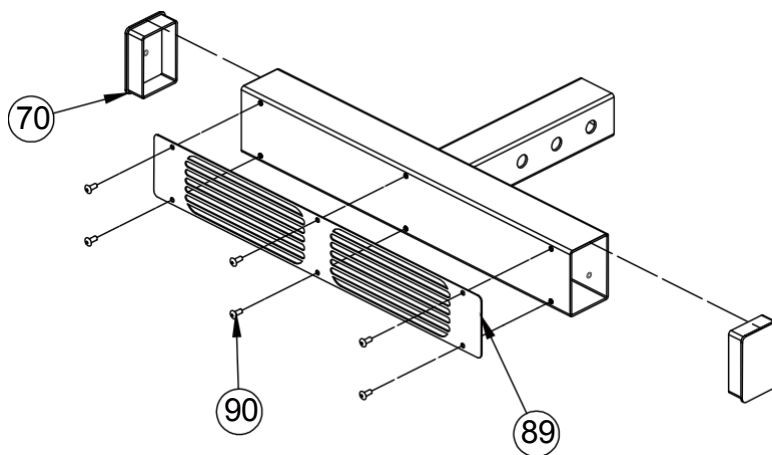

KEY NUMBER	JOB DESCRIPTION	QUALITY
70	Plug 50*70*2	2

## ASSEMB

89	<b>LY</b> Anti-slip film	2
90	FDlatRblAindWrivleNt with round head 4*10	6

# ASSEMBLY CHAIRING

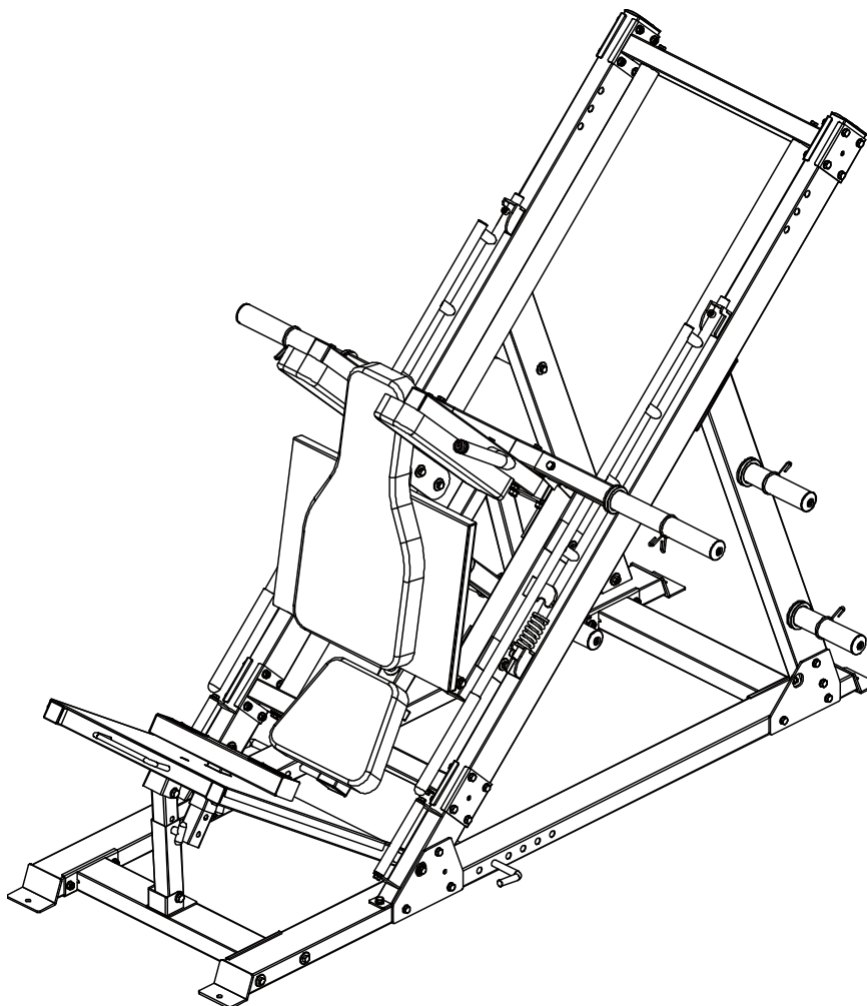

## INSTALLATION INSTRUCTIONS STEP 7

1. Attach the seat pad-55 to the main frame using the M8\*45-56 hex bolt and flat washer  $\phi$ 8-53.
2. Attach the shoulder pad-52 to the main frame using the M8\*70-54 hex bolt and flat washer  $\phi$ 8-53.
3. Place the rear washer-51 on the mounting plate with the feet of the part-36.
4. Place the foot brick-58 on the bottom foot plate-26. Use a  $\phi$ 12\*70 t-59 pin.

# ASSEMBLY

5. Attach strap pin-57 to mDaPin fAraWme.