

FORCE USA

ORIGINAL LEG PRESS HACK SQUAT

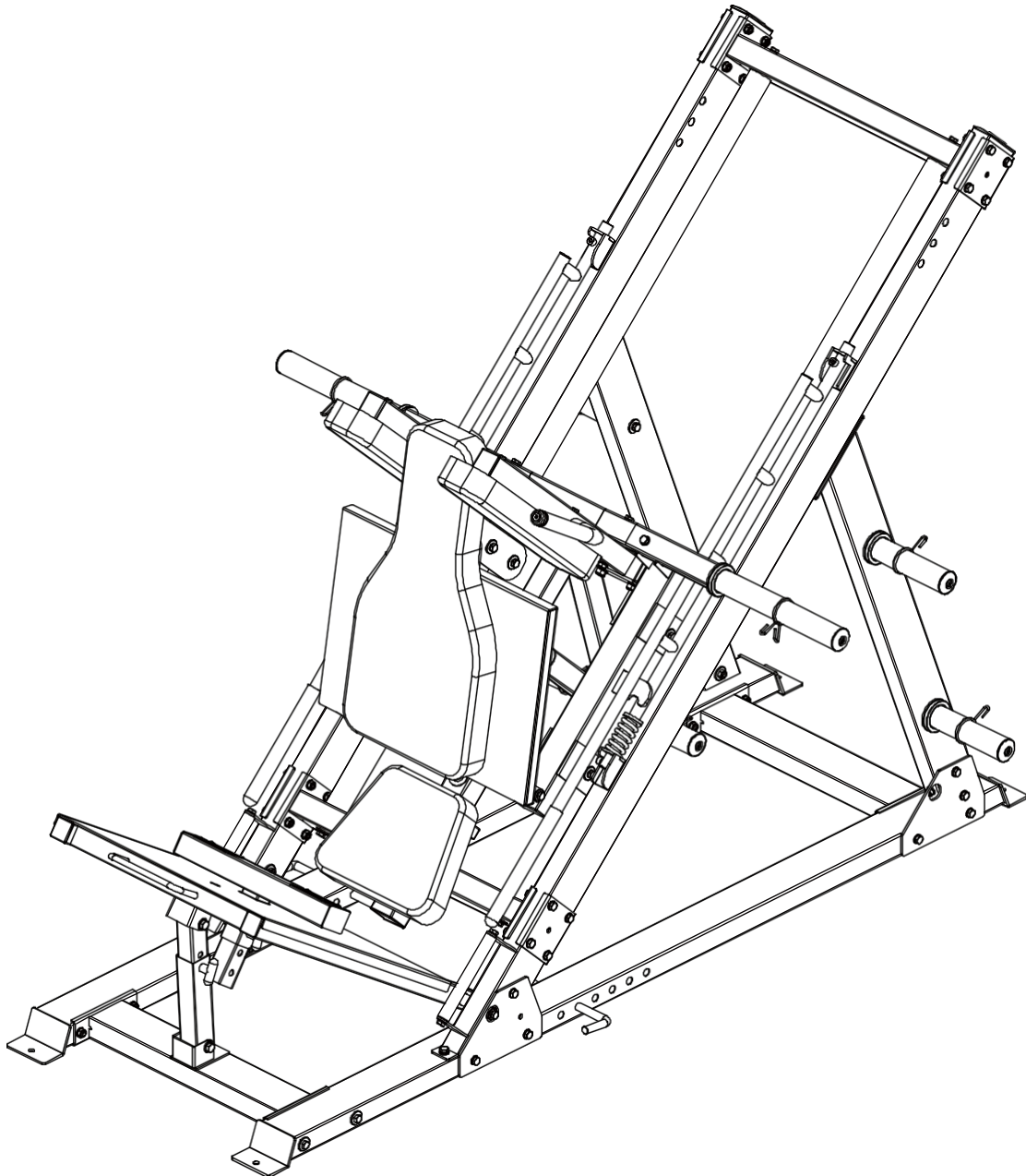

OWNER'S MANUAL | F-MLPHS-V2

CONTENTS

List of parts	2-5
Installation step 1	6-7
Installation step 2	8-10
Assembly step 3	11-14
Installation step 4	15-18
Assembly step 5	19-22
Installation step 6	23-24
Installation step 7	25-27

LIST OF

KEY ER	DESCRIPTION OF THE PARTQUALITY	NUMB
1	Grounding pipe on the right	1
2	Ground Link Pipe	1
3	Front grounding tube	1
4	Large flat washer $\phi 30 \times \phi 10 \times 3$	48
5	Flat washer $\phi 10$	86
6	Locking nut M10	46
7	Hexagon bolt M10*120	12
8	Ground pipe - left	1
9	Fixing plate	4
10	Back support tube	1
11	Back support tube - left	1
12	Hexagon bolt M10*70	30
13	Hexagon bolt M10*115	2
14	Inclined pipe Mounting part	1
15	Spring washer $\phi 10$	38
16	Hexagon bolt M10*20	34
17	Inclined pipe - right part of the assembly	1
18	Guide rod down Fixed tube Mounting part	1
19	Fixed guide pipe installation part	1
20	Mounting part of the sliding bar	2
21	Slider frame mounting part	1
22	End bar Mounting part	1
23	100*130*4 Connecting plate	4
24	Hexagon bolt M10*30	8
25	External leg press adjustment tube assembly	1

LIST OF

26	WOFRootKboSard	1
----	----------------	---

LIST OF

KEY	DESCRIPTION OF THE PART	QUANTITY	NUMBER
27	Leg press adjustment assembly	1	
28	Axle with internal thread $\phi 15,9 \times 135$	2	
29	Flat washer $\phi 12$	14	
30	Locking nut M12	6	
31	Hexagon bolt M12*80	2	
32	T-shaped pin	1	
33	Part of the limit frame assembly	2	
34	Spring	2	
35	Hexagon head screws M10*20	4	
36	Mounting plate upside down Part	1	
37	Mounting part of the Regulatory Fixing Pipe	1	
38	Shoulder pads Frame - right mounting part	1	
39	Dumbbell holder frame	1	
40	Hexagon bolt M10*65	2	
41	Hexagon bolt M10*115	2	
42	Shoulder pads Frame - left mounting part	1	
43	Hexagon bolt M12*75	4	
44	Hexagon bolt M12*65	2	
45	Part of the lifting frame assembly	1	
46	Inner bar for dumbbells	1	
47	Holder for dumbbells	2	
48	Hexagon head screws M8*20	2	
49	Holder for dumbbells	4	
50	Spring collar	8	
51	Rear pad	1	

LIST OF

52	WOShRoulKderSpad	2
----	------------------	---

LIST OF

KEY	DESCRIPTION OF THE PART	QUALITY NUMBER	QUANTITY
53	Flat washer $\phi 8$		8
54	Hexagon bolt M8*70		4
55	Seat pad		1
56	Hexagon bolt M8*45		4
57	The Peg Band		2
58	Legs Brick frame		1
59	T-shaped pin		1
60	Large flat washer $\phi 25 \phi * 10 * 2$		8
61	Axle with internal thread $\phi 15,9 * 120$		2
62	Handle tube		2
63	Pipe plug 50*100*2		2
64	Double layer spring nut $\phi 23-M10$		2
65	Tube plug $\phi 60 * 60 * 2$		1
66	Pipe plug $\phi 25 * 25 * 1,5$		4
67	Roller $\phi 59$		8
68	Internal threaded axle $\phi 17 * 81-M10$		8
69	Bearing 6003		16
70	Plug 50*70*2		4
71	Pulling pin		1
72	Stainless steel bar $\phi 50 * 0.8$		1
73	Pipe cover $\phi 30 * \phi 25 * 50$		1
74	Pipe plug $\phi 50 * 50 * 2$		3
75	Tube plug $\phi 45 * 45 * 2$		5
76	Handle cover $\phi 24,5 * 280$		1
77	Round plug $\phi 25 * 2$		1

LIST OF

78	WPipOe pRlugKφ2S5*25*1,5	2
----	--------------------------	---

LIST OF

KEY	DESCRIPTION OF THE PART	QUALITY NUMBER	QUANTITY
79	$\phi 50 \times 345$ Stainless steel pipe $\phi 49.5 \times 6$		2
80	$\phi 48 \times 344$ Inner tube $\phi 48 \times 1,5$		2
81	End cap $\phi 50 \times \phi 44,8 \times \phi 25,5$		2
82	Middle cap $\phi 70 \times \phi 44,8 \times \phi 25,5 \times 30$		2
83	Hexagon head screws M8*20		2
84	Handle cover $\phi 32 \times 310$		2
85	Fixing ring $\phi 31,5 \times \phi 25,5$		2
86	Phillips screw with countersunk head M10*25		2
87	Rear washer fixing plate		1
88	Phillips screw with countersunk head M8*20		4
89	Anti-slip sheet		2
90	Flat blind rivet with round head 4*10		6
91	Double layer spring nut $\phi 29$ -M10		2



Screw length gauge

ASSEMBLY STEP

1

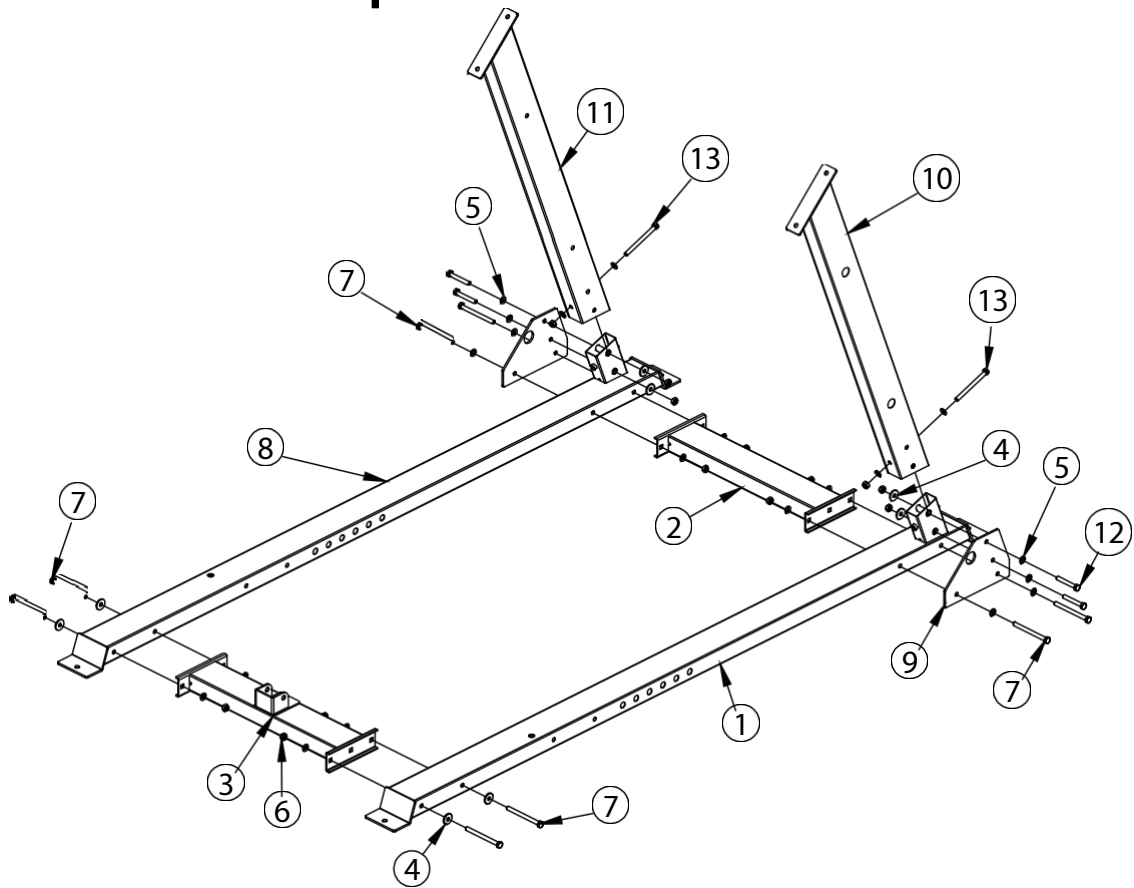

KEY	DESCRIPTION OF THE PART	QUALITY NUMBER	QUANTITY
1	Grounding pipe on the right		1
2	Ground Link Pipe		1
3	Front grounding tube		1
4	Large flat washer $\phi 30 \times \phi 10 \times 3$		8
5	Flat washer $\phi 10$		20
6	Locking nut M10		14
7	Hexagon bolt M10*120		8
8	Ground pipe - left		1
9	Fixing plate		2
10	Back support tube		1
11	Back support tube - left		1
12	Hexagon bolt M10*70		4

ASSEMBLY STEP

13	1 Hexagon bolt M10*115	2
----	-------------------------------	---

ASSEMBLY DRAWING

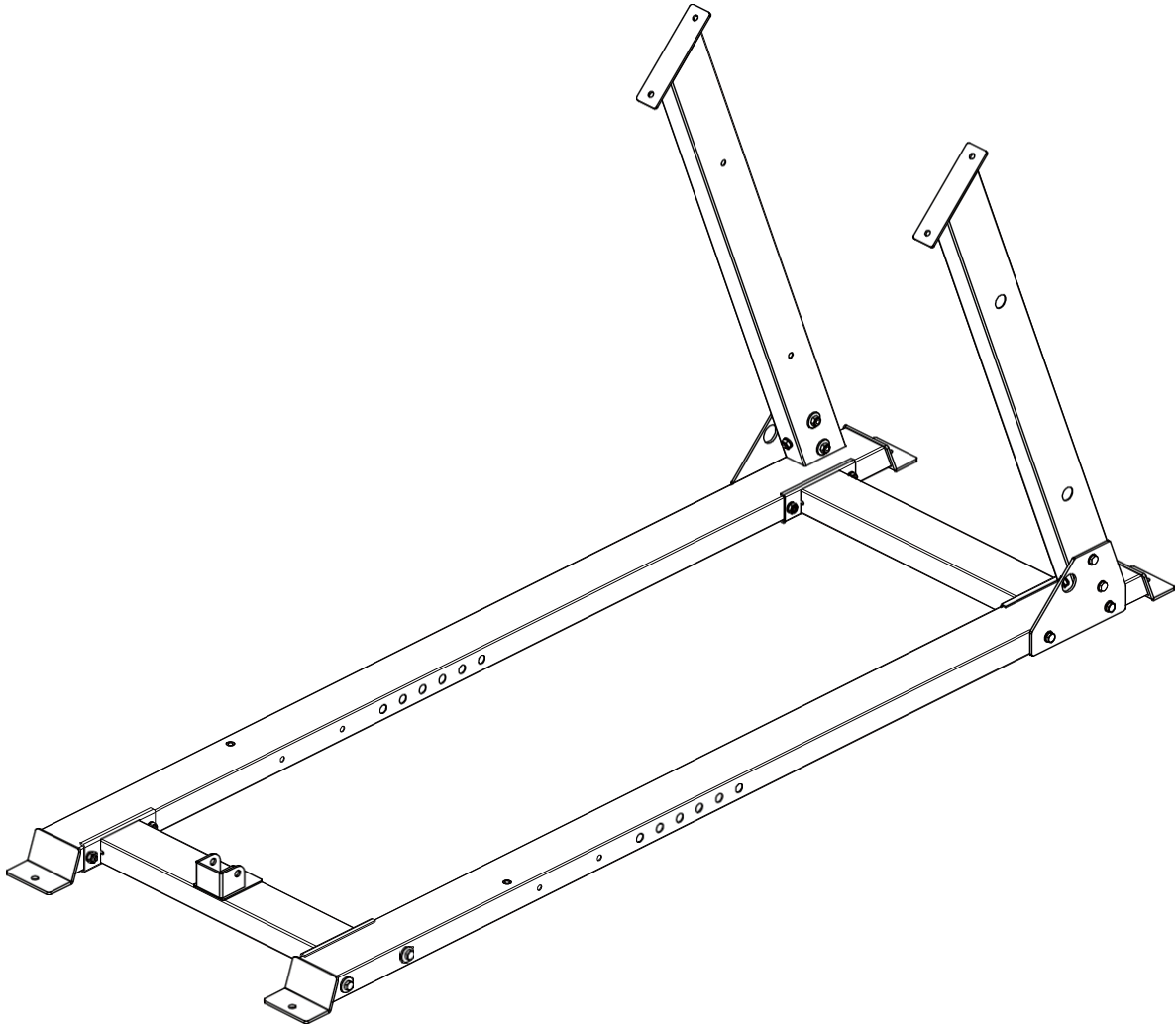

INSTALLATION INSTRUCTIONS IN STEP 1

1. The connection of front grounding tube-3, grounding tube right-1 and grounding tube left-8 use M10*120-7 hexagon bolt, $\phi 30*\phi 10*3$ large on washer-4, $\phi 10$ on washer-5 and M10-6 lock nut.
2. The connection of grounding connection pipe-3, grounding pipe right-1 and grounding pipe left-8 use M10*120-7 hexagon bolt, $\phi 30*\phi 10*3$ large at washer-4, $\phi 10$ at washer-5 and M10 lock nut.
3. Fix the rear support pipe left-11 to the ground pipe left-8 using hexagon bolt M10*115-13, washer $\phi 10$ -5, lock nut M10-6 and fixing plate-9.
4. Attach the rear carrier pipe-10 to the ground pipe left-8 with a hexagonal

ASSEMBLY

screws M10*115-13, washDerRs ϕ A10W-5, lloNckGnut M10-6 and fixing plate-9.

ASSEMBLY STEP 2

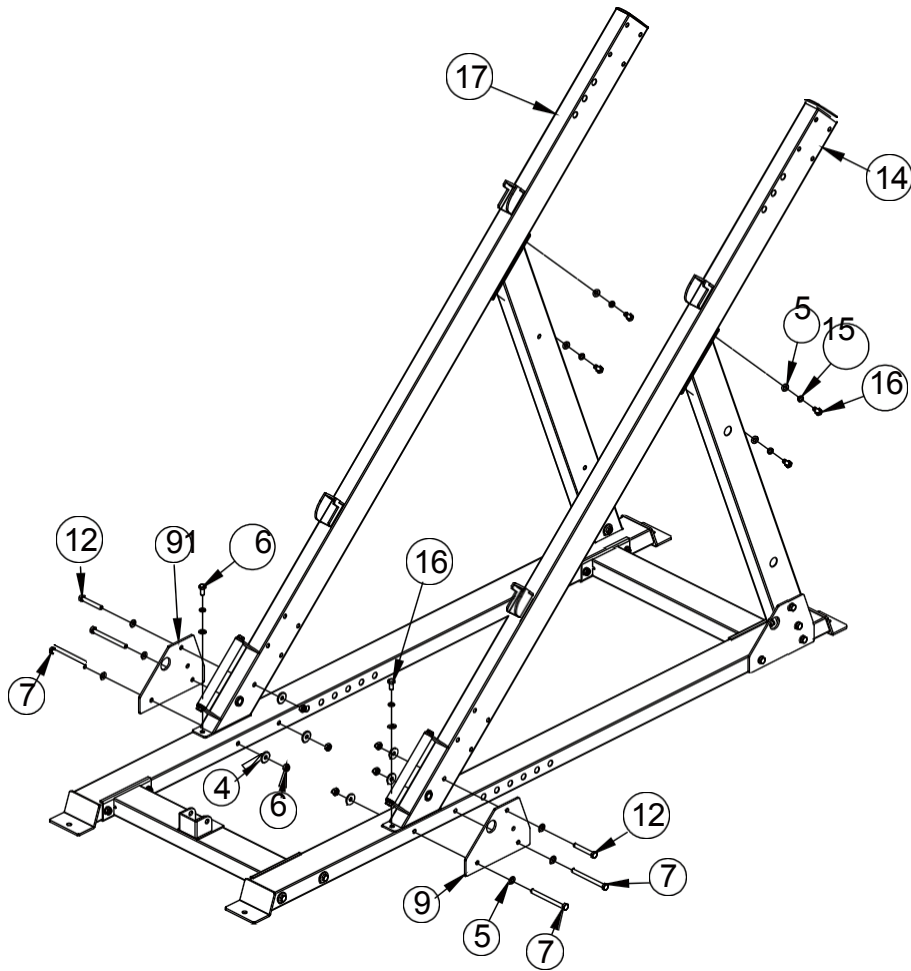

KEY ER	DESCRIPTION OF THE PARTQUALITY	NUMB
4	Large flat washer $\phi 30 * \phi 10 * 3$	6
5	Flat washer $\phi 10$	12
6	Locking nut M10	6
7	Hexagon bolt M10*120	4
9	Fixing plate	2
12	Hexagon bolt M10*70	2
14	Inclined pipe Mounting part	1
15	Spring washer $\phi 10$	6
16	Hexagon bolt M10*20	6

ASSEMBLY STEP

17	Inclin2ed pipe - right part of the assembly	1
----	---	---

ASSEMBLY DRAWING

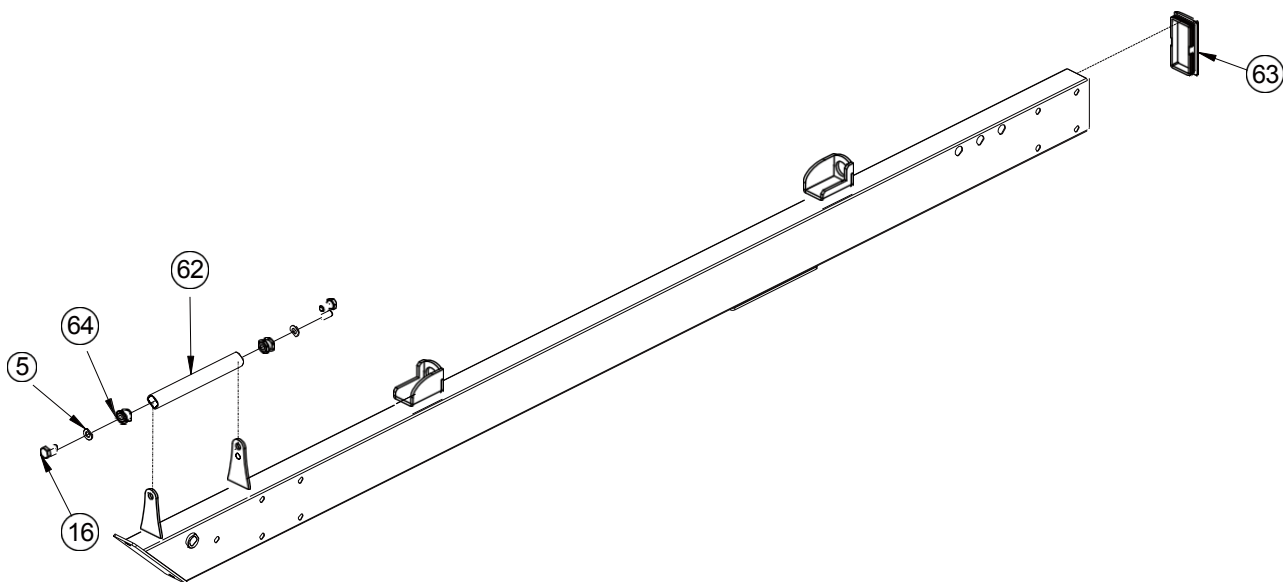

KEY	DESCRIPTION OF THE PART	QUALITY	NUMB ER
5	Flat washer $\phi 10$		2
16	Hexagon bolt M10*20		2
62	Handle tube		1
63	Tube plug 50*100*2		1
91	Double layer spring nut $\phi 29$ -M10		2

ASSEMBLY DRAWING

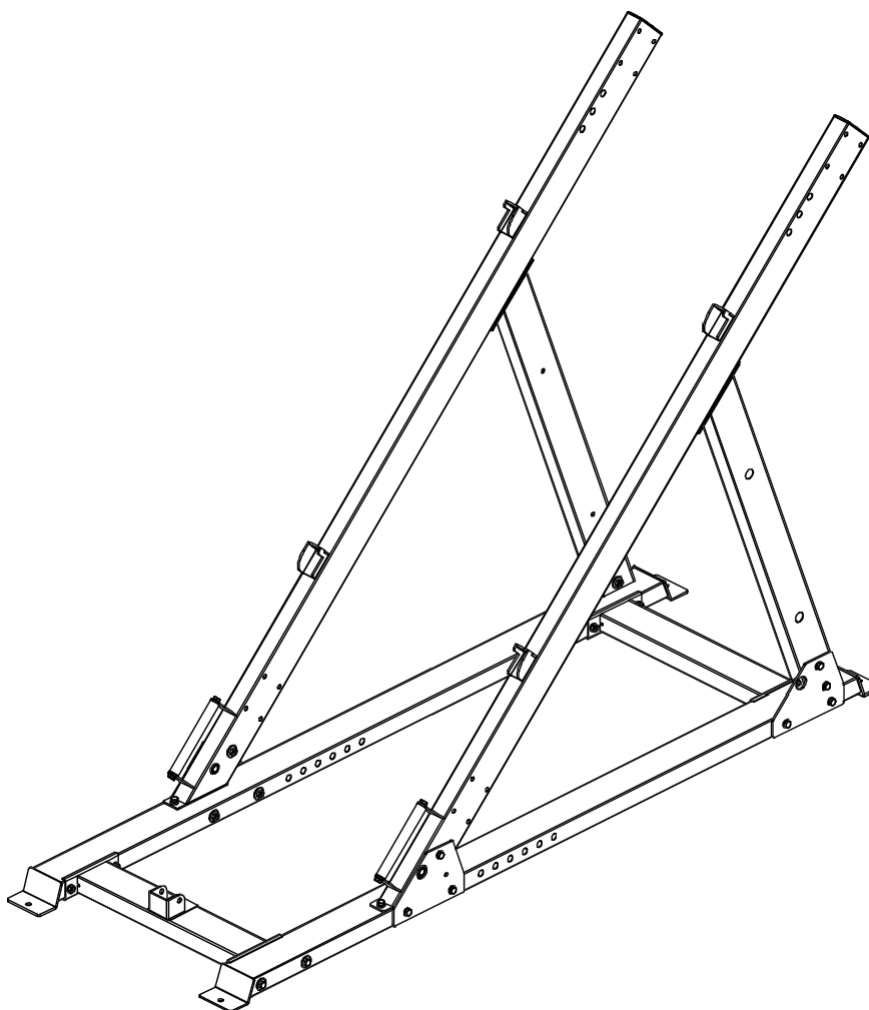

INSTALLATION INSTRUCTIONS IN STEP 2

1. Fix the inclined tube assembly - part 14 and the inclined tube assembly - right part 17 to the main frame using an M10*120-7 hexagon bolt, a large flat washer $\phi 30 * \phi 10 * 3-4$, a flat washer $\phi 10-5$ and an M10 lock nut-6, fixing plate-9, hexagon bolt M10*20-16 and flexible washer $\phi 10-15$.

ASSEMBLY STEP

3

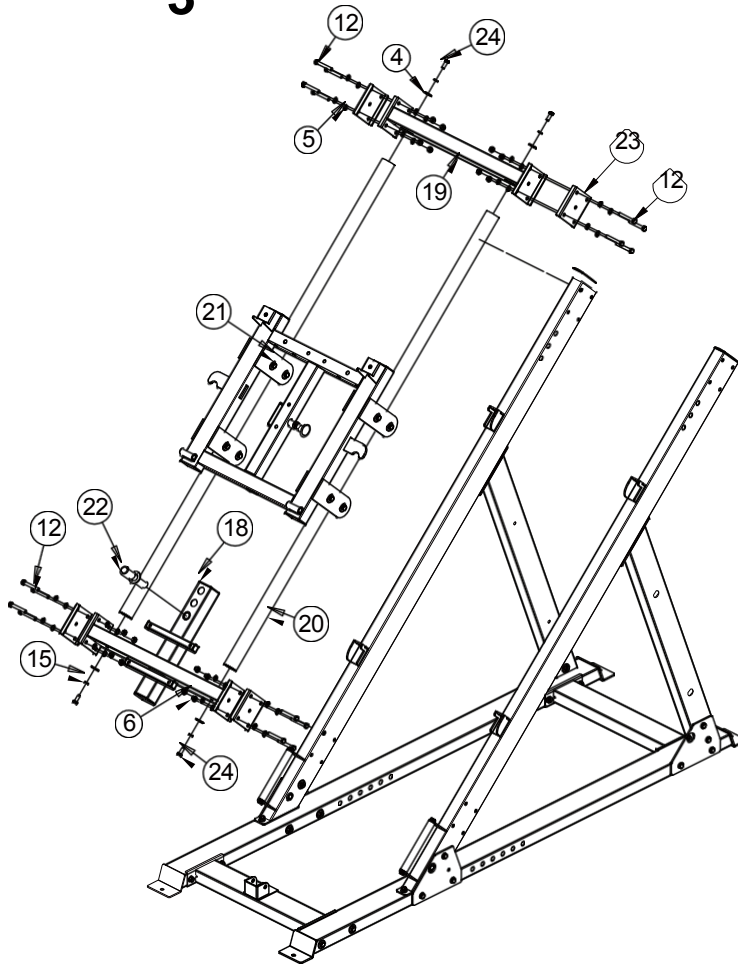

KEY ER	DESCRIPTION OF THE PARTQUALITY	NUMB
4	Large flat washer $\phi 30 \times \phi 10 \times 3$	4
5	Flat washer $\phi 10$	32
6	Locking nut M10	16
12	Hexagon bolt M10*70	16
15	Spring washer $\phi 10$	4
18	Guide rod down Fixed tube Mounting part	1
19	Fixed guide pipe installation part	1
20	Mounting part of the sliding bar	2
21	Slider frame mounting part	1
22	End bar Mounting part	1
23	100*130*4 Connecting plate	4

ASSEMBLY STEP

24	3 Hexagon bolt M10*30	4
----	------------------------------	---

ASSEMBLY DRAWING

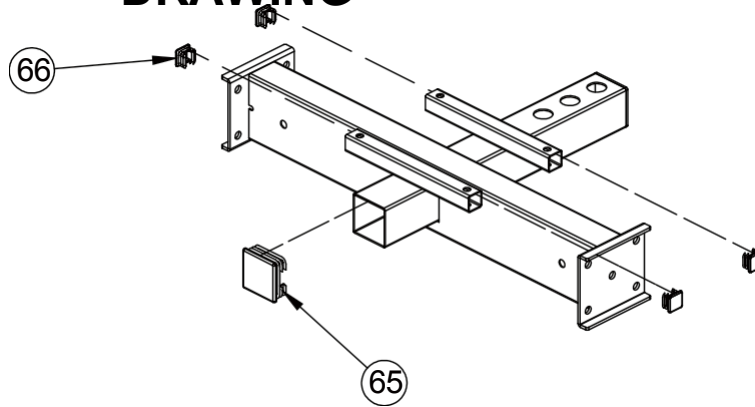

KEY NUMBER	DESCRIPTION OF THE PART	QUALITY
65	Tube plug $\phi 60 \times 60 \times 2$	1
66	Pipe plug $\phi 25 \times 25 \times 1,5$	4

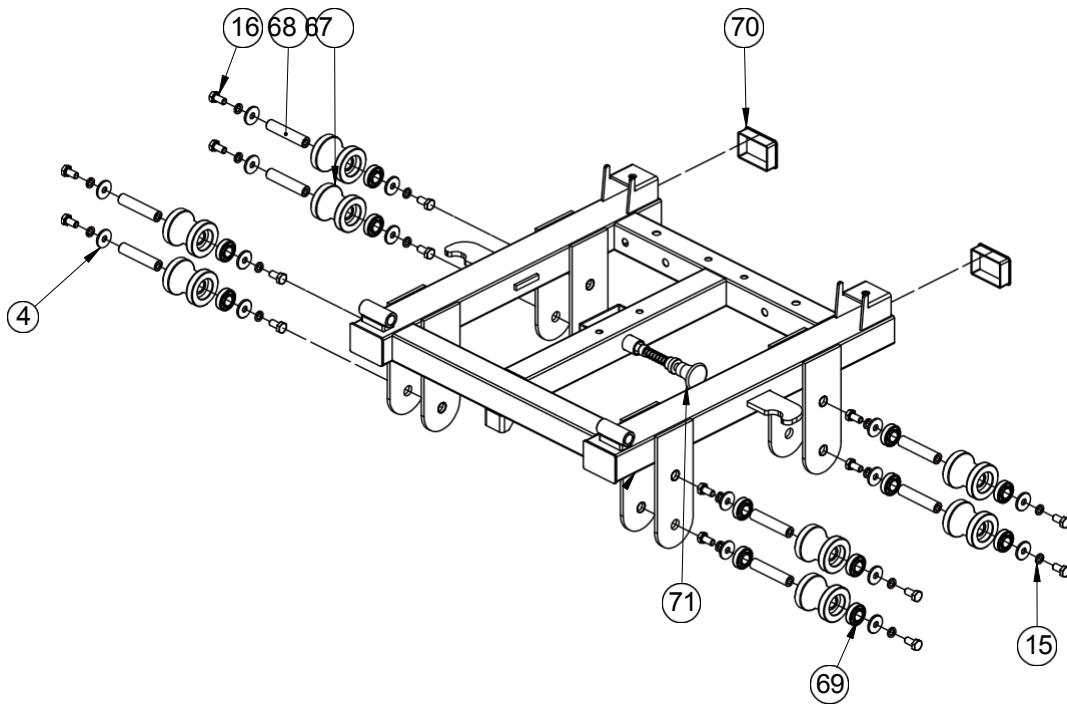

KEY NUMBER	DESCRIPTION OF THE PART	QUALITY
4	Large flat washer $\phi 30 \times \phi 10 \times 3$	16
15	Spring washer $\phi 10$	16
16	Hexagon bolt M10*20	16
67	Roller $\phi 59$	8
68	Internal threaded axle $\phi 17 \times 81$ -M10	8
69	Bearing 6003	16
70	Plug $50 \times 70 \times 2$	2
71	Pulling pin	1

ASSEMBLY DRAWING

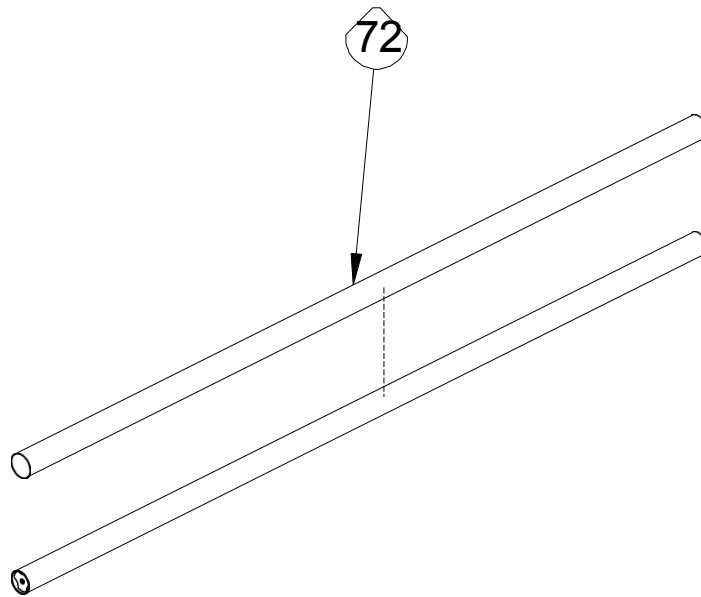

KEY NUMBER	DESCRIPTION OF THE PART	QUALITY
72	Stainless steel bar $\phi 50 \times 0.8$	1

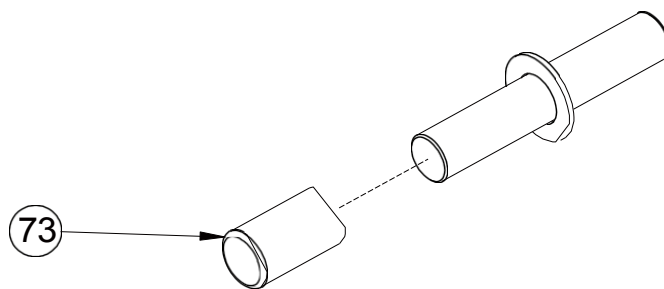

KEY NUMBER	DESCRIPTION OF THE PART	QUALITY
73	Pipe cover $\phi 30 \times \phi 25 \times 50$	1

ASSEMBLY DRAWING

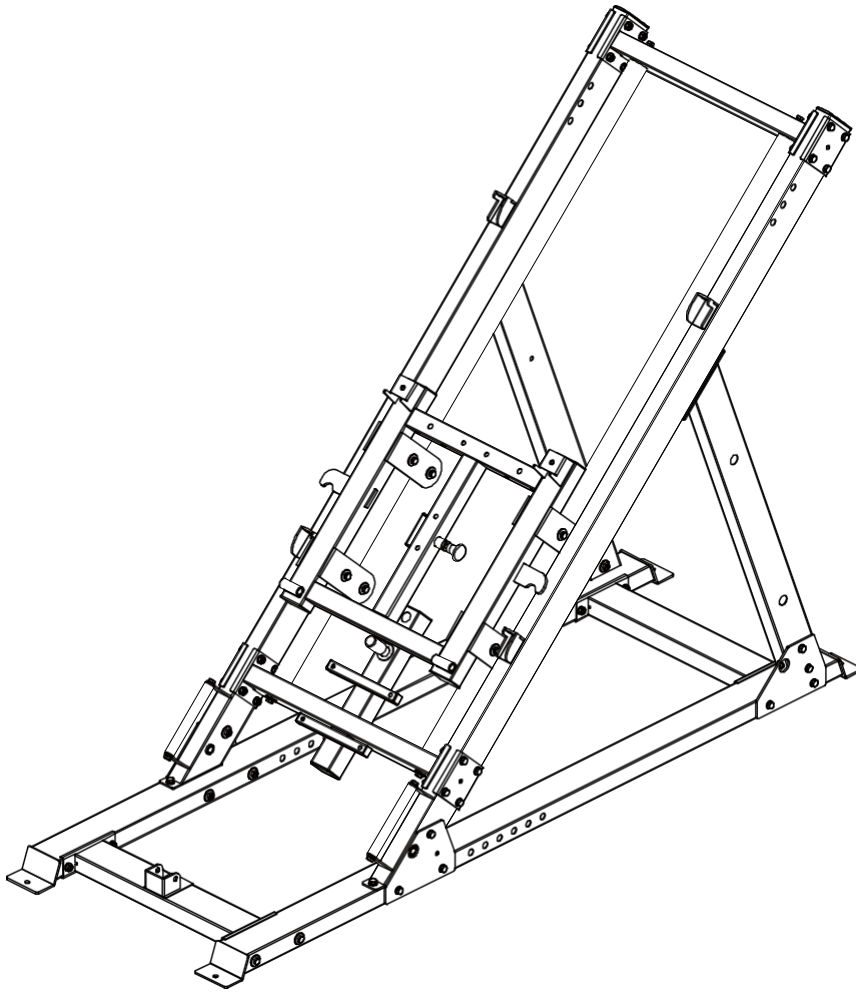

INSTALLATION INSTRUCTIONS IN STEP 3

1. Fix the guide rod down the fixed tube assembly part-18 to the main frame with M10*70-12 hex bolt, $\phi 10-5$ flat washer and M10-6 lock nut and 100*130*4 connection plate.
2. Secure the slide bar assembly, part 20, to the guide bar down the fixed tube, part 18, using an M10*30-24 hex bolt, a $\phi 10-15$ flexible washer, and a large $\phi 30 * \phi 10 * 3-4$ flat washer.
3. Insert the slide frame assembly, part 21, into the slide bar assembly, part 20.
4. Fix the fixed guide rod tube assembly - part 19 to the main frame using M10*70-12 hex bolt, $\phi 10-5$ flat washer and M10-6 lock nut and 100*130*4 connection plate.

ASSEMBLY

5. Secure the slide bar **ArtW201**, NtoG the fixed guide bar assembly, part 19, using an M10*30-24 hex bolt, a ϕ 10-15 flexible washer, and a large ϕ 30* ϕ 10*3-4 flat washer.

ASSEMBLY STEP 4

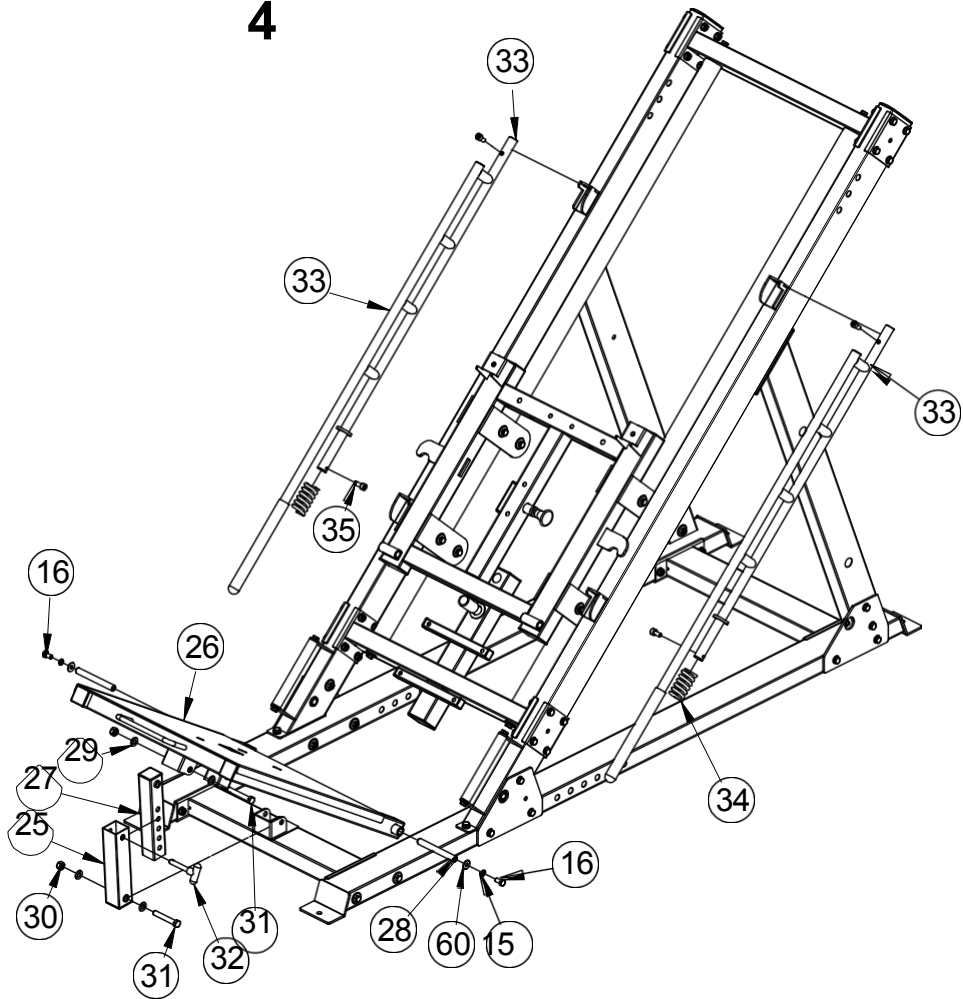

KEY NUMBER	DESCRIPTION OF THE PART	QUALITY
15	Spring washer $\phi 10$	4
16	Hexagon bolt M10*20	4
25	External leg press adjustment tube assembly	1
26	Footboard	1
27	Leg press adjustment assembly	1
28	Axle with internal thread $\phi 15,9 \times 135$	2
29	Flat washer $\phi 12$	4
30	Locking nut M12	2
31	Hexagon bolt M12*80	2
32	T-shaped pin	1
33	Part of the limit frame assembly	2
34	Spring	2
35	Hexagon head screws M10*20	4
60	Large flat washer $\phi 25 \times \phi 10 \times 2$	4

ASSEMBLY DRAWING

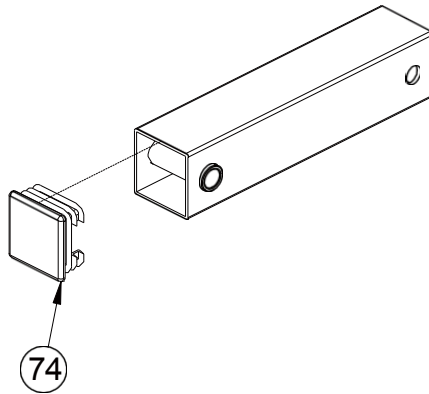

KEY NUMBER	DESCRIPTION OF THE PART	QUALITY
74	74 Pipe plug $\phi 50 \times 50 \times 2$ 1	1

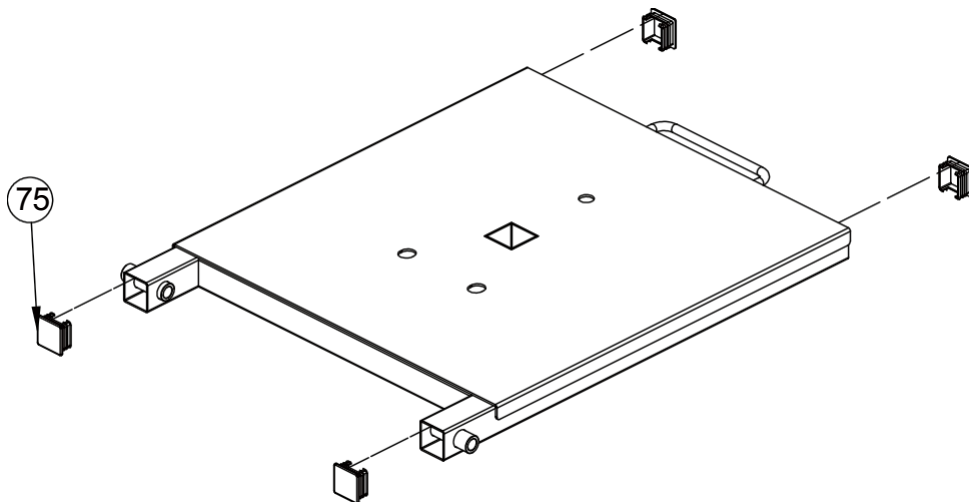

KEY NUMBER	DESCRIPTION OF THE PART	QUALITY
75	Tube plug $\phi 45 \times 45 \times 2$	4

ASSEMBLY DRAWING

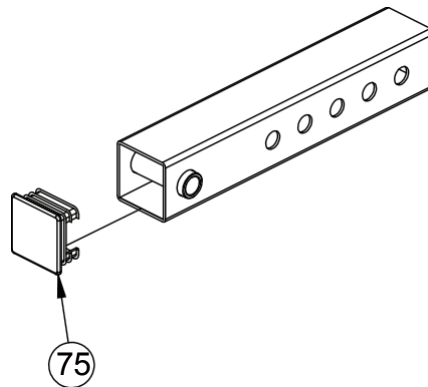

KEY NUMBER	DESCRIPTION OF THE PART	QUALITY
75	Tube plug $\phi 45 \times 45 \times 2$	4

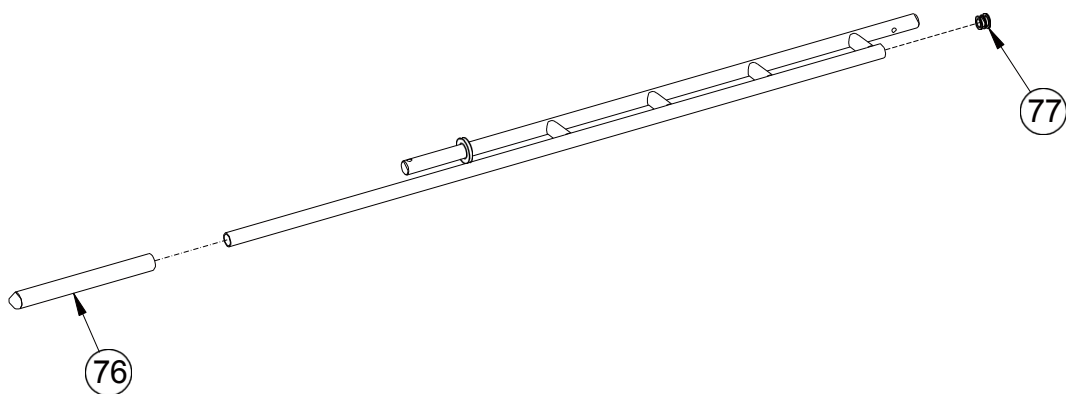

KEY NUMBER	DESCRIPTION OF THE PART	QUALITY
76	Handle cover $\phi 24,5 \times 280$	1

ASSEMBLY

77	DRAWIRNouGnd plug $\phi 25*2$	1
----	-------------------------------	---

ASSEMBLY DRAWING

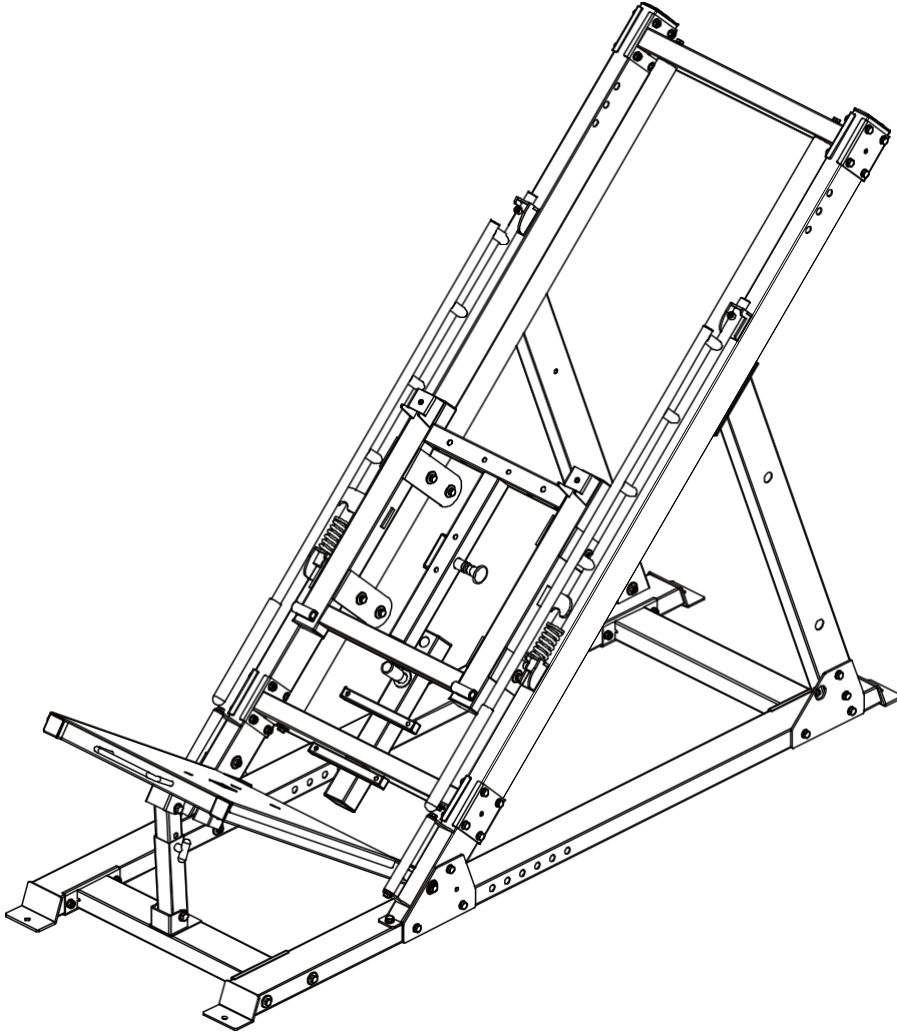

INSTALLATION INSTRUCTIONS IN STEP 4

1. Secure the end frame assembly, part 33, to the main frame using spring 34 and M10*20-35 hex head screws.
2. Fix the leg press outer tube assembly - part 25 to the main frame using M12*80 hex bolt - 31, flat washer $\phi 12$ - 29, lock nut M12 - 30.
3. Fasten the leg press adjustment tube assembly - part 27 to the leg plate - 26 using hexagon bolt M12*80 - 31, $\phi 12$ flat washer-29, lock nut M12-30.
4. Fix the footplate-26 to the main frame with M10*20-16 hex bolt, $\phi 10$ -15 flexible washer, $\phi 25$ * large flat washer $\phi 10$ *2-60 and $\phi 15.9$ *135 internally threaded axle.
5. Connect the outer tube assembly for the leg press adjustment of part 25 and the tube assembly

for the

ASSEMBLY

ASSEMBLY

adjusting the leg press pad with a T-shaped pin.

ASSEMBLY STEP 5

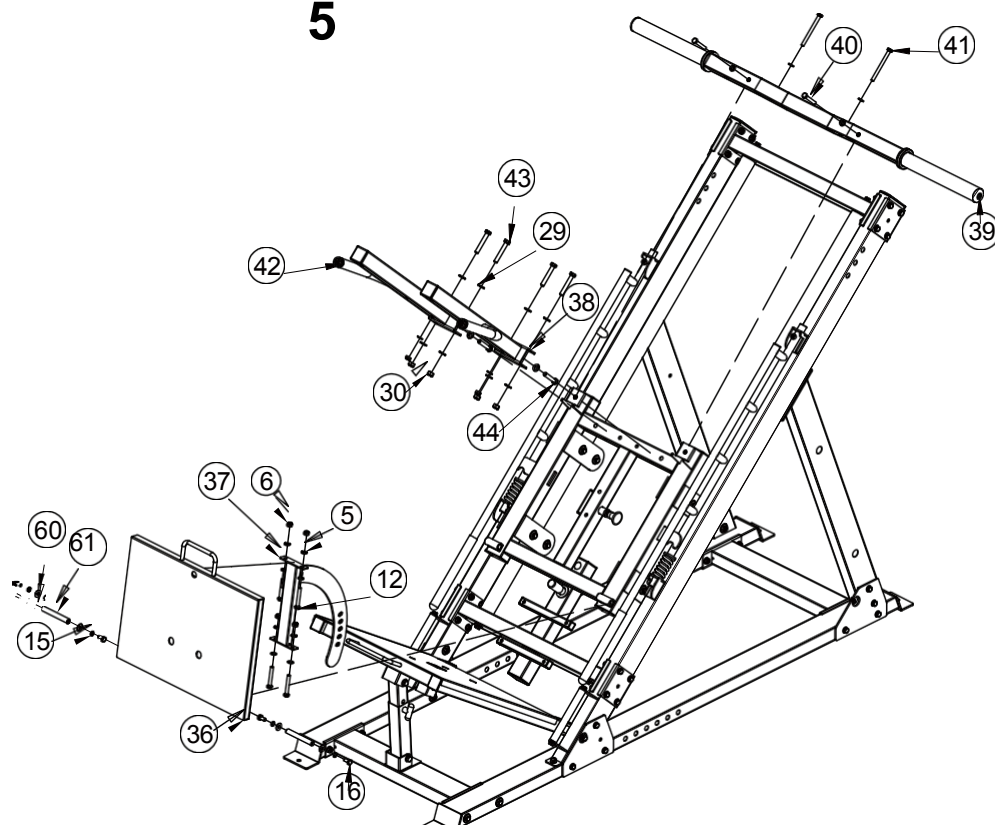

KEY NUMBER	DESCRIPTION OF THE PART	QUALITY
5	Flat washer $\phi 10$	14
6	Locking nut M10	6
12	Hexagon bolt M10*70	4
15	Spring washer $\phi 10$	4
16	Hexagon bolt M10*20	4
29	Flat washer $\phi 12$	10
30	Locking nut M12	4
36	Mounting plate upside down Part	1
37	Mounting part of the Regulatory Fixing Pipe	1
38	Shoulder pads Frame - right mounting part	1
39	Dumbbell holder frame	1
40	Hexagon bolt M10*65	2
41	Hexagon bolt M10*115	2
42	Shoulder pads Frame - left mounting part	1
43	Hexagon bolt M12*75	4
44	Hexagon bolt M12*65	2
60	Large flat washer $\phi 25 \times \phi 10 \times 2$	4
61	Axle with internal thread $\phi 15,9 \times 120$	2

ASSEMBLY DRAWING

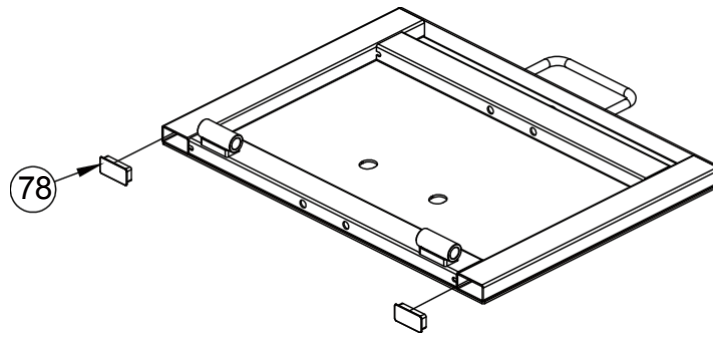

KEY NUMBER	DESCRIPTION OF THE PART	QUALITY
78	Pipe plug $\varnothing 25 \times 25 \times 1,5$	2

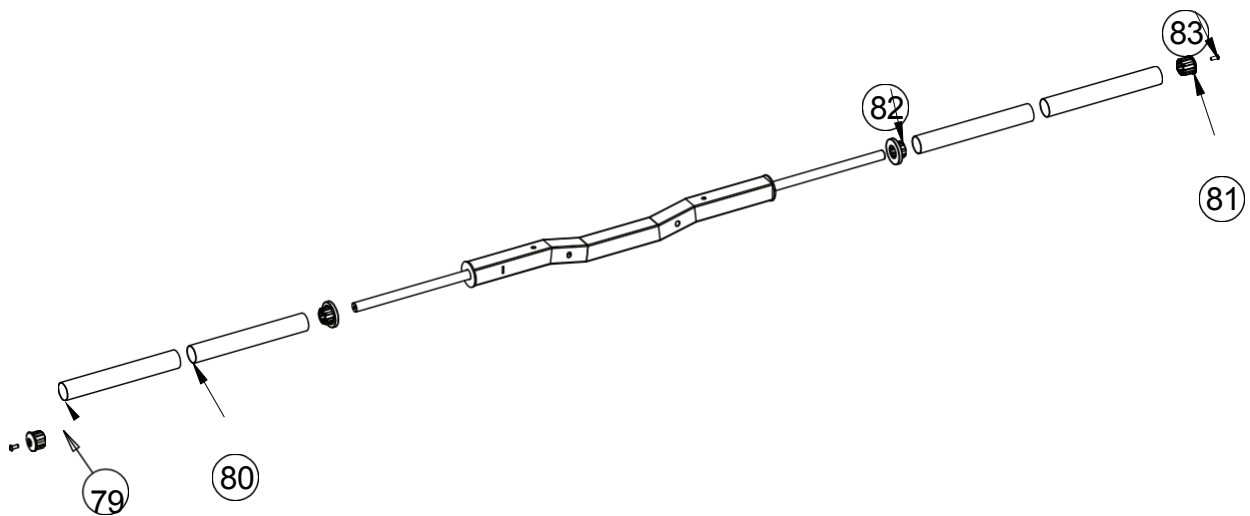

KEY NUMBER	DESCRIPTION OF THE PART	QUALITY	NUMB
79	$\varnothing 50 \times 345$ Stainless steel pipe $\varnothing 49,5 \times 6$		2
80	$\varnothing 48 \times 344$ Inner tube $\varnothing 48 \times 1,5$		2
81	End cap $\varnothing 50 \times \varnothing 44,8 \times \varnothing 25,5$		2
82	Middle cap $\varnothing 70 \times 44,8 \times \varnothing 25,5 \times 30$		2

ASSEMBLY

83	DRHAexWagInNhGead screws M8*20	2
----	--------------------------------	---

ASSEMBLY DRAWING

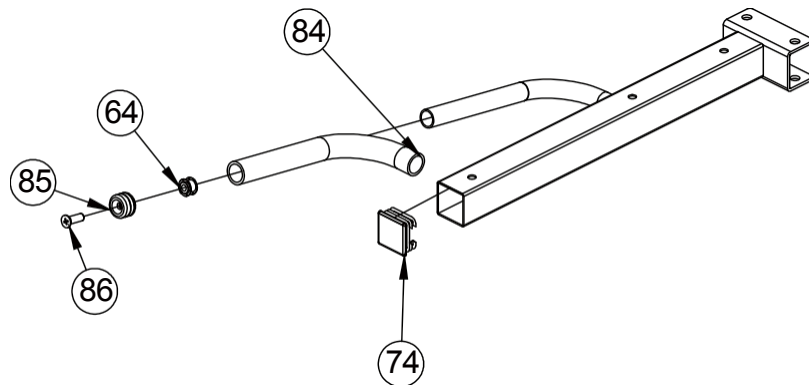

KEY NUMBER	DESCRIPTION OF THE PART	QUALITY
64	Double layer spring nut $\varnothing 23\text{-M10}$	1
74	Pipe plug $\varnothing 50\text{*}50\text{*}2$	1
84	Handle cover $\varnothing 32\text{*}310$	1
85	Fixing ring $\varnothing 31,5\text{*}\varnothing 25,5$	1
86	Phillips screw with countersunk head M10*25	1

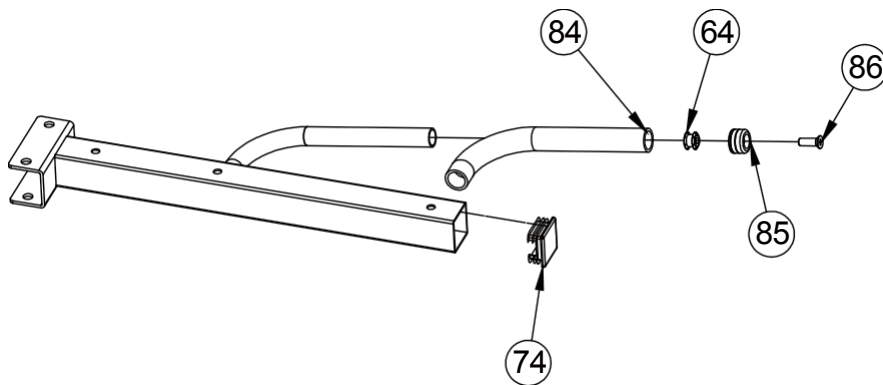

KEY NUMBER	DESCRIPTION OF THE PART	QUALITY
64	Double layer spring nut $\varnothing 23\text{-M10}$	1
74	Pipe plug $\varnothing 50\text{*}50\text{*}2$	1
84	Handle cover $\varnothing 32\text{*}310$	1
85	Fixing ring $\varnothing 31,5\text{*}\varnothing 25,5$	1
86	Phillips screw with countersunk head M10*25	1

ASSEMBLY DRAWING

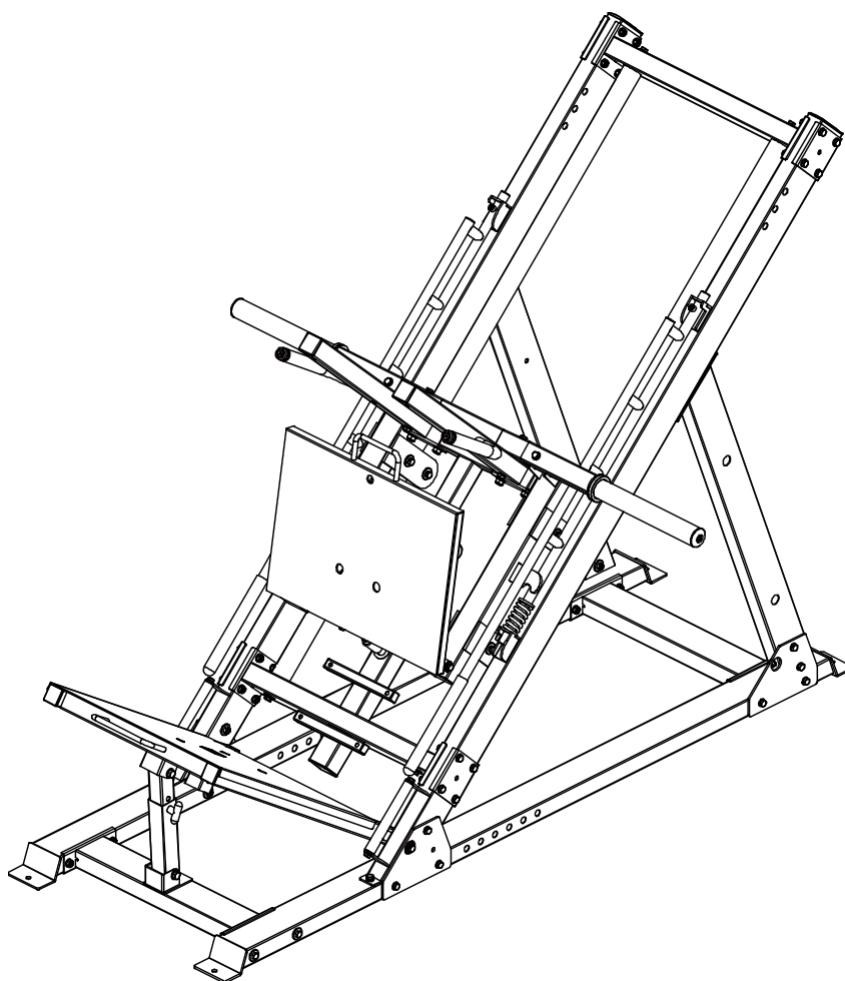

INSTALLATION INSTRUCTIONS IN STEP 5

1. Fix the frame shoulder pads - left part of the assembly-42 and the frame shoulder pads - right part of the assembly-38 to the main frame using hexagon bolt M12*75-43, flat washer $\phi 12-29$, lock nut M12-30 and hexagon bolt M12*65-44.
2. Fix the frame of the dumbbell holder-39 to the main frame with the hexagon bolt M10*65- 40, hexagon bolt M10*115-41, flat washer $\phi 10-5$ and lock nut M10- 6.
3. Fix the frame of the dumbbell plate holder-39 to the leg plate mounting part- 36 using the hexagon bolt M10*70-12, flat washer $\phi 10-5$ and lock nut vM10-6.
4. Attach the footplate mounting plate part-36 to the main frame using an M10*20-16 hex bolt, a $\phi 10-15$ flexible washer, a large flat washer $\phi 25*\phi 10*2-60$ and an axle with

ASSEMBLY

internal thread $\varphi 15$, ~~900~~ DRAWING

ASSEMBLY STEP 6

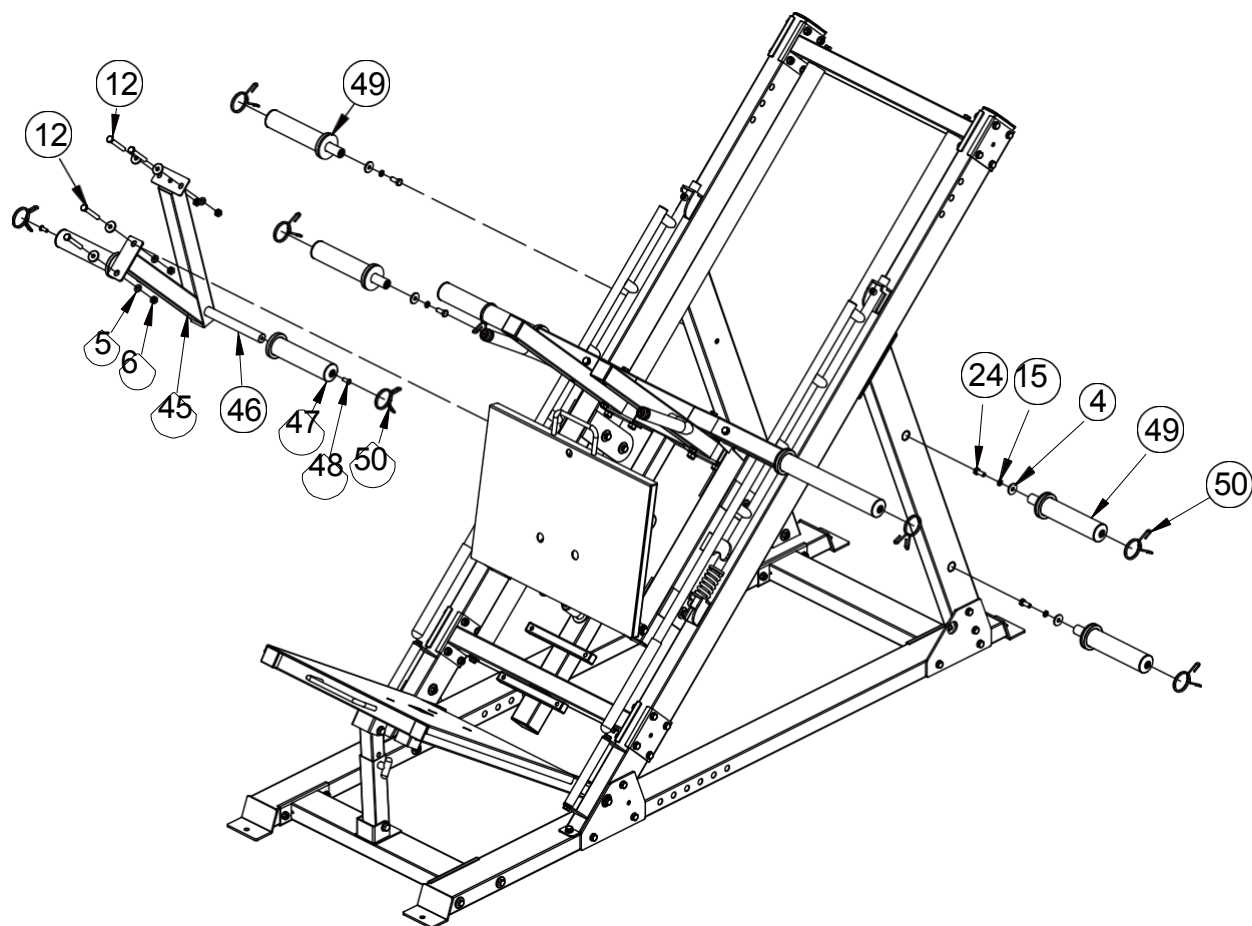

KEY ER	DESCRIPTION OF THE PARTQUALITY	NUMB
4	Large flat washer $\phi 30 \times \phi 10 \times 3$	8
5	Flat washer $\phi 10$	4
6	Locking nut M10	4
12	Hexagon bolt M10*70	4
15	Spring washer $\phi 10$	4
24	Hexagon bolt M10*30	4
45	Part of the lifting frame assembly	1
46	Inner bar for dumbbells	1
47	Holder for dumbbells	2
48	Hexagon head screws M8*20	2
49	Holder for dumbbells	4

ASSEMBLY STEP

50	6 Spring collar	8
----	------------------------	---

ASSEMBLY DRAWING

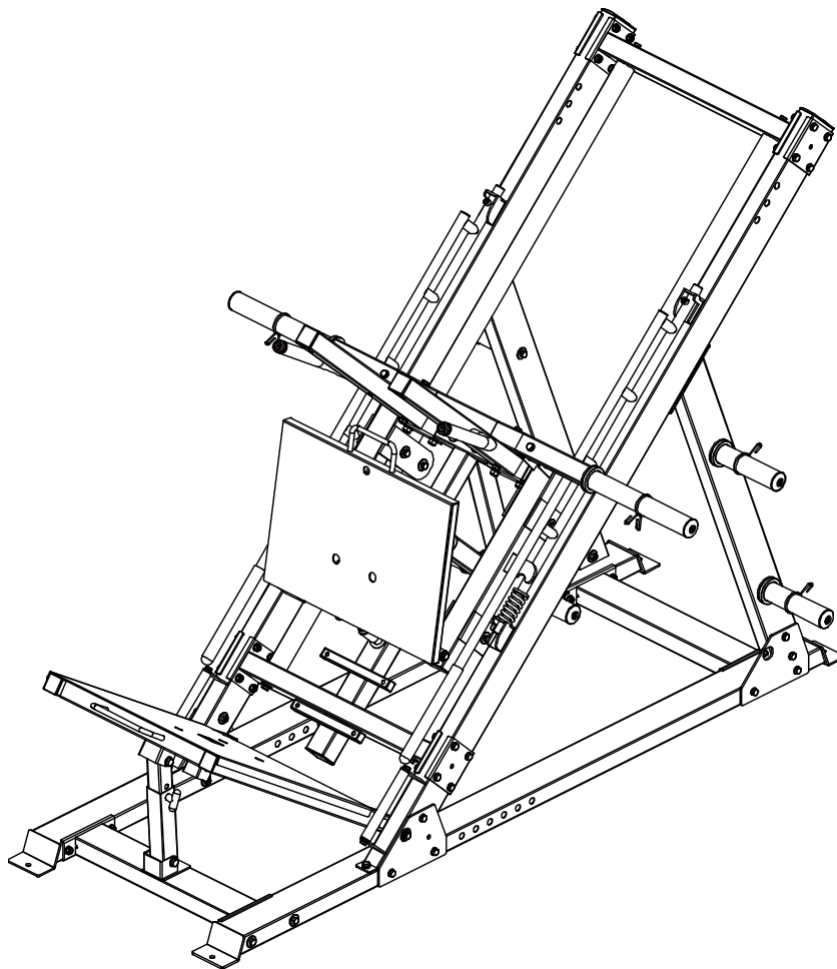

INSTALLATION INSTRUCTIONS IN STEP 6

1. Secure the lifting frame assembly, part 45, to the frame using hex bolt M10*70-12, flat washer $\phi 10-5$, large flat washer $\phi 30*\phi 10*3-4$ and lock nut vM10-6.
2. Attach the inner bar of the dumbbell-46 to the mounting part of the lifting frame-45 using M8*20-48 hex head screws and the dumbbell-47 plate holder.
3. Fix the dumbbell-49 plate holder to the main frame with an M10*30-24 hex bolt, a $\phi 10-15$ flexible washer and a large flat washer $\phi 30*\phi 10*3-4$.
4. Put the spring collar on the main frame.

ASSEMBLY STEP 7

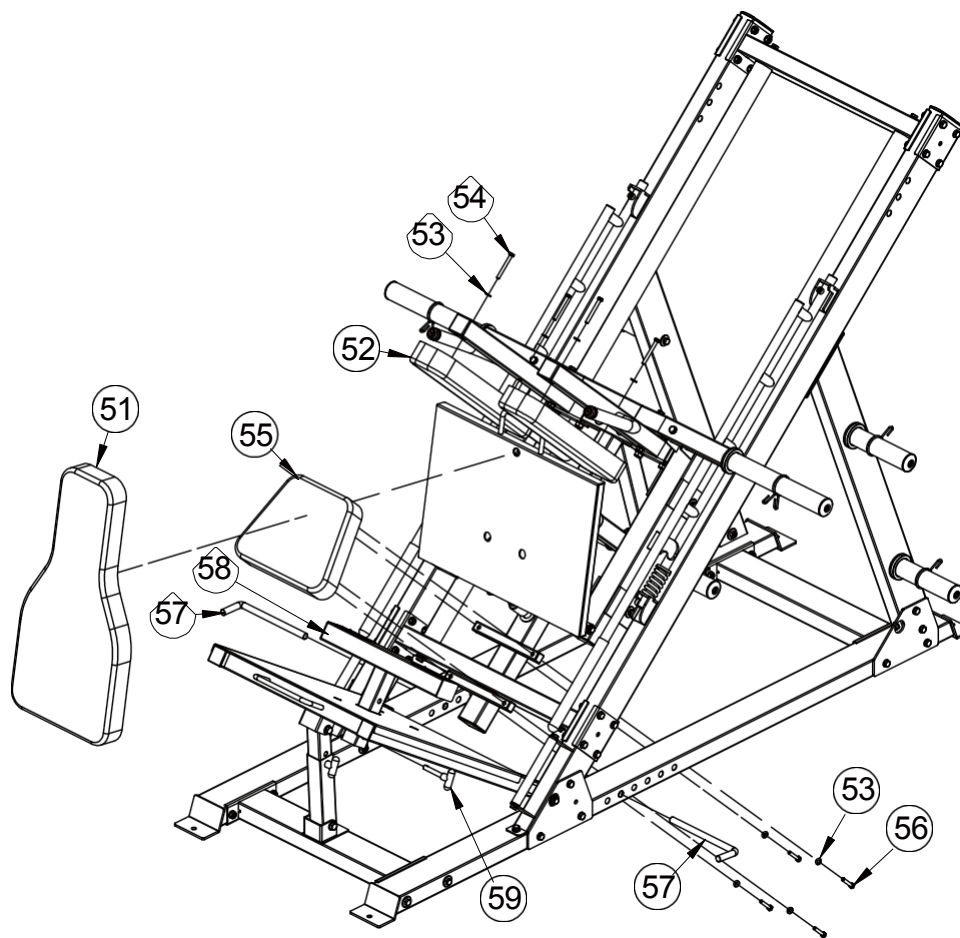

KEY ER	DESCRIPTION OF THE PARTQUALITY	NUMB
51	Rear pad	1
52	Shoulder pad	2
53	Flat washer $\varphi 8$	8
54	Hexagon bolt M8*70	4
55	Seat pad	1
56	Hexagon bolt M8*45	4
57	The Peg Band	2
58	Legs Brick frame	1
59	T-shaped pin	1

ASSEMBLY DRAWING

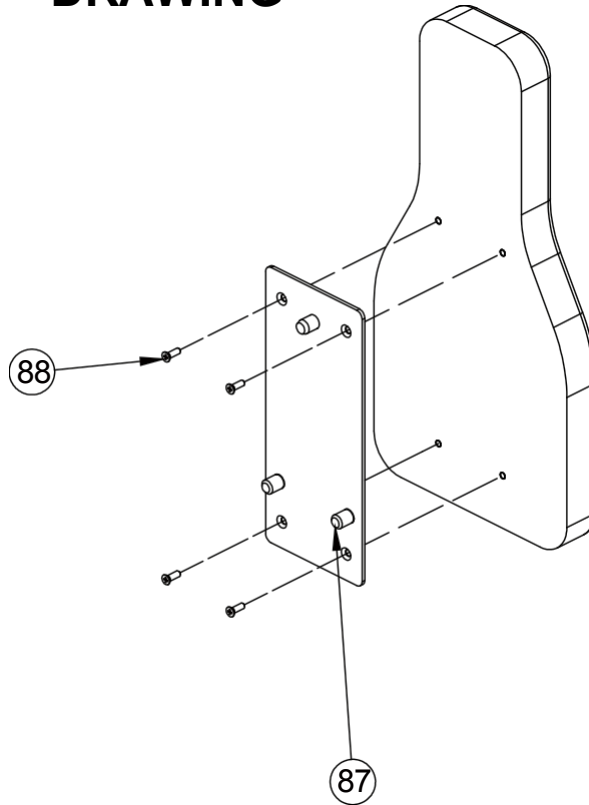

KEY NUMBER	DESCRIPTION OF THE PART	QUALITY
87	Rear washer fixing plate	1
88	Phillips screw with countersunk head M8*20	4

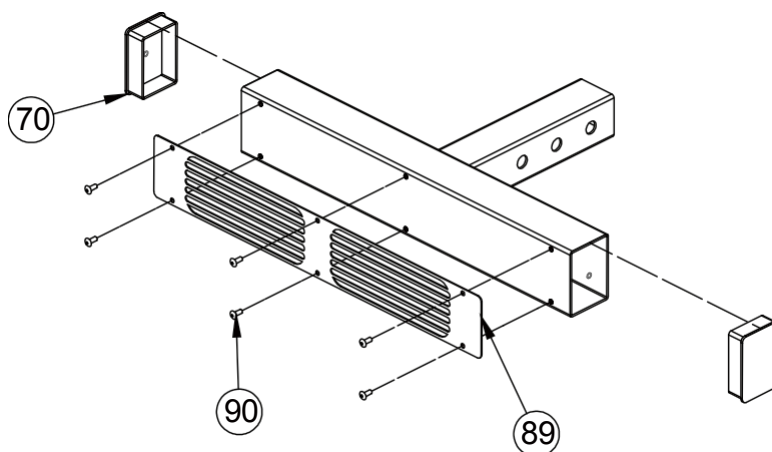

KEY NUMBER	PART DESCRIPTION	QUALITY
70	Plug 50*70*2	2

ASSEMBLY

89	DRAWIANntGi-slipsheet	2
90	Flat blind rivet with round head 4*10	6

ASSEMBLY DRAWING

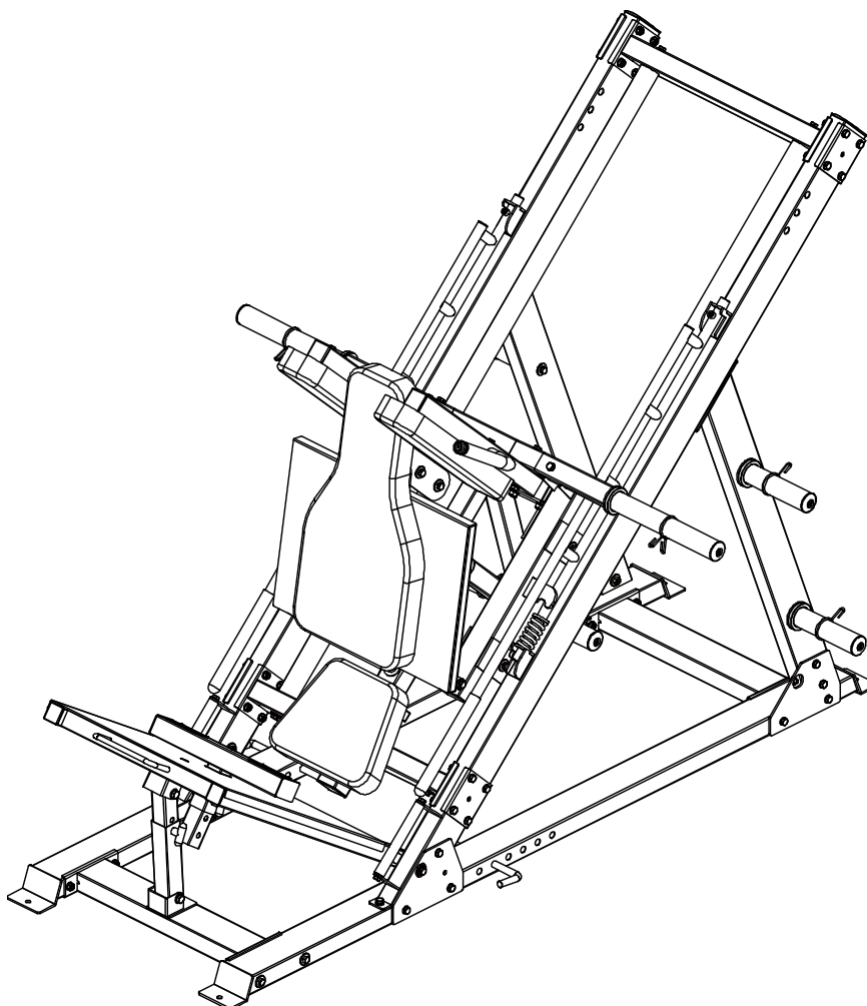

INSTALLATION INSTRUCTIONS STEP 7

1. Fix the seat washer-55 to the main frame with M8*45-56 hex bolt and ϕ 8-53 flat washer.
2. Fix the shoulder pad-52 to the main frame with the M8*70-54 hex bolt and ϕ 8-53 flat washer.
3. Place the rear washer-51 on the mounting plate with the footers part-36.
4. Place the foot brick frame-58 on the lower foot plate-26. Use a ϕ 12*70 t-59 pin.

ASSEMBLY

5. Fit the strap pin-57 to the mDaRin fAramWe. **ING**