

FORCE^{USA}

ORIGINAL LEG PRESS HACK SQUAT

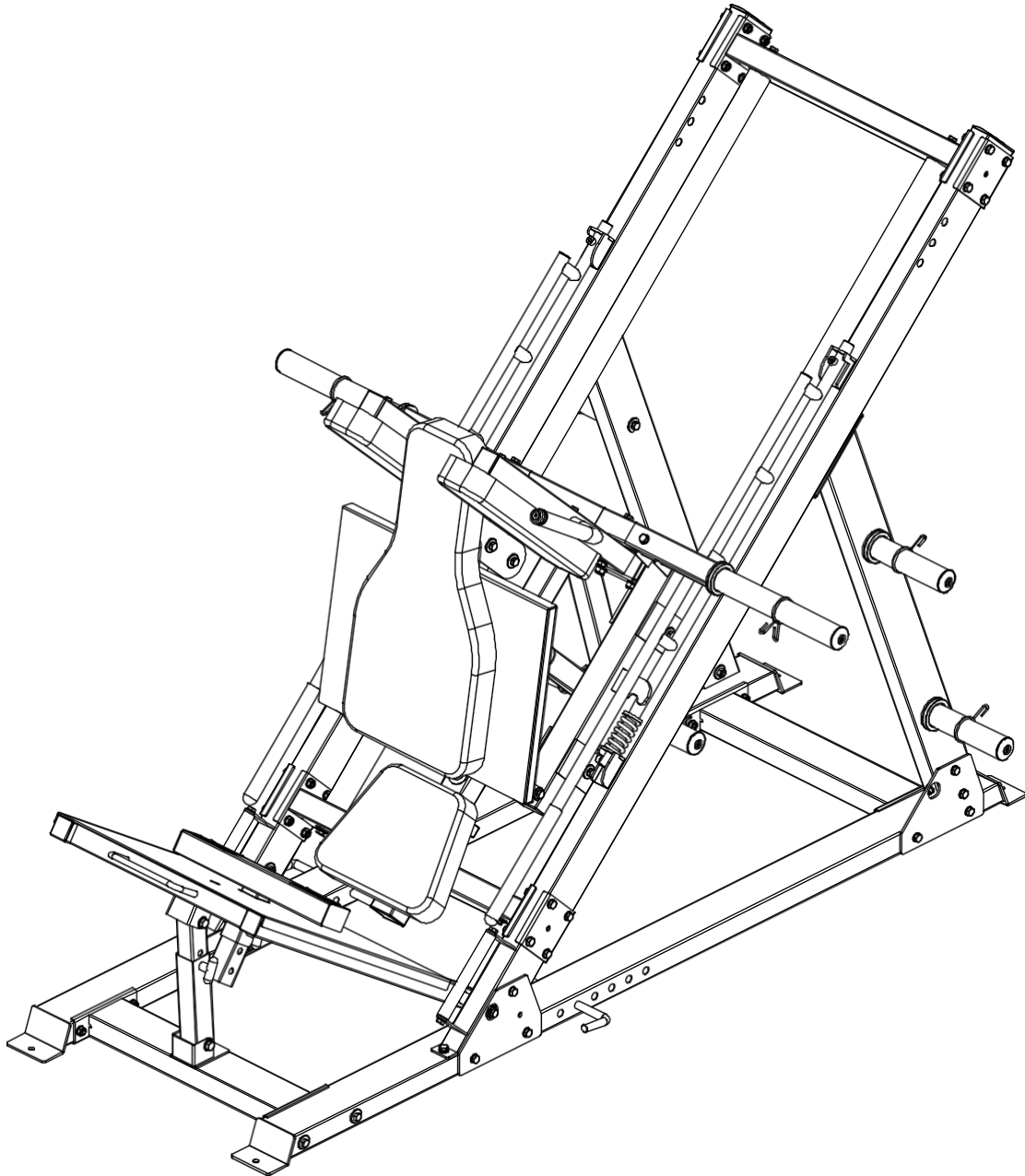

OWNERS MANUAL | F-MLPHS-V2

TABLE OF CONTENTS

Parts List	2-5
Assembly Step 1	6-7
Assembly Step 2	8-10
Assembly Step 3	11-14
Assembly Step 4	15-18
Assembly Step 5	19-22
Assembly Step 6	23-24
Assembly Step 7	25-27

PARTS LIST

KEY NUMBER	DESCRIPTION OF PART	QUANTITY
1	Ground Tube-Right	1
2	Ground Link Tube	1
3	Front Ground Tube	1
4	Big Flat Washer $\phi 30 \times \phi 10 \times 3$	48
5	Flat Washer $\phi 10$	86
6	Lock Nut M10	46
7	Hexagon Bolt M10*120	12
8	Ground Tube-Left	1
9	Fixing Plate	4
10	Back Support Tube	1
11	Back Support Tube-Left	1
12	Hexagon Bolt M10*70	30
13	Hexagon Bolt M10*115	2
14	Inclined Tube Assembly Part	1
15	Spring Washer $\phi 10$	38
16	Hexagon Bolt M10*20	34
17	Inclined Tube-Right Assembly Part	1
18	Guide Rod Down Fixed Tube Assembly Part	1
19	Guide Rod Fixed Tube Assembly Part	1
20	Slide Rod Assembly Part	2
21	Slide Frame Assembly Part	1
22	Limit Rod Assembly Part	1
23	100*130*4 Link Plate	4
24	Hexagon Bolt M10*30	8
25	Leg Press Adjust Outer Tube Assembly Part	1
26	Feet Plate	1

PARTS LIST

KEY NUMBER	DESCRIPTION OF PART	QUANTITY
27	Leg Press Adjust Tube Assembly Part	1
28	Internal Thread Axle $\phi 15.9 \times 135$	2
29	Flat Washer $\phi 12$	14
30	Lock Nut M12	6
31	Hexagon Bolt M12*80	2
32	T Shape Pin	1
33	Limit Frame Assembly Part	2
34	Spring	2
35	Hexagon Socket Button Head Screws M10*20	4
36	Up Feet Plate Assembly Part	1
37	Regulating Fixing Tube Assembly Part	1
38	Shoulder Pads Frame-Right Assembly Part	1
39	Barbell Plate Holder Frame	1
40	Hexagon Bolt M10*65	2
41	Hexagon Bolt M10*115	2
42	Shoulder Pads Frame-Left Assembly Part	1
43	Hexagon Bolt M12*75	4
44	Hexagon Bolt M12*65	2
45	Lifting Frame Assembly Part	1
46	Barbell Inner Rod	1
47	Barbell Plate Holder	2
48	Hexagon Socket Button Head Screws M8*20	2
49	Barbell Plate Holder	4
50	Spring Collar	8
51	Back Pad	1
52	Shoulder Pad	2

PARTS LIST

KEY NUMBER	DESCRIPTION OF PART	QUANTITY
53	Flat Washer $\phi 8$	8
54	Hexagon Bolt M8*70	4
55	Seat Pad	1
56	Hexagon Bolt M8*45	4
57	Band Peg	2
58	Feet Brick Frame	1
59	T Shape Pin	1
60	Big Flat Washer $\phi 25 \phi * 10 * 2$	8
61	Internal Thread Axle $\phi 15.9 * 120$	2
62	Handle Tube	2
63	Tube Plug 50*100*2	2
64	Two Layer Spring Nut $\phi 23 - M10$	2
65	Tube Plug $\phi 60 * 60 * 2$	1
66	Tube Plug $\phi 25 * 25 * 1.5$	4
67	Roller $\phi 59$	8
68	Internal Thread Axle $\phi 17 * 81 - M10$	8
69	Bearing 6003	16
70	Plug 50*70*2	4
71	Pull Pin	1
72	Stainless Steel Rod $\phi 50 * 0.8$	1
73	Tube Cover $\phi 30 * \phi 25 * 50$	1
74	Tube Plug $\phi 50 * 50 * 2$	3
75	Tube Plug $\phi 45 * 45 * 2$	5
76	Handle Cover $\phi 24.5 * 280$	1
77	Round Plug $\phi 25 * 2$	1
78	Tube Plug $\phi 25 * 25 * 1.5$	2

PARTS LIST

KEY NUMBER	DESCRIPTION OF PART	QUANTITY
79	φ50*345 Stainless Steel Tube φ49.5*6	2
80	φ48*344 Inner Tube φ48*1.5	2
81	End Cap φ50*φ44.8*φ25.5	2
82	Middle Cap φ70*φ44.8*φ25.5*30	2
83	Hexagon Socket Button Head Screws M8*20	2
84	Handle Cover φ32*310	2
85	Retaining Ring φ31.5*φ25.5	2
86	Cross Recessed Countersunk Head Screw M10*25	2
87	Back Pad Fixing Plate	1
88	Cross Recessed Countersunk Head Screw M8*20	4
89	Anti-Slip Sheet	2
90	Flat Round Head Blind Rivet 4*10	6
91	Two Layer Spring Nut φ29-M10	2



Bolt Length Gauge

ASSEMBLY STEP 1

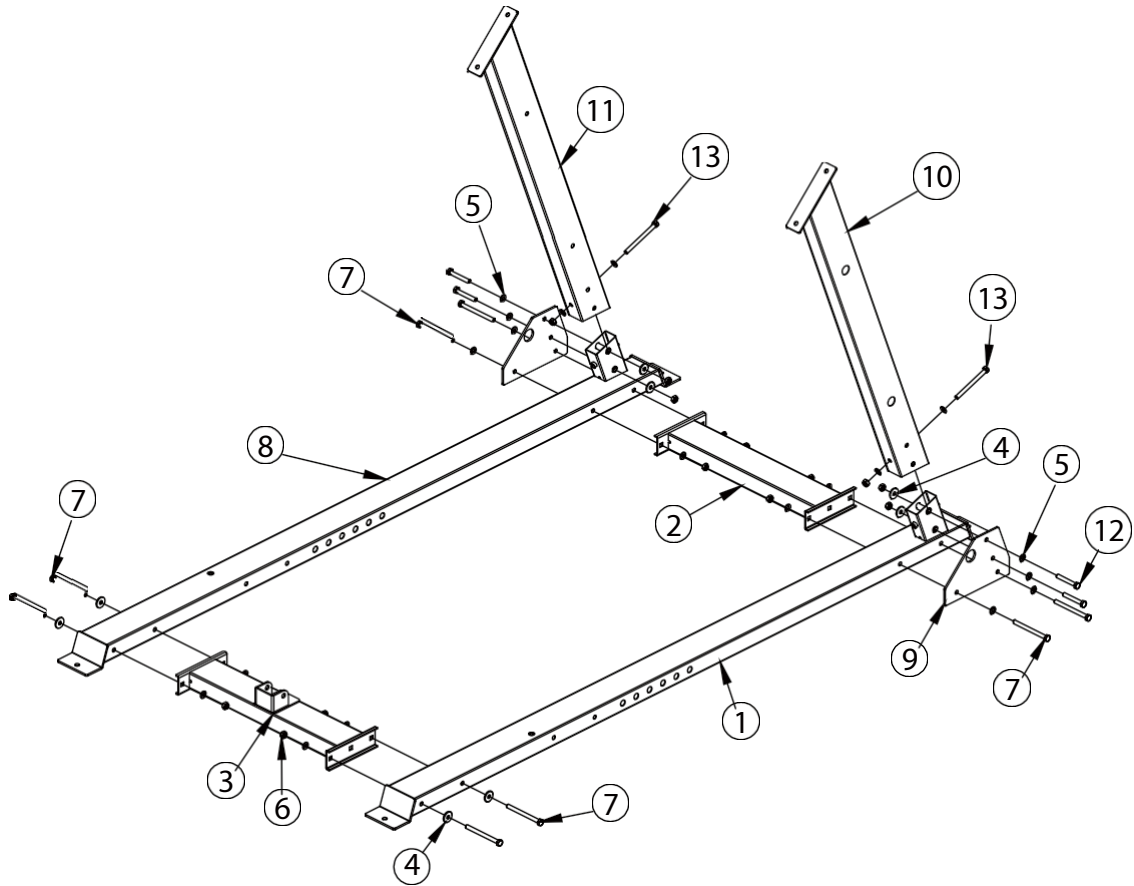

KEY NUMBER	DESCRIPTION OF PART	QUANTITY
1	Ground Tube-Right	1
2	Ground Link Tube	1
3	Front Ground Tube	1
4	Big Flat Washer $\phi 30 \times \phi 10 \times 3$	8
5	Flat Washer $\phi 10$	20
6	Lock Nut M10	14
7	Hexagon Bolt M10*120	8
8	Ground Tube-Left	1
9	Fixing Plate	2
10	Back Support Tube	1
11	Back Support Tube-Left	1
12	Hexagon Bolt M10*70	4
13	Hexagon Bolt M10*115	2

ASSEMBLY DRAWING

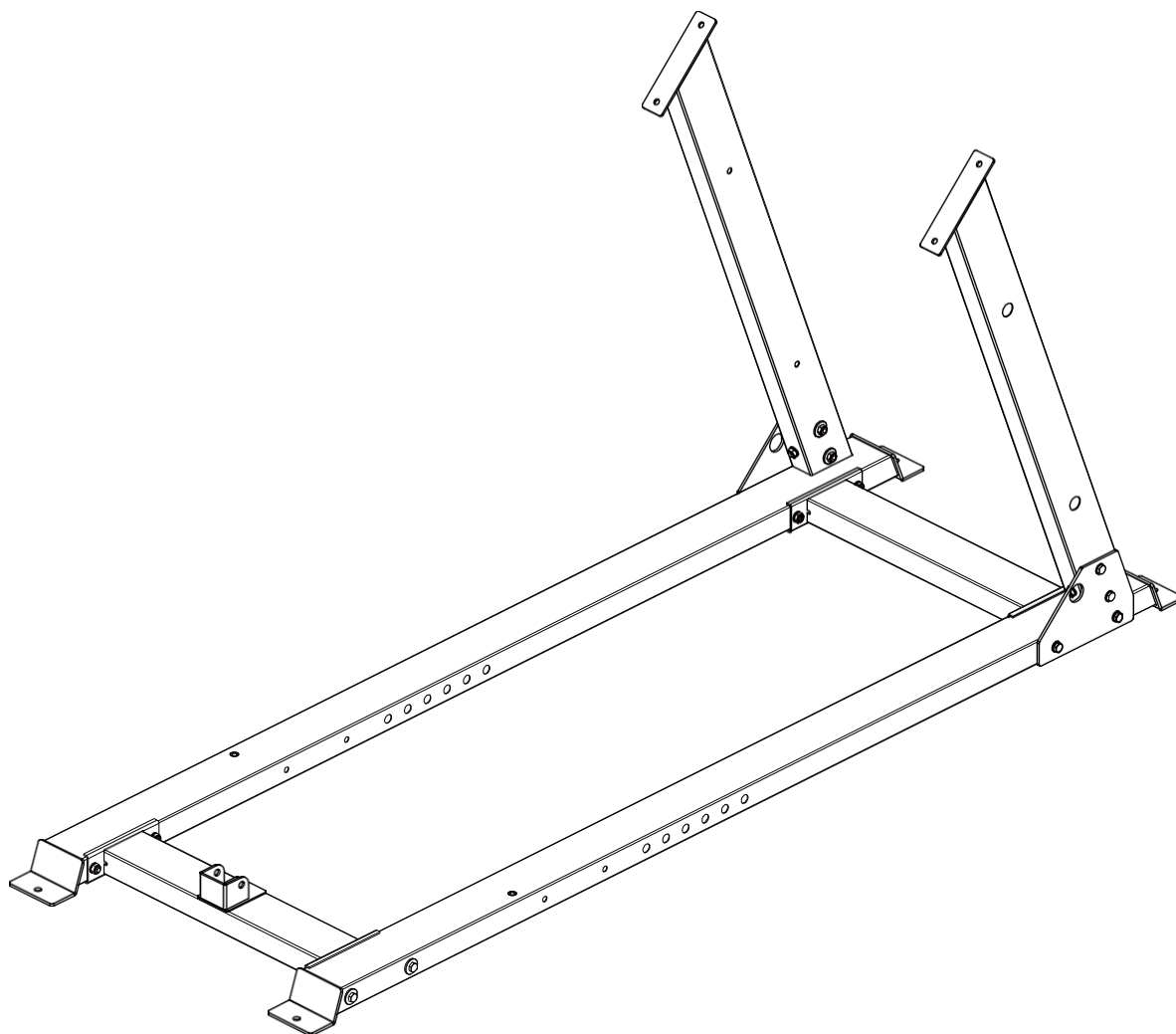

ASSEMBLY STEP 1 INSTRUCTIONS

1. Link front ground tube-3, ground tube-right-1 and ground tube-left-8 use M10*120 hexagon bolt-7, $\phi 30^* \phi 10^* 3$ big at washer-4, $\phi 10$ at washer-5 and M10 lock nut-6.
2. Link ground link tube-3, ground tube-right-1 and ground tube-left-8 use M10*120 hexagon bolt-7, $\phi 30^* \phi 10^* 3$ big at washer-4, $\phi 10$ at washer-5 and M10 lock nut.
3. Fix back support tube-left-11 on ground tube-left-8 use M10*115 hexagon bolt-13, $\phi 10$ at washer-5, M10 lock nut-6 and fixing plate-9.
4. Fix back support tube-10 on ground tube-left-8 use M10*115 hexagon bolt-13, $\phi 10$

ASSEMBLY DRAWING

at washer-5, M10 lock nut-6 and fixing plate-9.

ASSEMBLY STEP 2

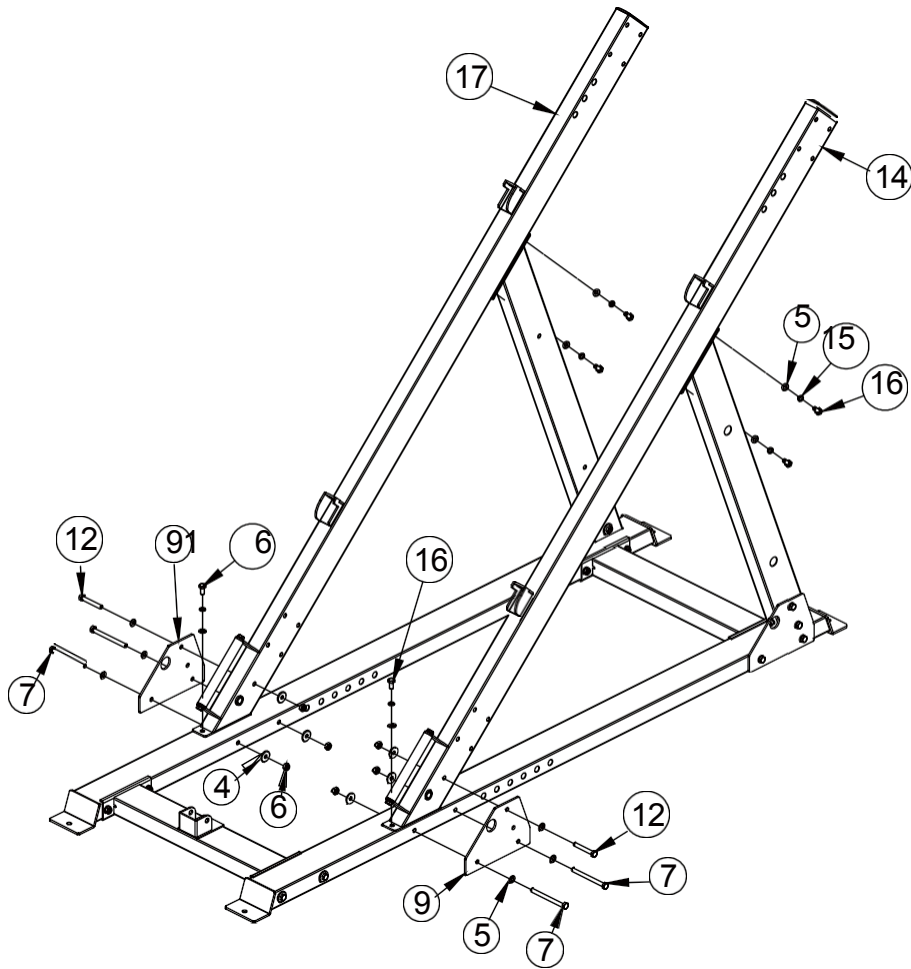

KEY NUMBER	DESCRIPTION OF PART	QUANTITY
4	Big Flat Washer $\phi 30 \times \phi 10 \times 3$	6
5	Flat Washer $\phi 10$	12
6	Lock Nut M10	6
7	Hexagon Bolt M10*120	4
9	Fixing Plate	2
12	Hexagon Bolt M10*70	2
14	Inclined Tube Assembly Part	1
15	Spring Washer $\phi 10$	6
16	Hexagon Bolt M10*20	6
17	Inclined Tube-Right Assembly Part	1

ASSEMBLY DRAWING

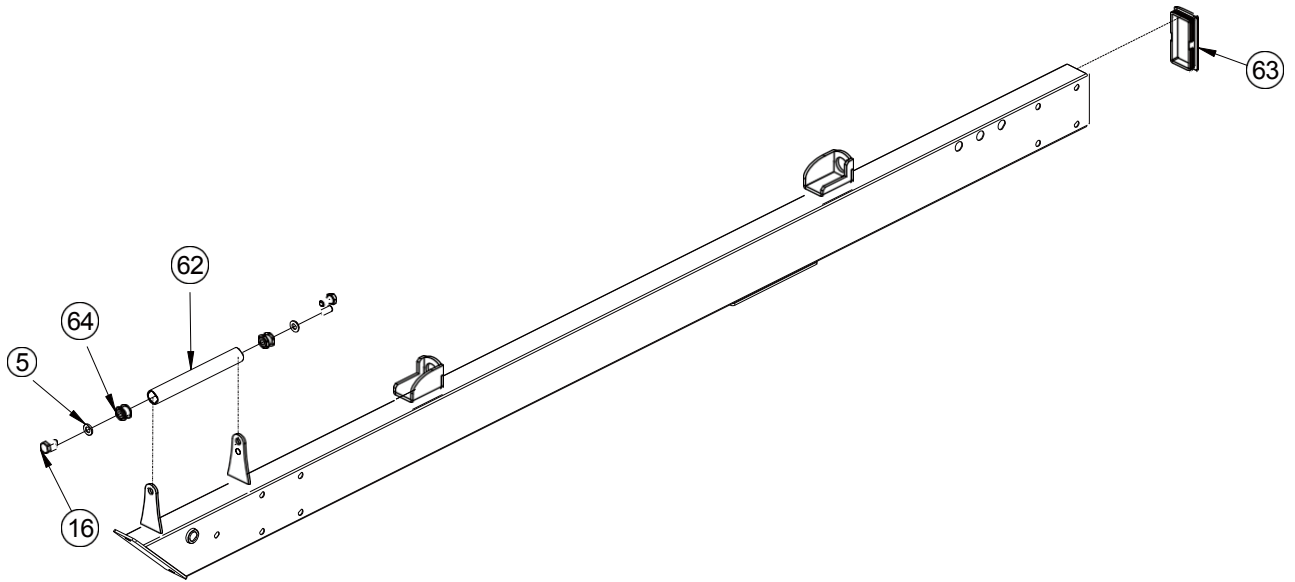

KEY NUMBER	DESCRIPTION OF PART	QUANTITY
5	Flat Washer $\phi 10$	2
16	Hexagon Bolt M10*20	2
62	Handle Tube	1
63	Tube Plug 50*100*2	1
91	Two Layer Spring Nut $\phi 29$ -M10	2

ASSEMBLY DRAWING

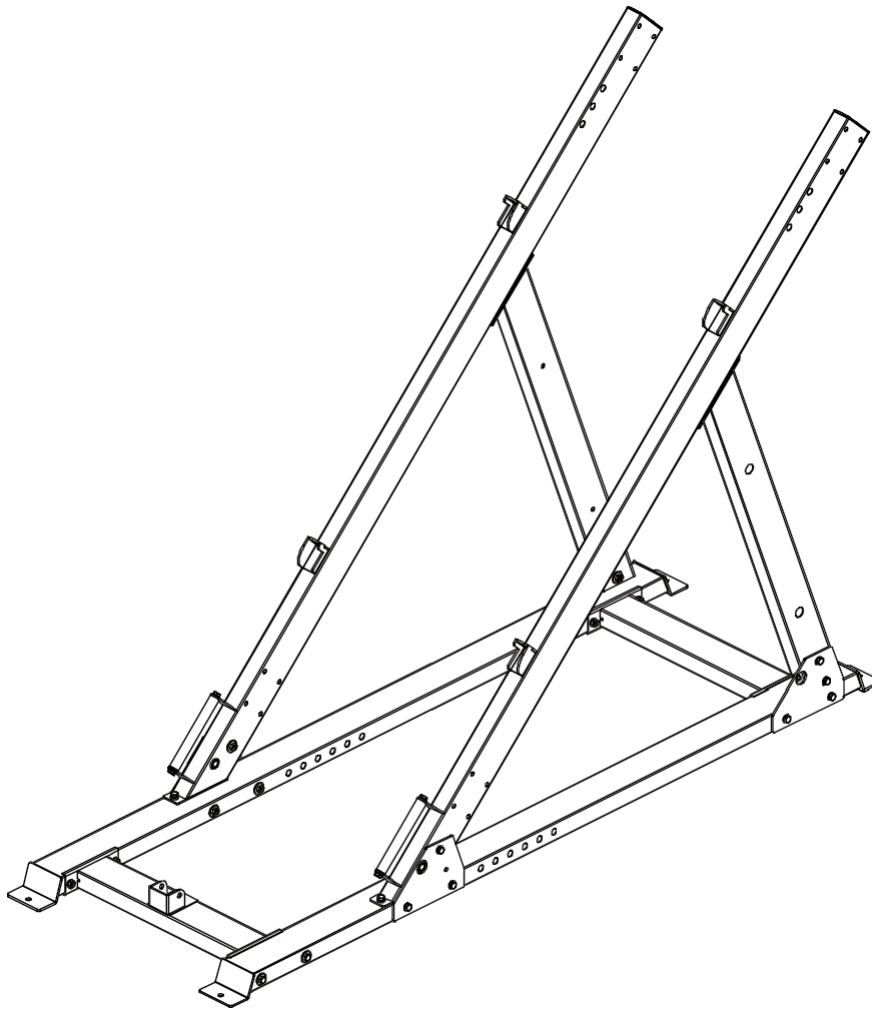

ASSEMBLY STEP 2 INSTRUCTIONS

1. Fix inclined tube assembly part-14 and inclined tube-right assembly part-17 on main frame use M10*120 hexagon bolt-7, $\phi 30*\phi 10*3$ big flat washer-4, $\phi 10$ flat washer-5 and M10 lock nut-6, fixing plate-9, M10*20 hexagon bolt-16 and $\phi 10$ spring washer-15.

ASSEMBLY STEP 3

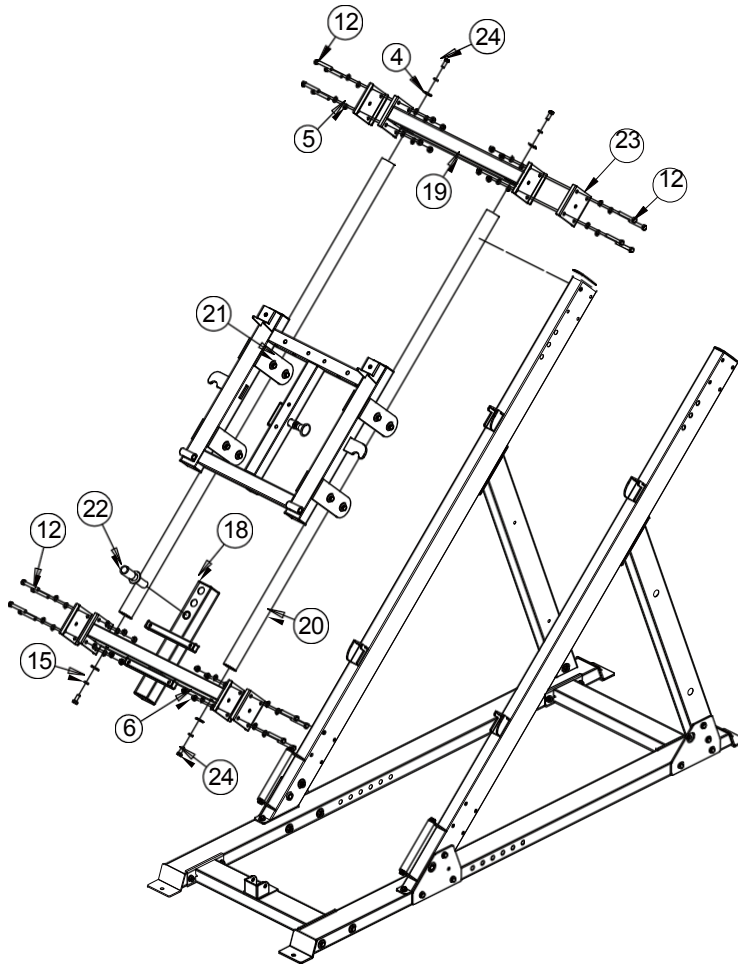

KEY NUMBER	DESCRIPTION OF PART	QUANTITY
4	Big Flat Washer $\phi 30 \times \phi 10 \times 3$	4
5	Flat Washer $\phi 10$	32
6	Lock Nut M10	16
12	Hexagon Bolt M10*70	16
15	Spring Washer $\phi 10$	4
18	Guide Rod Down Fixed Tube Assembly Part	1
19	Guide Rod Fixed Tube Assembly Part	1
20	Slide Rod Assembly Part	2
21	Slide Frame Assembly Part	1
22	Limit Rod Assembly Part	1
23	100*130*4 Link Plate	4
24	Hexagon Bolt M10*30	4

ASSEMBLY DRAWING

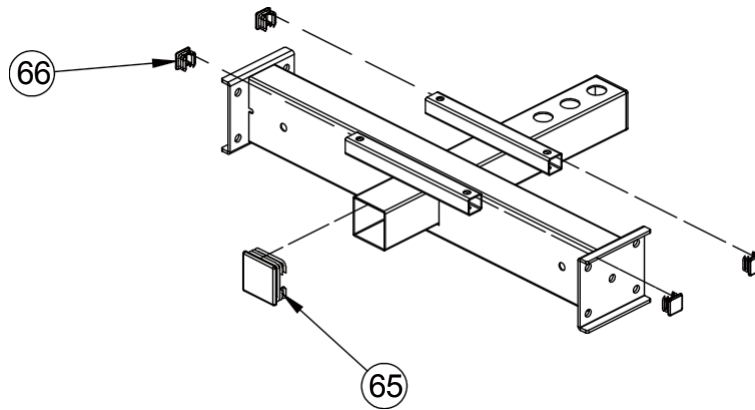

KEY NUMBER	DESCRIPTION OF PART	QUANTITY
65	Tube Plug $\phi 60 \times 60 \times 2$	1
66	Tube Plug $\phi 25 \times 25 \times 1.5$	4

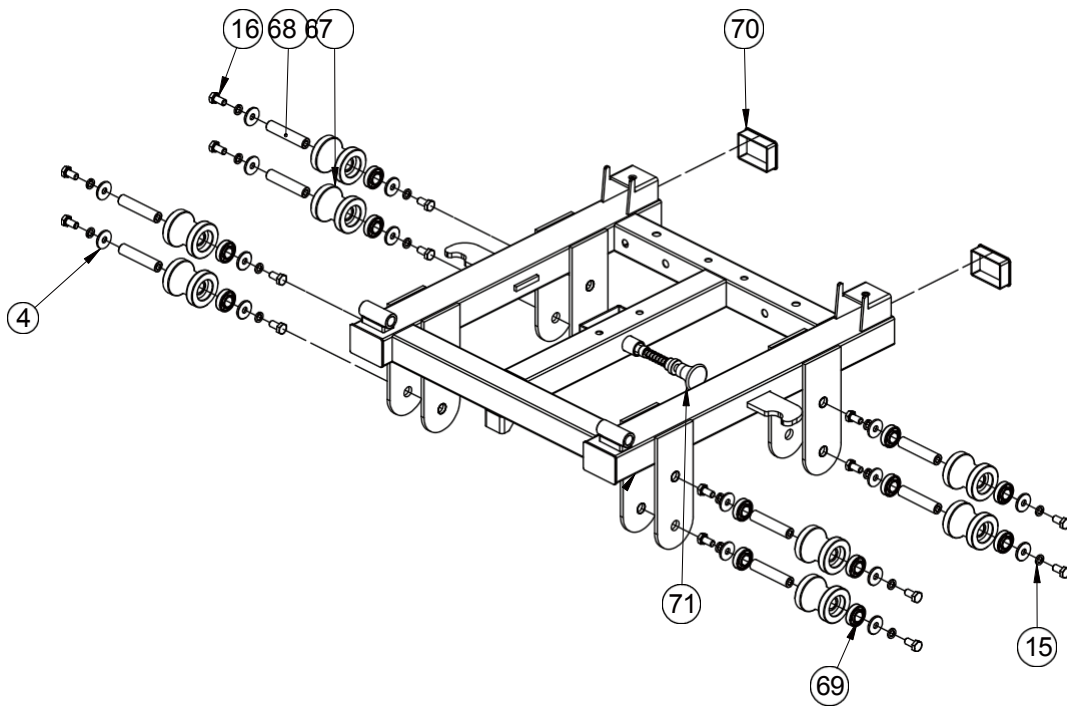

KEY NUMBER	DESCRIPTION OF PART	QUANTITY
4	Big Flat Washer $\phi 30 \times \phi 10 \times 3$	16
15	Spring Washer $\phi 10$	16
16	Hexagon Bolt M10*20	16
67	Roller $\phi 59$	8
68	Internal Thread Axle $\phi 17 \times 81 - M10$	8
69	Bearing 6003	16
70	Plug $50 \times 70 \times 2$	2
71	Pull Pin	1

ASSEMBLY DRAWING

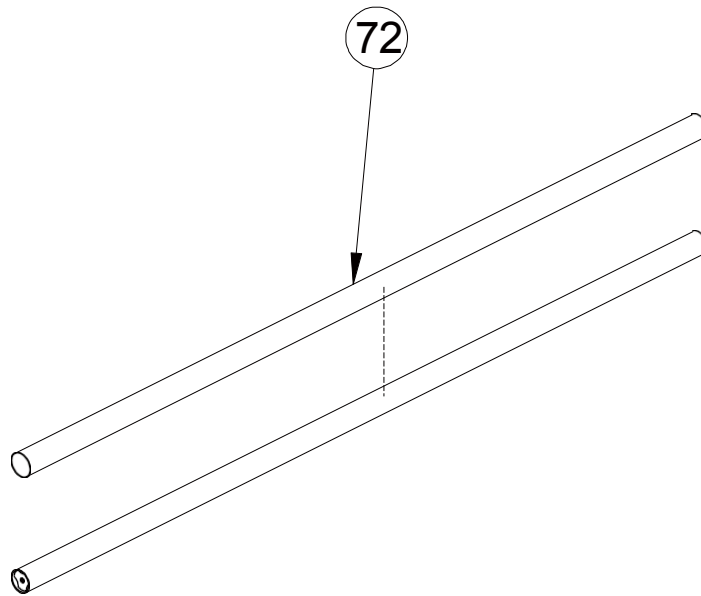

KEY NUMBER	DESCRIPTION OF PART	QUANTITY
72	Stainless Steel Rod $\phi 50 \times 0.8$	1

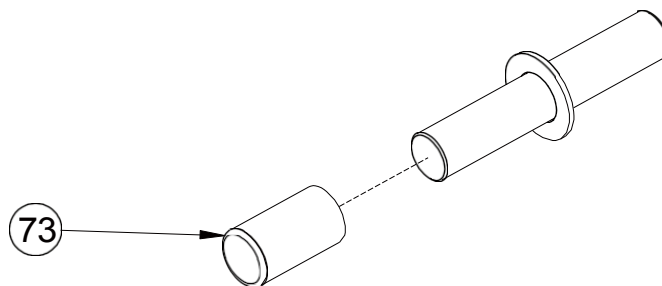

KEY NUMBER	DESCRIPTION OF PART	QUANTITY
73	Tube Cover $\phi 30 \times \phi 25 \times 50$	1

ASSEMBLY DRAWING

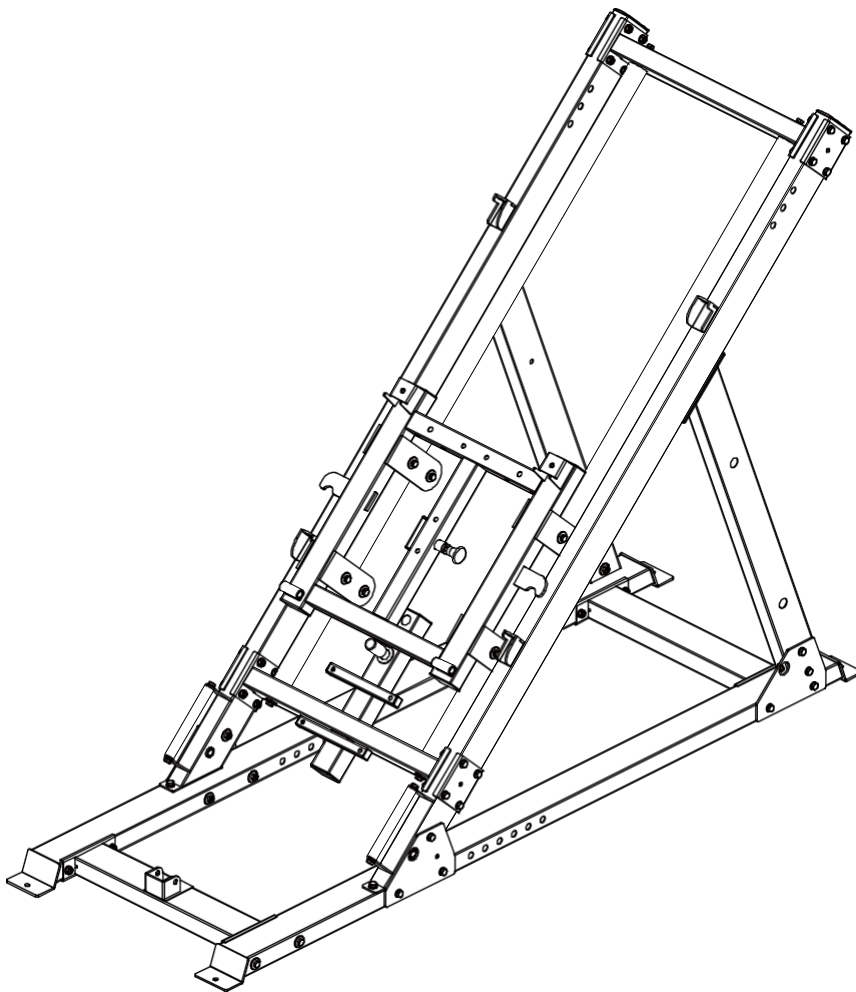

ASSEMBLY STEP 3 INSTRUCTIONS

1. Fix guide rod down fixed tube assembly part-18 on main frame use M10*70 hexagon bolt-12, $\phi 10$ flat washer-5 and M10 lock nut-6 and 100*130*4 link plate.
2. Fix slide rod assembly part-20 on guide rod down fixed tube assembly part-18 use M10*30 hexagon bolt-24, $\phi 10$ spring washer-15 and $\phi 30 \times \phi 10 \times 3$ big flat washer-4.
3. Put slide frame assembly part-21 into slide rod assembly part-20.
4. Fix guide rod fixed tube assembly part-19 on main frame use M10*70 hexagon bolt-12, $\phi 10$ flat washer-5 and M10 lock nut-6 and 100*130*4 link plate.
5. Fix slide rod assembly part-20 on guide rod fixed tube assembly part-19 use M10*30 hexagon bolt-24, $\phi 10$ spring washer-15 and $\phi 30 \times \phi 10 \times 3$ big flat washer-4.

ASSEMBLY STEP 4

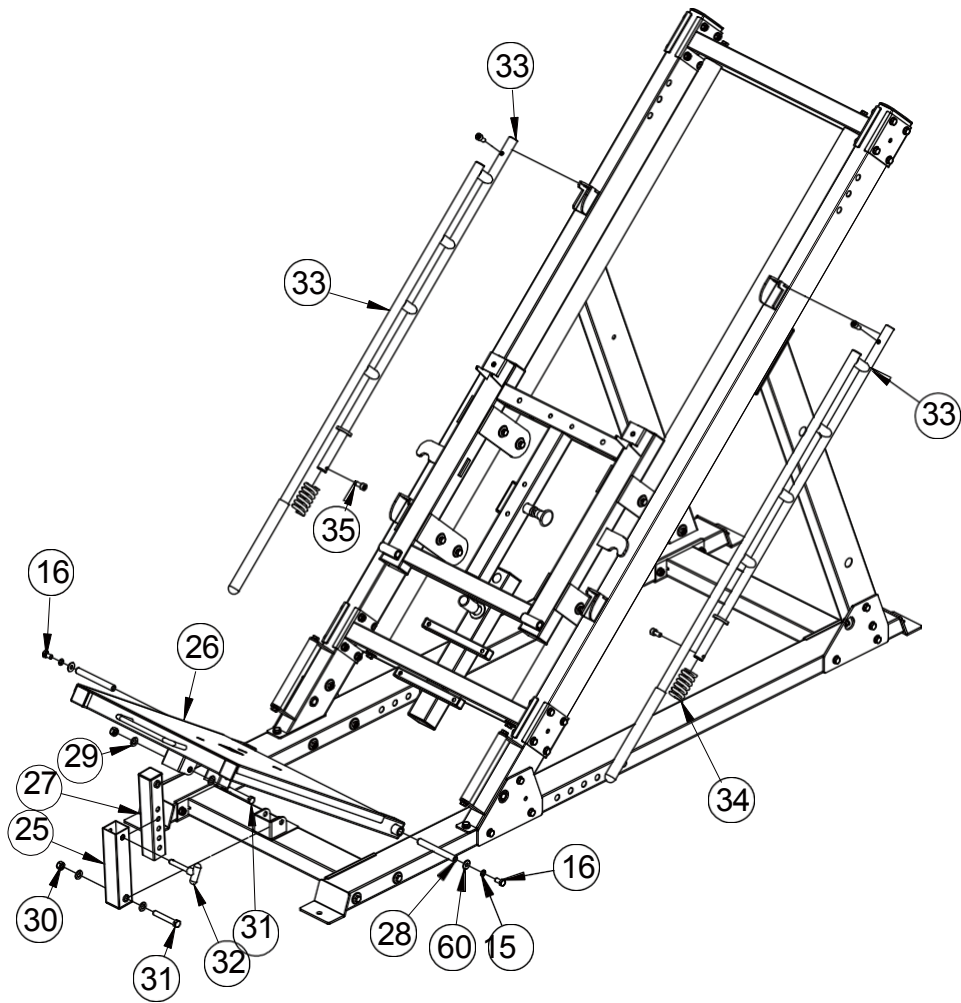

KEY NUMBER	DESCRIPTION OF PART	QUANTITY
15	Spring Washer $\phi 10$	4
16	Hexagon Bolt M10*20	4
25	Leg Press Adjust Outer Tube Assembly Part	1
26	Feet Plate	1
27	Leg Press Adjust Tube Assembly Part	1
28	Internal Thread Axle $\phi 15.9 \times 135$	2
29	Flat Washer $\phi 12$	4
30	Lock Nut M12	2
31	Hexagon Bolt M12*80	2
32	T Shape Pin	1
33	Limit Frame Assembly Part	2
34	Spring	2
35	Hexagon Socket Button Head Screws M10*20	4
60	Big Flat Washer $\phi 25 \times \phi 10 \times 2$	4

ASSEMBLY DRAWING

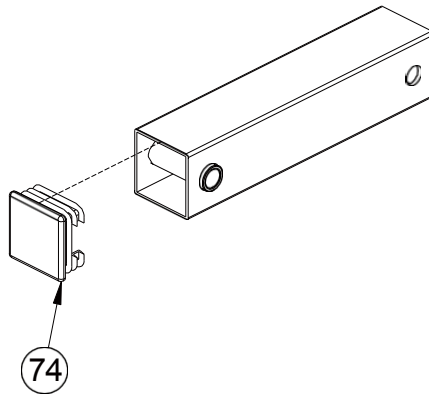

KEY NUMBER	DESCRIPTION OF PART	QUANTITY
74	74 Tube Plug $\phi 50 \times 50 \times 2$	1

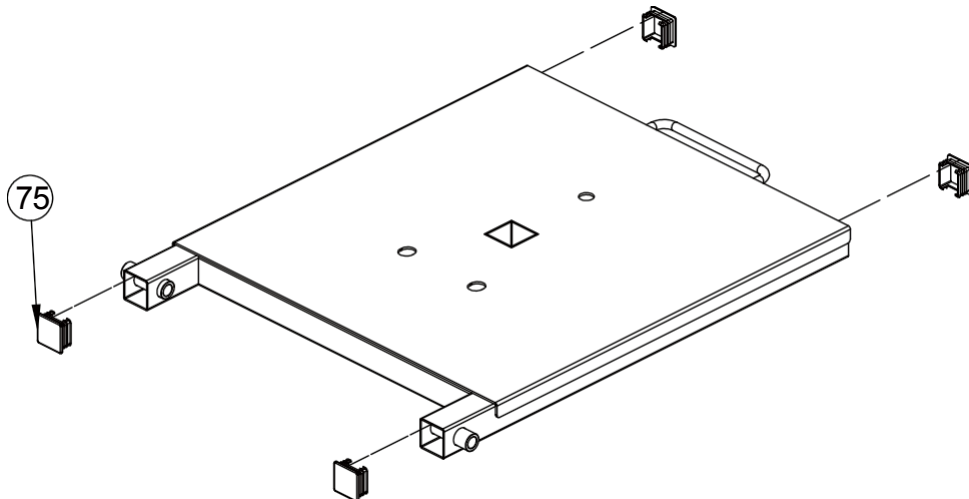

KEY NUMBER	DESCRIPTION OF PART	QUANTITY
75	Tube Plug $\phi 45 \times 45 \times 2$	4

ASSEMBLY DRAWING

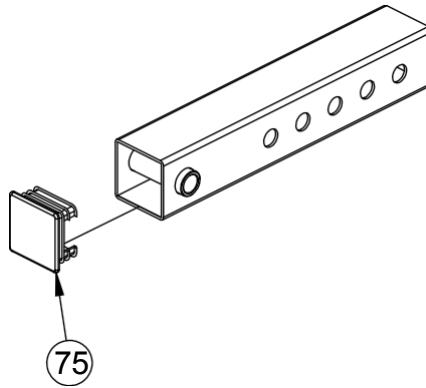

KEY NUMBER	DESCRIPTION OF PART	QUANTITY
75	Tube Plug $\phi 45 \times 45 \times 2$	4

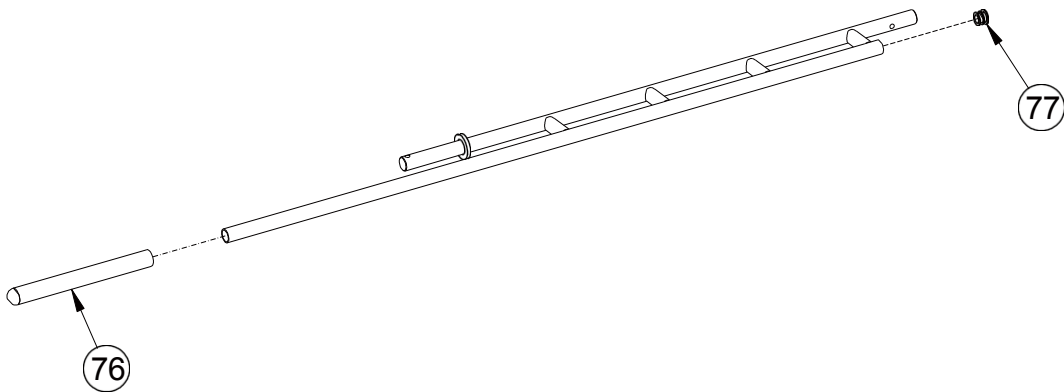

KEY NUMBER	DESCRIPTION OF PART	QUANTITY
76	Handle Cover $\phi 24.5 \times 280$	1
77	Round Plug $\phi 25 \times 2$	1

ASSEMBLY DRAWING

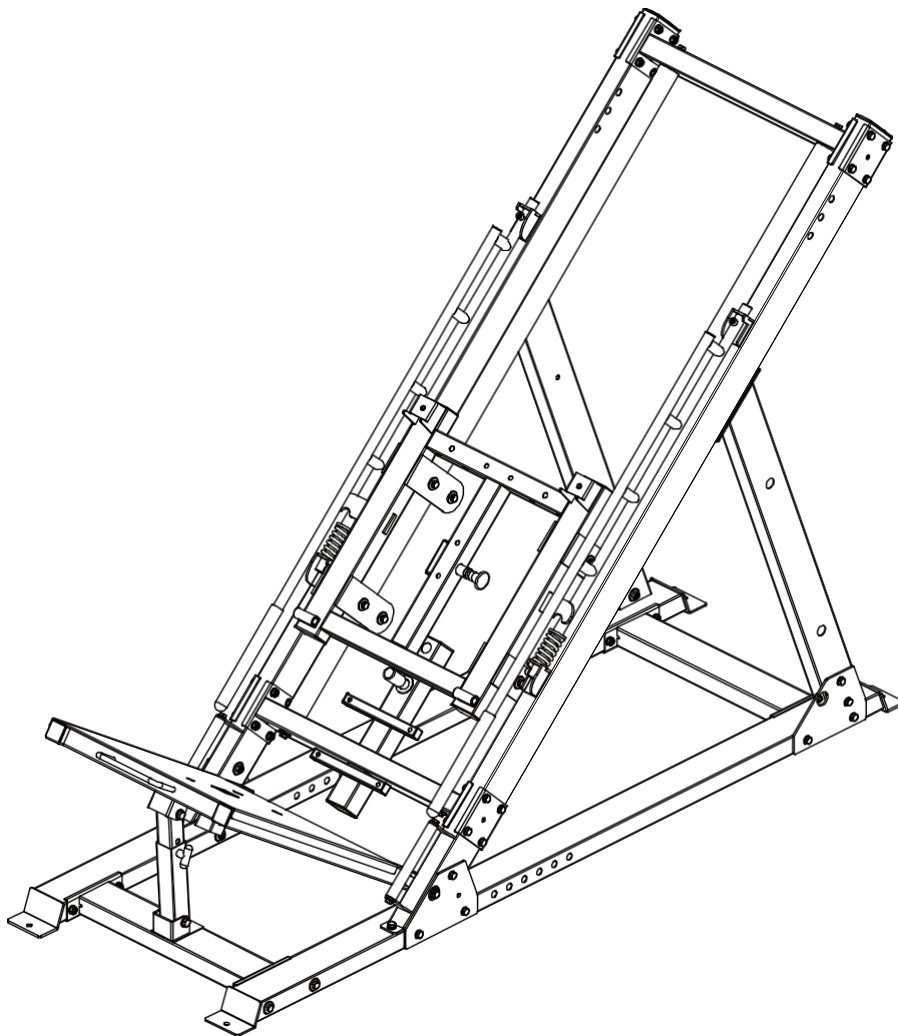

ASSEMBLY STEP 4 INSTRUCTIONS

1. Fix limit frame assembly part-33 on main frame use spring-34 and M10*20 hexagon socket button head screws-35.
2. Fix leg press adjust outer tube assembly part-25 on main frame use M12*80 hexagon bolt- 31, ϕ 12 flat washer-29, M12 lock nut-30.
3. Fix leg press adjust tube assembly part-27 on feet plate-26 use M12*80 hexagon bolt-31, ϕ 12 flat washer-29, M12 lock nut-30.
4. Fix feet plate-26 on main frame use M10*20 hexagon bolt-16, ϕ 10 spring washer-15, ϕ 25* ϕ 10*2 big flat washer-60 and ϕ 15.9*135 Internal thread axle.
5. Link leg press adjust outer tube assembly part-25 and leg press adjust tube assembly part-27 use t shape pin-32.

ASSEMBLY STEP 5

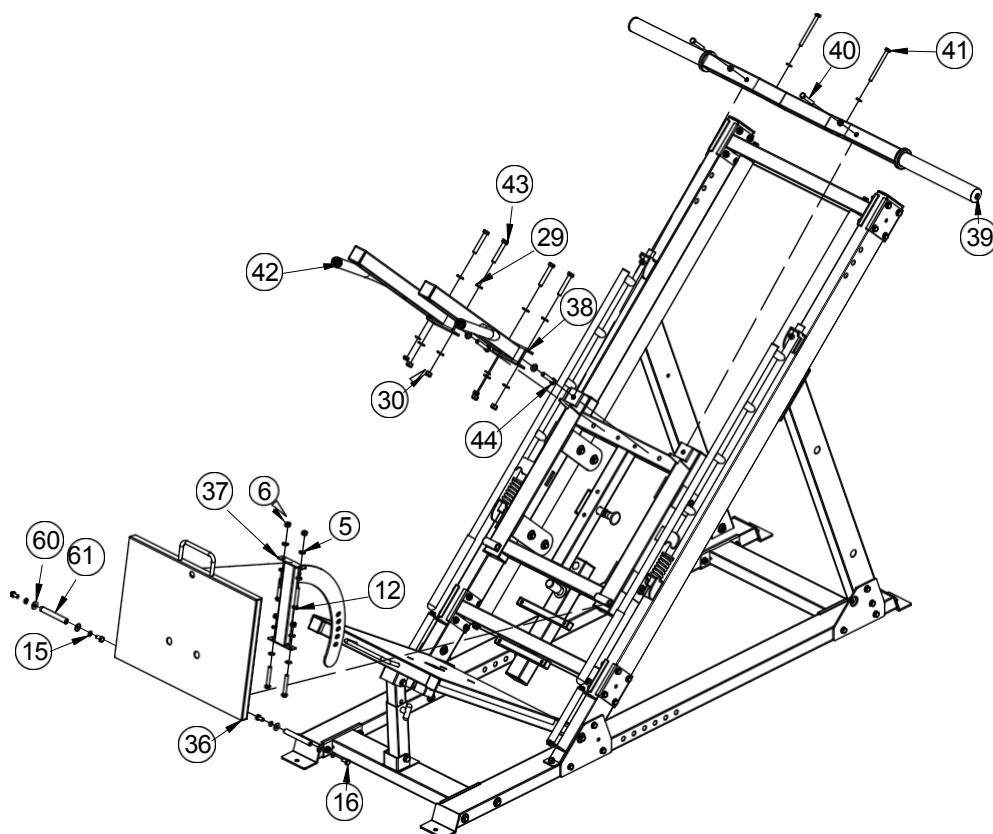

KEY NUMBER	DESCRIPTION OF PART	QUANTITY
5	Flat Washer $\phi 10$	14
6	Lock Nut M10	6
12	Hexagon Bolt M10*70	4
15	Spring Washer $\phi 10$	4
16	Hexagon Bolt M10*20	4
29	Flat Washer $\phi 12$	10
30	Lock Nut M12	4
36	Up Feet Plate Assembly Part	1
37	Regulating Fixing Tube Assembly Part	1
38	Shoulder Pads Frame-Right Assembly Part	1
39	Barbell Plate Holder Frame	1
40	Hexagon Bolt M10*65	2
41	Hexagon Bolt M10*115	2
42	Shoulder Pads Frame-Left Assembly Part	1
43	Hexagon Bolt M12*75	4
44	Hexagon Bolt M12*65	2
60	Big Flat Washer $\phi 25*\phi 10*2$	4
61	Internal Thread Axle $\phi 15.9*120$	2

ASSEMBLY DRAWING

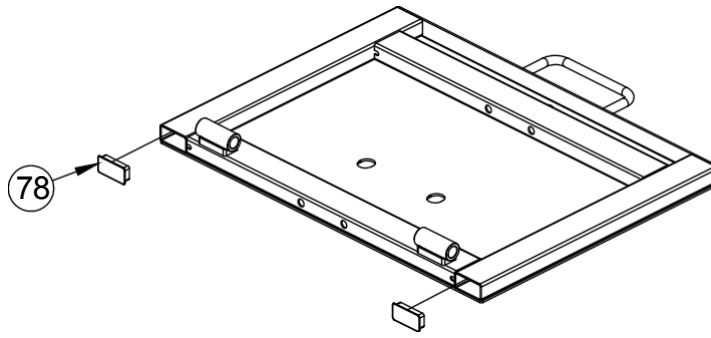

KEY NUMBER	DESCRIPTION OF PART	QUANTITY
78	Tube Plug $\phi 25 \times 25 \times 1.5$	2

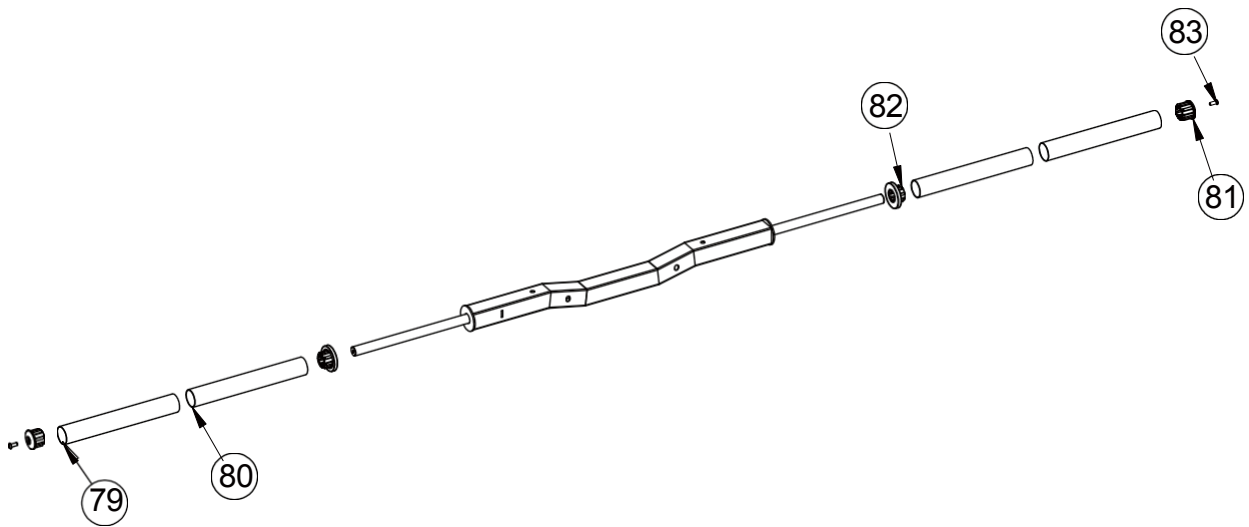

KEY NUMBER	DESCRIPTION OF PART	QUANTITY
79	$\phi 50 \times 345$ Stainless Steel Tube $\phi 49.5 \times 6$	2
80	$\phi 48 \times 344$ Inner Tube $\phi 48 \times 1.5$	2
81	End Cap $\phi 50 \times \phi 44.8 \times \phi 25.5$	2
82	Middle Cap $\phi 70 \times 44.8 \times \phi 25.5 \times 30$	2
83	Hexagon Socket Button Head Screws M8*20	2

ASSEMBLY DRAWING

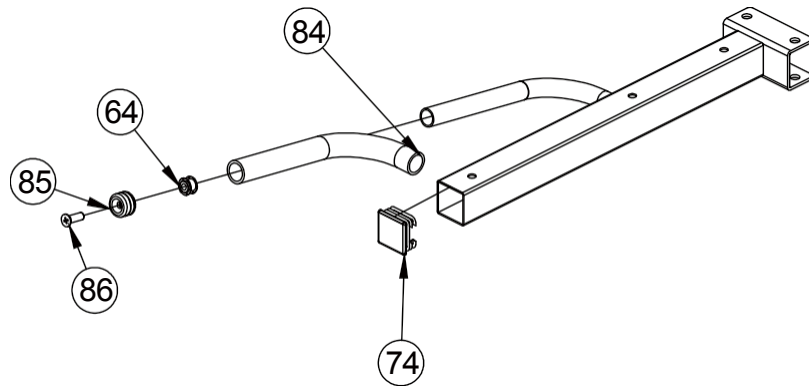

KEY NUMBER	DESCRIPTION OF PART	QUANTITY
64	Two Layer Spring Nut $\phi 23\text{-M}10$	1
74	Tube Plug $\phi 50\text{*}50\text{*}2$	1
84	Handle Cover $\phi 32\text{*}310$	1
85	Retaining Ring $\phi 31.5\text{*}\phi 25.5$	1
86	Cross Recessed Countersunk Head Screw M10*25	1

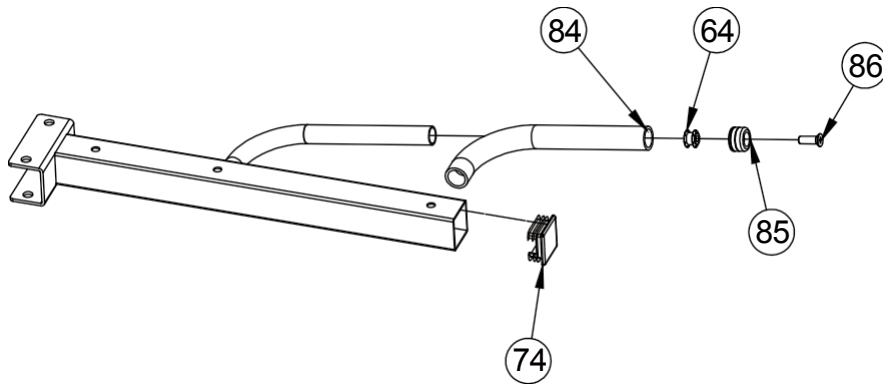

KEY NUMBER	DESCRIPTION OF PART	QUANTITY
64	Two Layer Spring Nut $\phi 23\text{-M}10$	1
74	Tube Plug $\phi 50\text{*}50\text{*}2$	1
84	Handle Cover $\phi 32\text{*}310$	1
85	Retaining Ring $\phi 31.5\text{*}\phi 25.5$	1
86	Cross Recessed Countersunk Head Screw M10*25	1

ASSEMBLY DRAWING

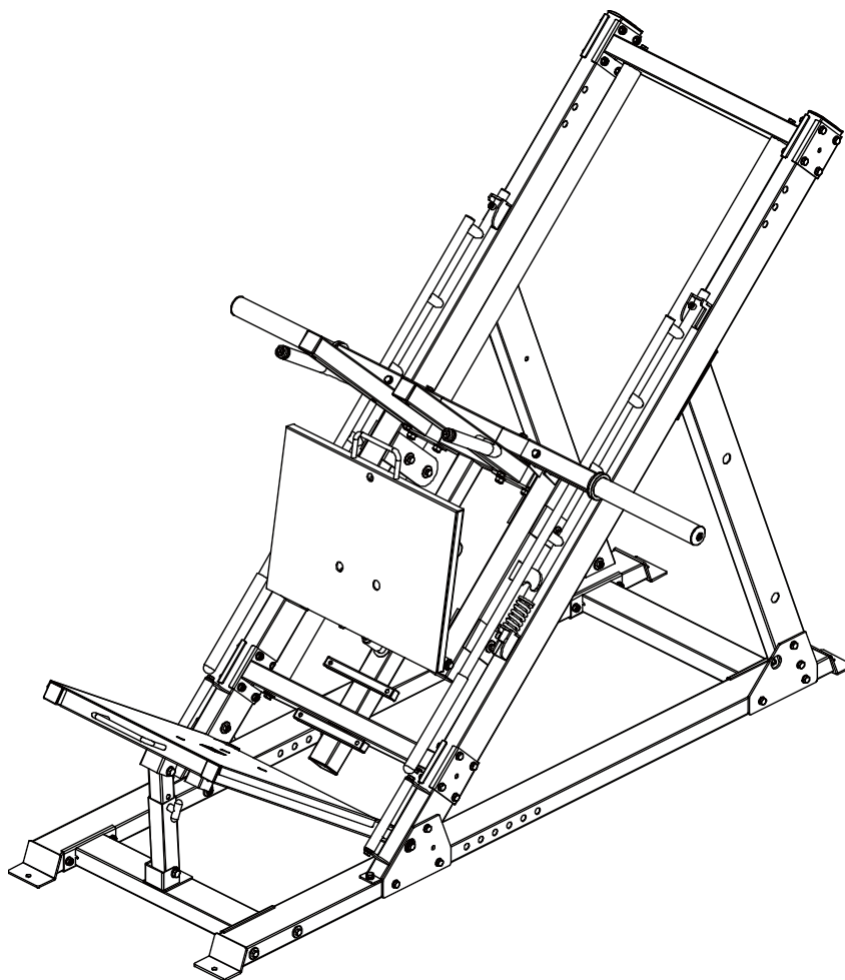

ASSEMBLY STEP 5 INSTRUCTIONS

1. Fix shoulder pads frame-left assembly part-42 and shoulder pads frame-right assembly part-38 on main frame use M12*75 hexagon bolt-43, $\phi 12$ flat washer-29, M12 lock nut-30 and M12*65 hexagon bolt-44.
2. Fix barbell plate holder frame-39 on main frame use M10*65 hexagon bolt-40, M10*115 hexagon bolt-41, $\phi 10$ flat washer-5 and M10 lock nut-6.
3. Fix barbell plate holder frame-39 on up feet plate assembly part-36 use M10*70 hexagon bolt-12, $\phi 10$ flat washer-5 and M10 lock nut-6.
4. Fix up feet plate assembly part-36 on main frame use M10*20 hexagon bolt-16, $\phi 10$ spring washer-15, $\phi 25 \times \phi 10 \times 2$ big flat washer-60 and $\phi 15.9 \times 120$ Internal thread axle-61.

ASSEMBLY STEP 6

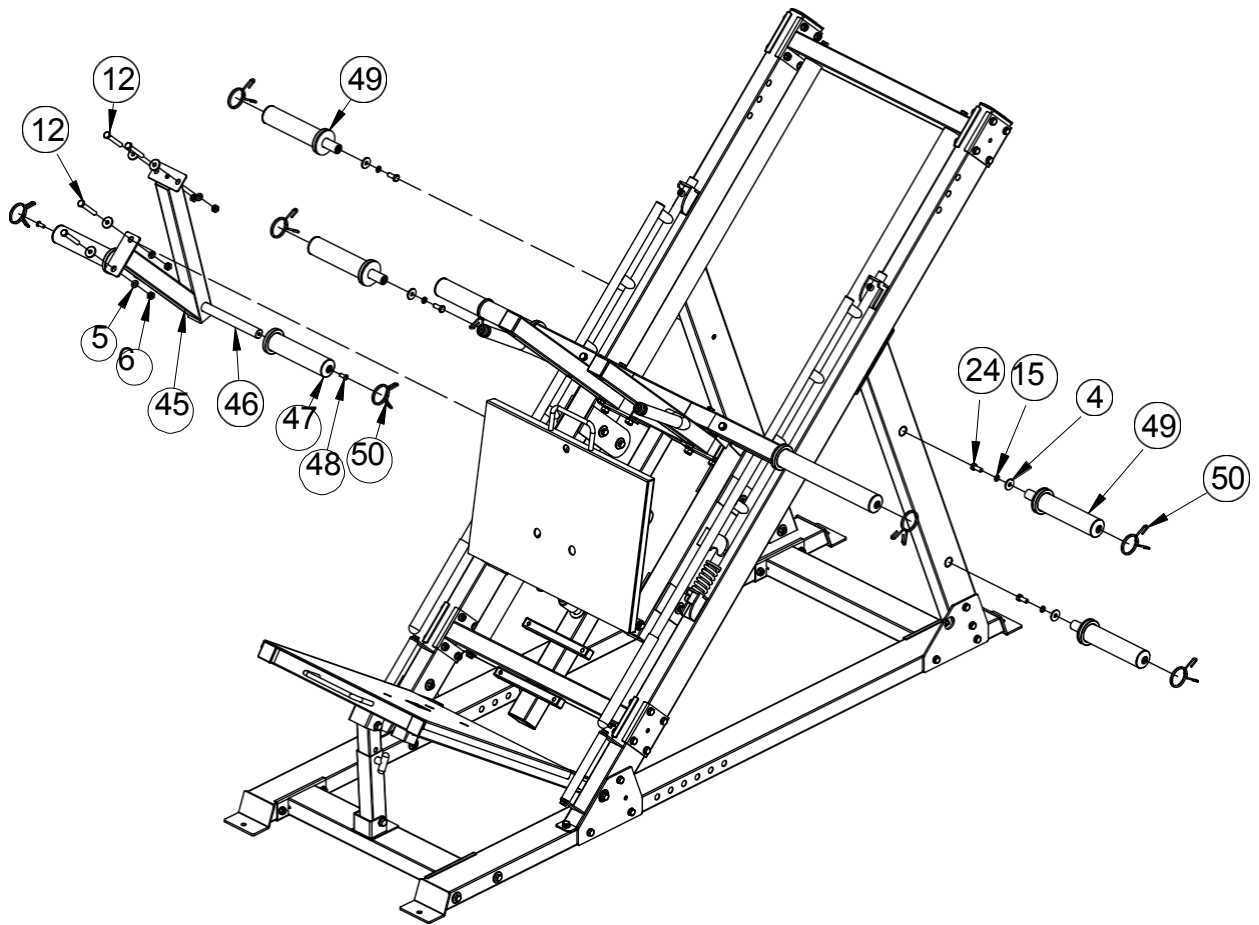

KEY NUMBER	DESCRIPTION OF PART	QUANTITY
4	Big Flat Washer $\phi 30 \times \phi 10 \times 3$	8
5	Flat Washer $\phi 10$	4
6	Lock Nut M10	4
12	Hexagon Bolt M10*70	4
15	Spring Washer $\phi 10$	4
24	Hexagon Bolt M10*30	4
45	Lifting Frame Assembly Part	1
46	Barbell Inner Rod	1
47	Barbell Plate Holder	2
48	Hexagon Socket Button Head Screws M8*20	2
49	Barbell Plate Holder	4
50	Spring Collar	8

ASSEMBLY DRAWING

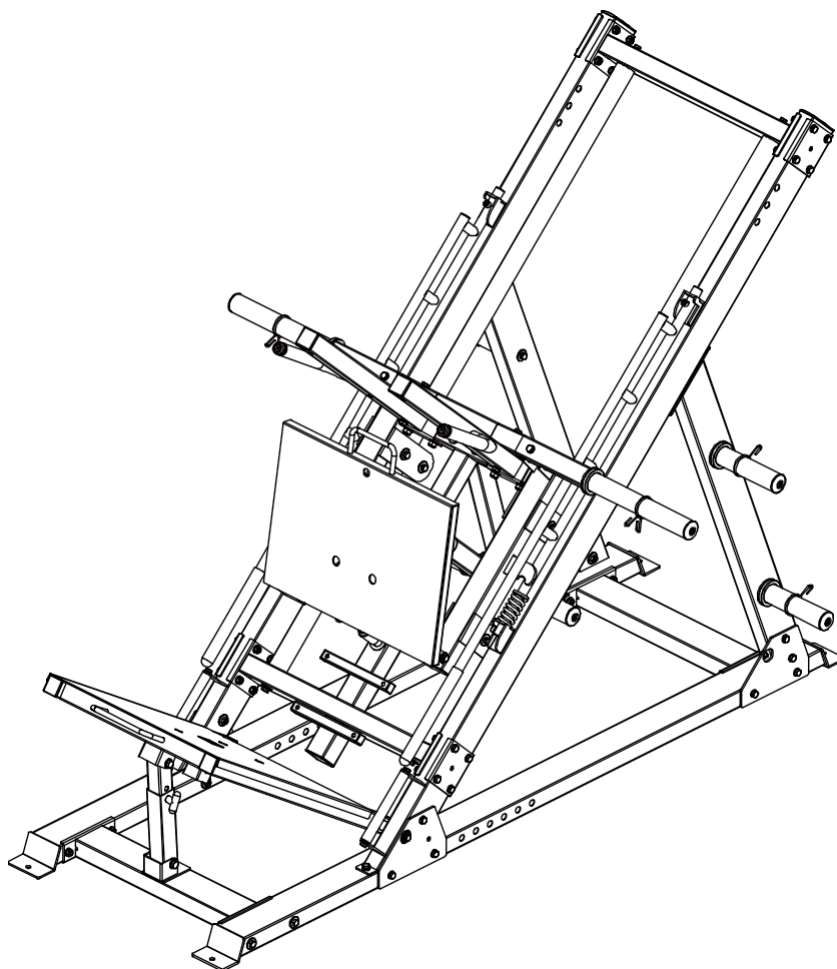

ASSEMBLY STEP 6 INSTRUCTIONS

1. Fix lifting frame assembly part-45 on frame use M10*70 hexagon bolt-12, $\phi 10$ flat washer-5, $\phi 30 \times \phi 10 \times 3$ big flat washer-4 and vM10 lock nut-6.
2. Fix barbell inner rod-46 on lifting frame assembly part-45 use M8*20 hexagon socket button head screws-48 and barbell plate holder-47.
3. Fix barbell plate holder-49 on main frame use M10*30 hexagon bolt-24, $\phi 10$ spring washer- 15 and $\phi 30 \times \phi 10 \times 3$ big flat washer-4.
4. Put spring collar on main frame.

ASSEMBLY STEP 7

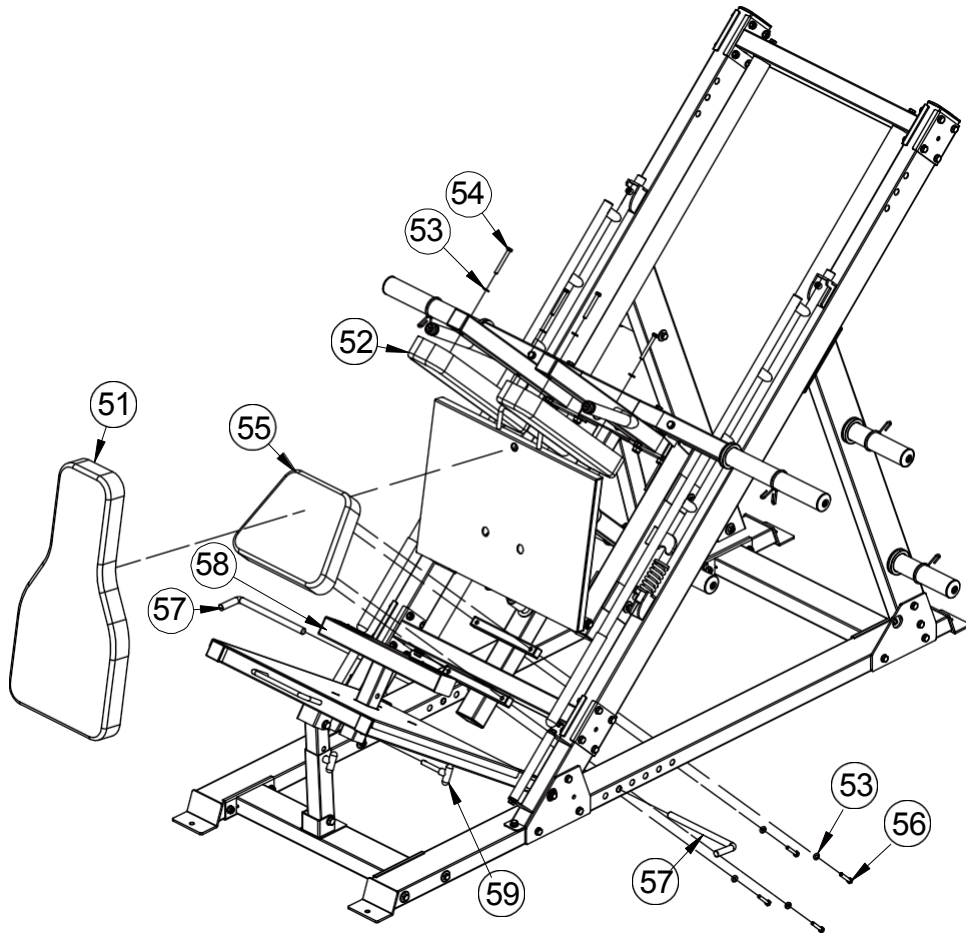

KEY NUMBER	DESCRIPTION OF PART	QUANTITY
51	Back Pad	1
52	Shoulder Pad	2
53	Flat Washer $\varphi 8$	8
54	Hexagon Bolt M8*70	4
55	Seat Pad	1
56	Hexagon Bolt M8*45	4
57	Band Peg	2
58	Feet Brick Frame	1
59	T Shape Pin	1

ASSEMBLY DRAWING

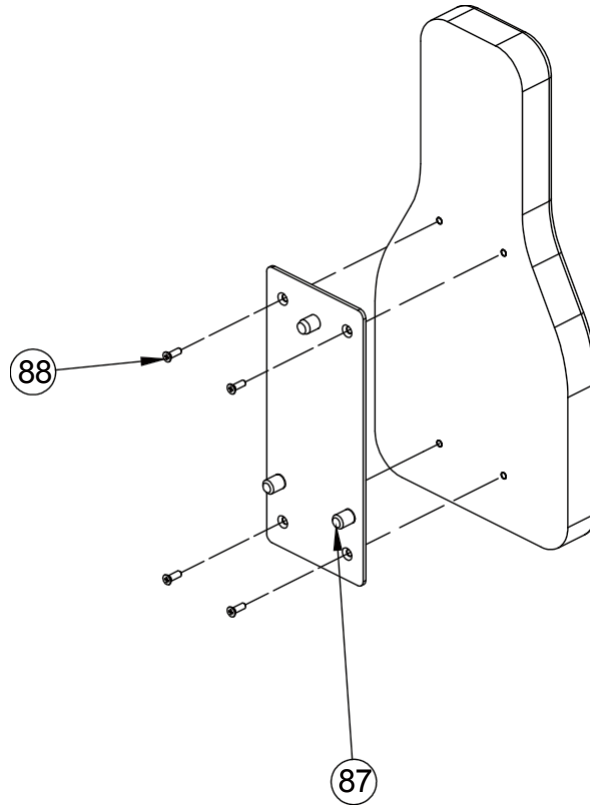

KEY NUMBER	DESCRIPTION OF PART	QUANTITY
87	Back Pad Fixing Plate	1
88	Cross Recessed Countersunk Head Screw M8*20	4

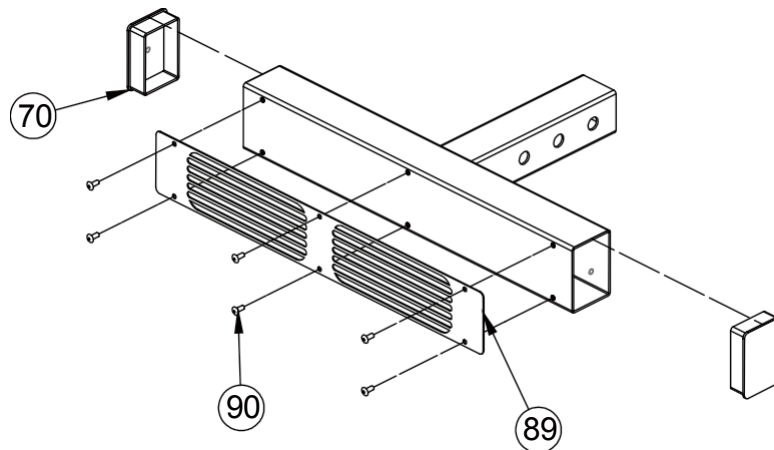

KEY NUMBER	DESCRIPTION OF PART	QUANTITY
70	Plug 50*70*2	2
89	Anti-Slip Sheet	2
90	Flat Round Head Blind Rivet 4*10	6

ASSEMBLY DRAWING

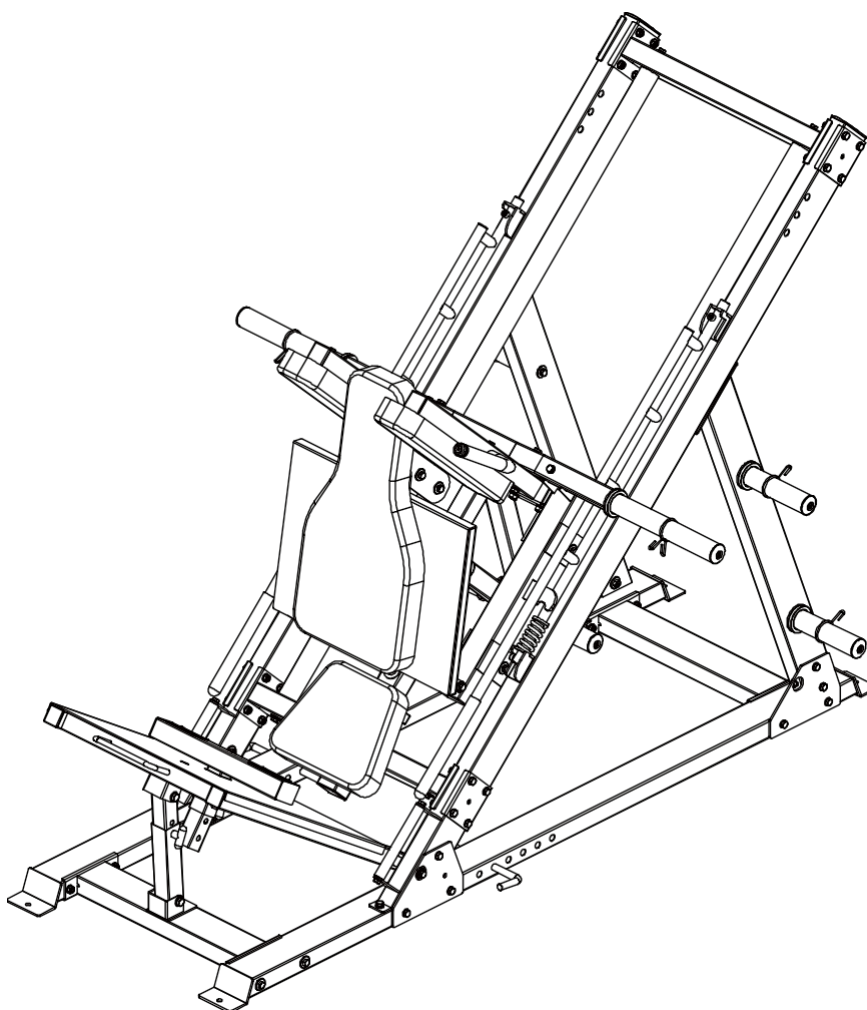

ASSEMBLY STEP 7 INSTRUCTIONS

1. Fix seat pad-55 on main frame use M8*45 hexagon bolt-56 and $\phi 8$ flat washer-53.
2. Fix shoulder pad-52 on main frame use M8*70 hexagon bolt-54 and $\phi 8$ flat washer-53.
3. Put back pad-51 on up feet plate assembly part-36.
4. Put feet brick frame-58 on down feet plate-26 lock use $\phi 12*70$ t shape pin-59.
5. Put band peg-57 on main frame.