

FORCE^{USA}

THE TRUSTED NAME IN STRENGTH EQUIPMENT

OWNER'S MANUAL **F-G12**

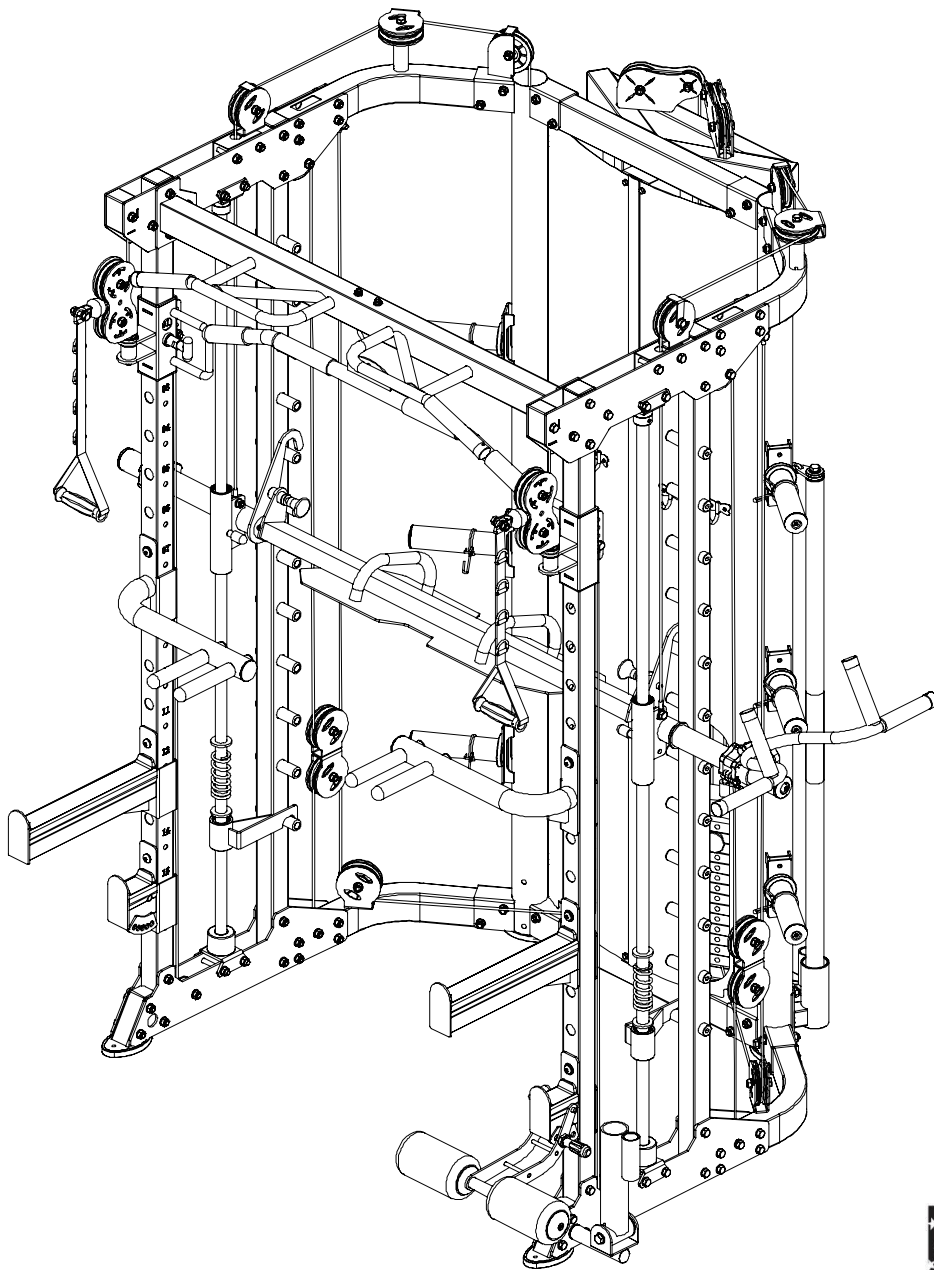

CAUTION!

Read all precautions and instructions in this manual before using this equipment.



DESIGNED
IN THE USA

Contents

Parts list	3-5
Assembly step 1	6-7
Assembly step 2	8-10
Assembly step 3	11-12
Assembly step 4	13-14
Assembly step 5	15-16
Assembly step 6	17-18
Assembly step 7	19-20
Assembly step 8	21-22
Assembly step 9	23-24
Assembly step 10	25-26
Assembly step 11	27-28

Parts list

No.	Description	Note	Qty.
1	connection tube		1
2	upright frame left		1
3	upright frame right		1
4	bending tube left		1
5	bending tube right		1
6	upper connection tube		1
7	upper bending tube right		1
8	upper bending tube left		1
9	hexagon bolt	M10x75	54
10	lock nut	M10	100
11	washer	Φ10	210
11	washer	Φ10	1
12	chin up bar		4
13	upper plate		1
14	pulley frame tube right		1
15	pulley frame tube left		2
16	upright tube		1
17	tube with hole right		1
18	tube with hole left		4
19	lower plate		1
20	sliding tube right		1
21	sliding tube left		2
22	foot tube cover		2
23	end tube		14
24	hexagon bolt	M10x80	2
26	upper base		2
27	guide rod	Φ25x1850	2
28	lock sleeve		2
29	sliding sleeve		2
30	rubber pad with groove	Φ60xΦ26x45	2
31	safety hook right		1
32	safety hook left		1
33	hexagon bolt	M10x90	8
34	socket set screw	M8x10	2
35	end cap		2

No.	Description	Note	Qty.
36	check ring		2
37	pipe	Φ50x310xT0.5	2
38	button head socket screw	M12x40	2
39	spring washer	Φ12	2
40	washer	Φ12	2
41	barbell rod		1
42	inner pipe	Φ48x298x2.5T	2
43	rubber pad	Φ60xΦ26x25	2
44	rubber pad	Φ60xΦ26x42	4
45	guide rod hollow	Φ25x1955	4
46	reinforcing plate		4
47	weight stack		2
48	hexagon bolt	M10x20	8
49	wire	Φ5x2745mm	2
50	pulley	Φ95	20
51	pulley plate		4
52	hexagon bolt	M10x45	14
53	hexagon bolt	M10x50	4
54	hexagon bolt	M10x25	7
55	weight		2
56	wire	Φ5x4095mm	2
57	"-" shaped pulley frame		2
58	pulley spacer sleeve	Φ20x10.5xL20.5	16
59	pulley	Φ50	6
60	wire		2
61	barbell plate holder		6
62	connection strap		1
63	shield left		1
64	shield right		1
65	hexagon bolt	M6x16	10
66	washer	Φ6	10
67	hook		4
68	"+" slotted countersunk head bolt	M4x12	8
69	lock nut	M4	8
70	hexagon bolt	M8x20	12

No.	Description	Note	Qty.
71	washer	Φ8	12
72	core trainer		1
73	powder metallurgy sleeve		2
74	barbell rod cup		1
75	big washer	Φ25x10x2.0	1
76	hexagon bolt	M10x95	2
77	dip bar left		1
78	dip bar right		1
79	barbell rod holder right		1
80	barbell rod holder left		1
81	barbell rod holder short left		1
82	barbell rod holder short right		1
83	long bar		1
84	ship rod		1
85	hand belt		2
86	pull lift device		1
87	T shape pin	Φ10x100	1
88	leg curl tube		1
89	barbell rod ring		2
90	selector rod		2
91	weight pin		2
92	footplate		1



Assembly step 1

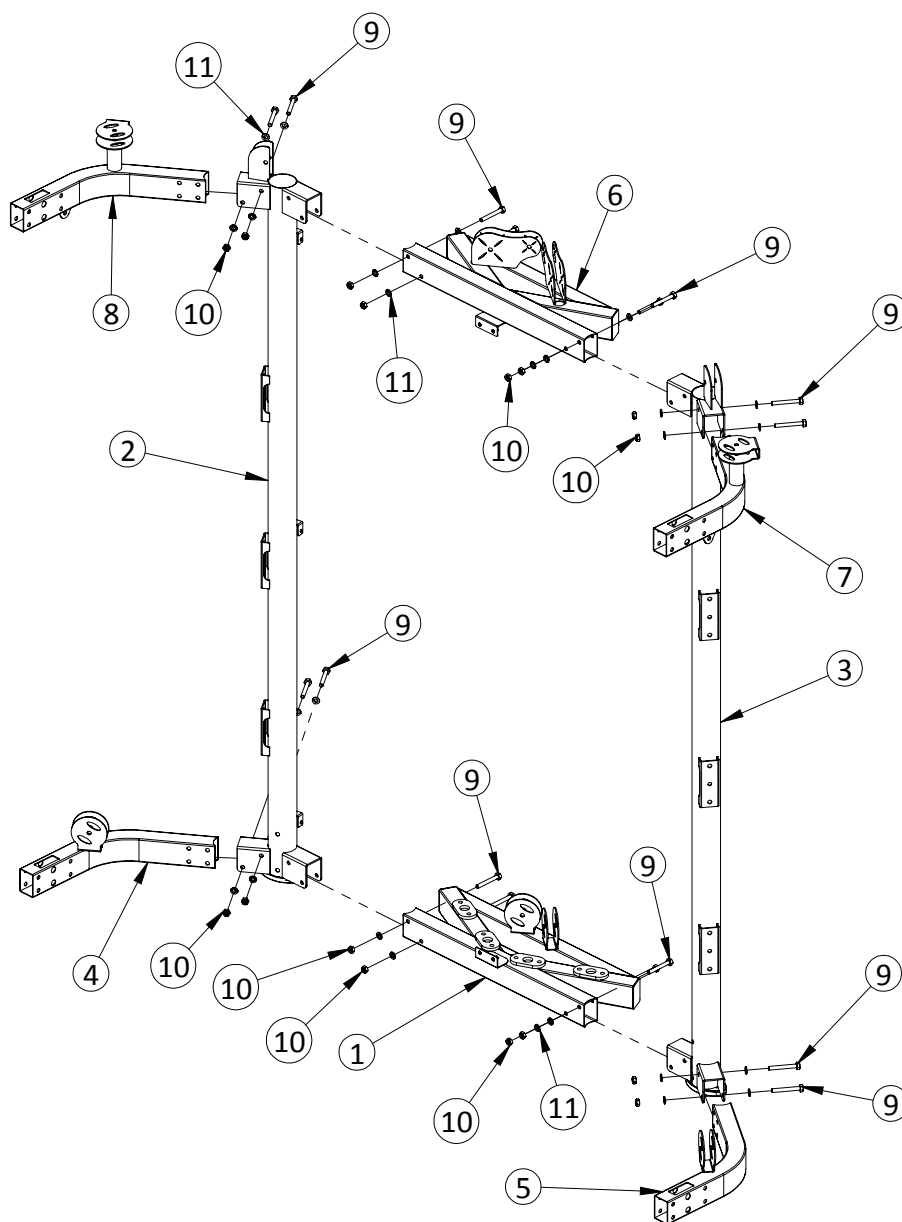

No.	Description	Note	Qty.
1	connection tube		1
2	upright frame left		1
3	upright frame right		1
4	bending tube left		1
5	bending tube right		1
6	upper connection tube		1
7	upper bending tube right		1
8	upper bending tube left		1
9	hexagon bolt	M10x75	16
10	lock nut	M10	16
11	washer	Φ10	32

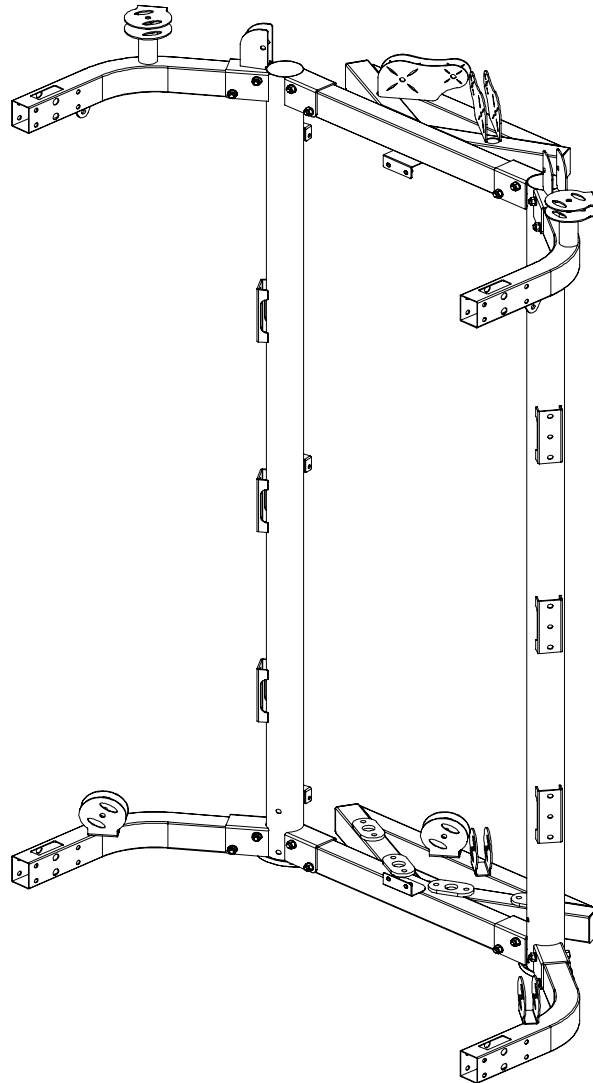

- 1 Fix bending tube left-4 fastening on upright frame left-2 using M10x75 hexagon bolt-9, Φ 10 washer-11 and M10 lock nut-10
- 2 Fix bending tube right-5 fastening on upright frame right-3 using M10x75 hexagon bolt-9, Φ 10 washer-11 and M10 lock nut-10
- 3 Fix connection tube-1 fastening with bending tube left-4, bending tube right-5 using M10x75 hexagon bolt-9, Φ 10 washer-11 and M10 lock nut-10
- 4 Fix upper connection tube-6 fastening on upright frame using M10x75 hexagon bolt-9, Φ 10 washer-11 and M10 lock nut-10
- 5 Fix upper bending tube left-8 fastening on upright frame left-2 using M10x75 hexagon bolt-9, Φ 10 washer-11 and M10 lock nut-10
- 6 Fix upper bending tube right-7 fastening on upright frame right-3 using M10x75 hexagon bolt-9, Φ 10 washer-11 and M10 lock nut-10

Assembly step 2

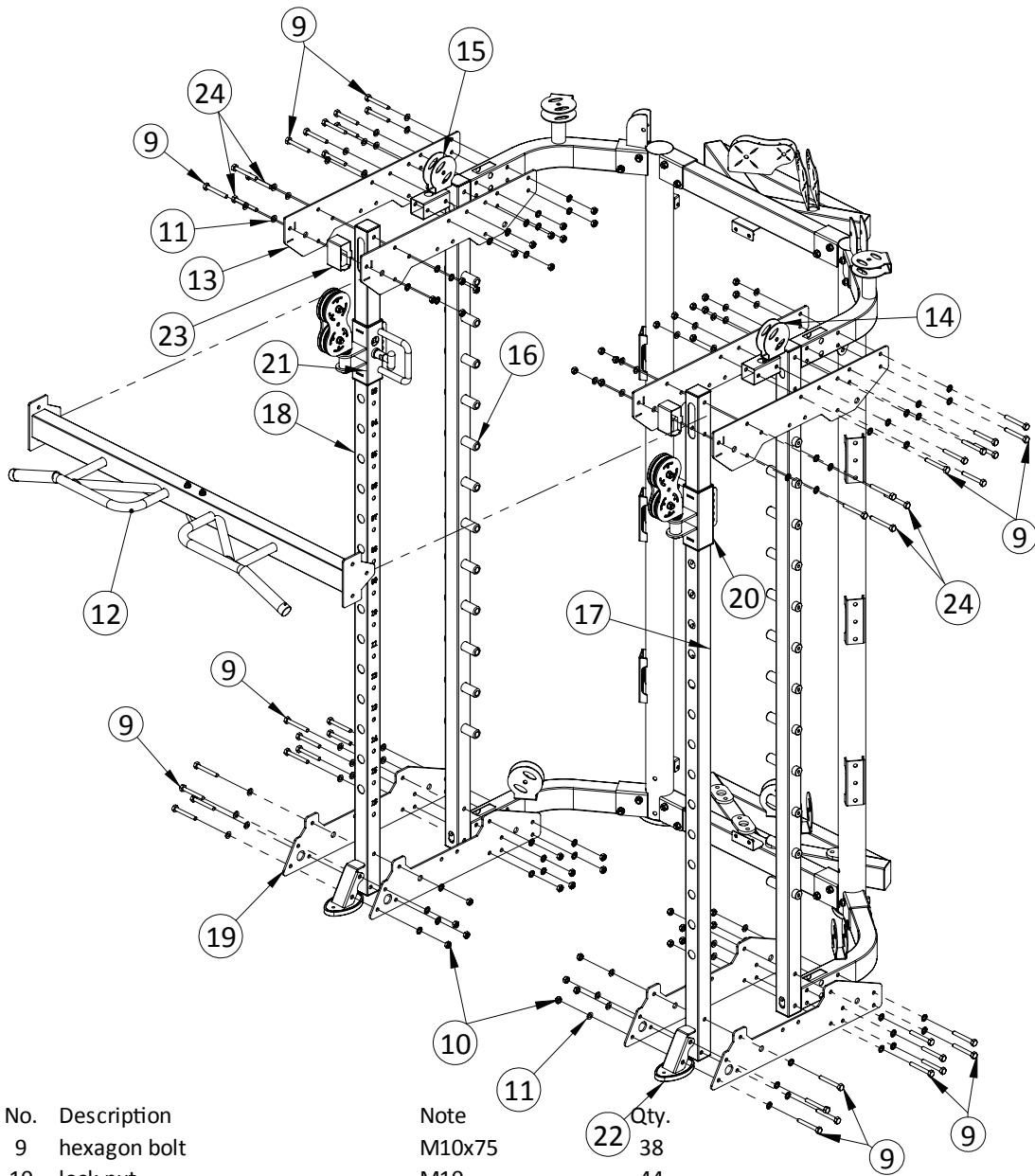

No.	Description	Note	Qty.
9	hexagon bolt	M10x75	38
10	lock nut	M10	44
11	washer	Φ10	88
12	chin up bar		1
13	upper plate		4
14	pulley frame tube right		1
15	pulley frame tube left		1
16	upright tube		2
17	tube with hole right		1
18	tube with hole left		1
19	lower plate		4
20	sliding tube right		1
21	sliding tube left		1
22	foot tube cover		2
23	end tube		2
24	hexagon bolt	M10x80	6

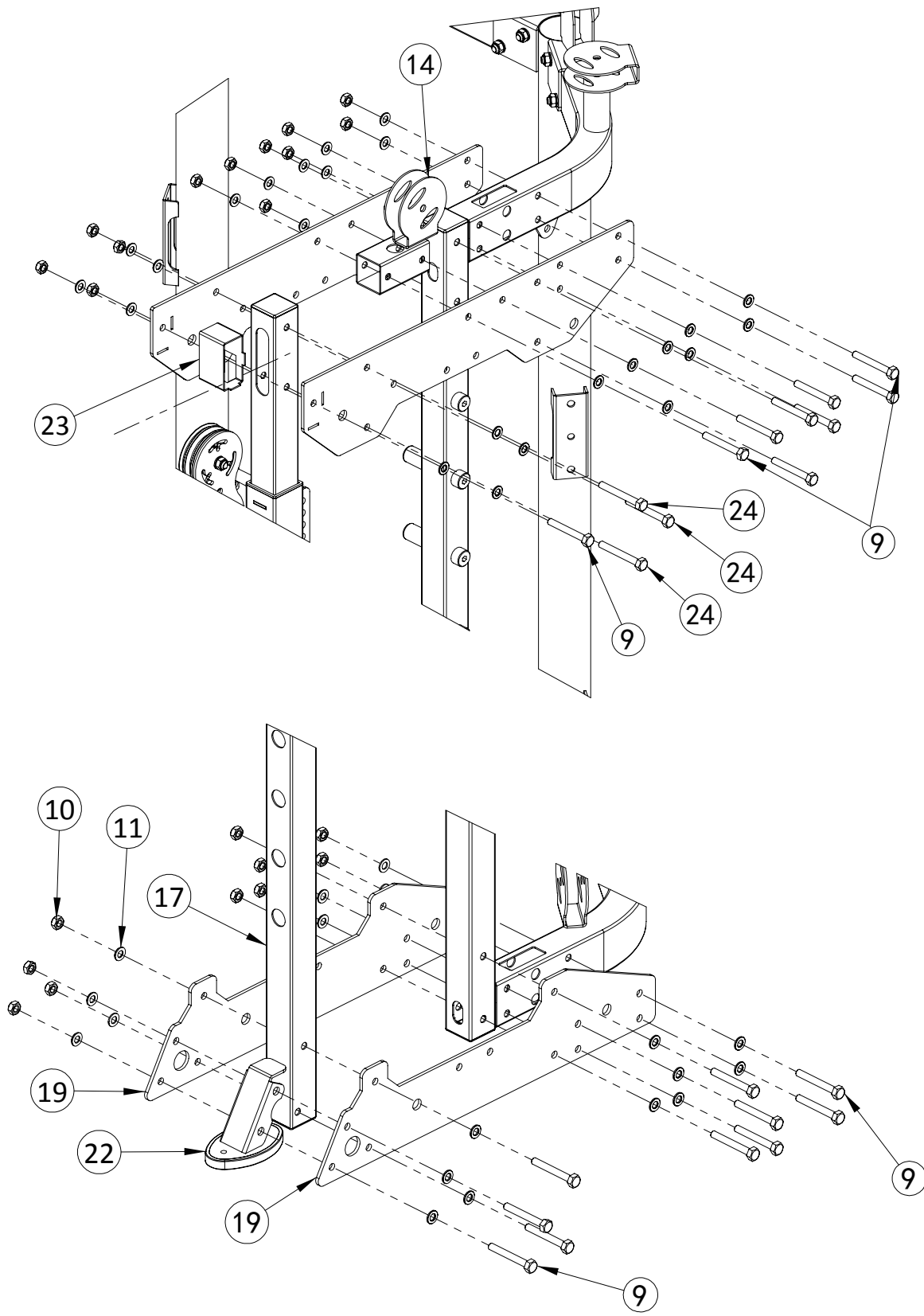

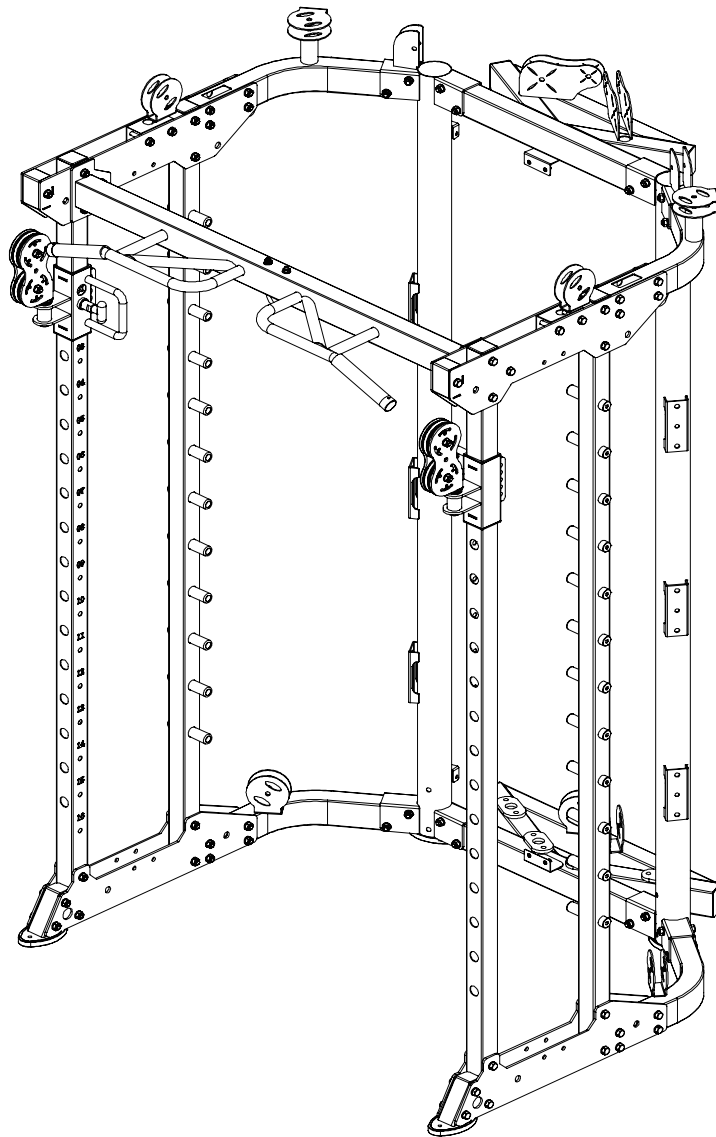

- 1 Fix sliding tube left-21 on tube with hole left-18
- 2 Fix sliding tube right on tube with hole right-17
- 3 Fix upright tube-16 and tube with hole left-18 fastening on assembly step-1 using M10x75 hexagon bolt-9, Φ 10 washer-11, M10 lock nut-10, upper plate-13 and lower plate-19
- 4 Fix pulley frame tube right-14 and pulley frame tube left-15 fastening on upper plate-13 using M10x75 hexagon bolt-9, Φ 10 washer-11 and M10 lock nut-10
- 5 Fix end tube-23 fastening on upper plate-13 using M10x75 hexagon bolt-9, Φ 10 washer-11 and M10 lock nut-10
- 6 Fix foot tube cover-22 fastening on lower plate-19 using M10x75 hexagon bolt-9, Φ 10 washer-11 and M10 lock nut-10
- 7 Fix chin up bar-12 fastening on upper plate-13 using M10x80 hexagon bolt-24, Φ 10 washer-11 and M10 lock nut-10

Assembly step 3

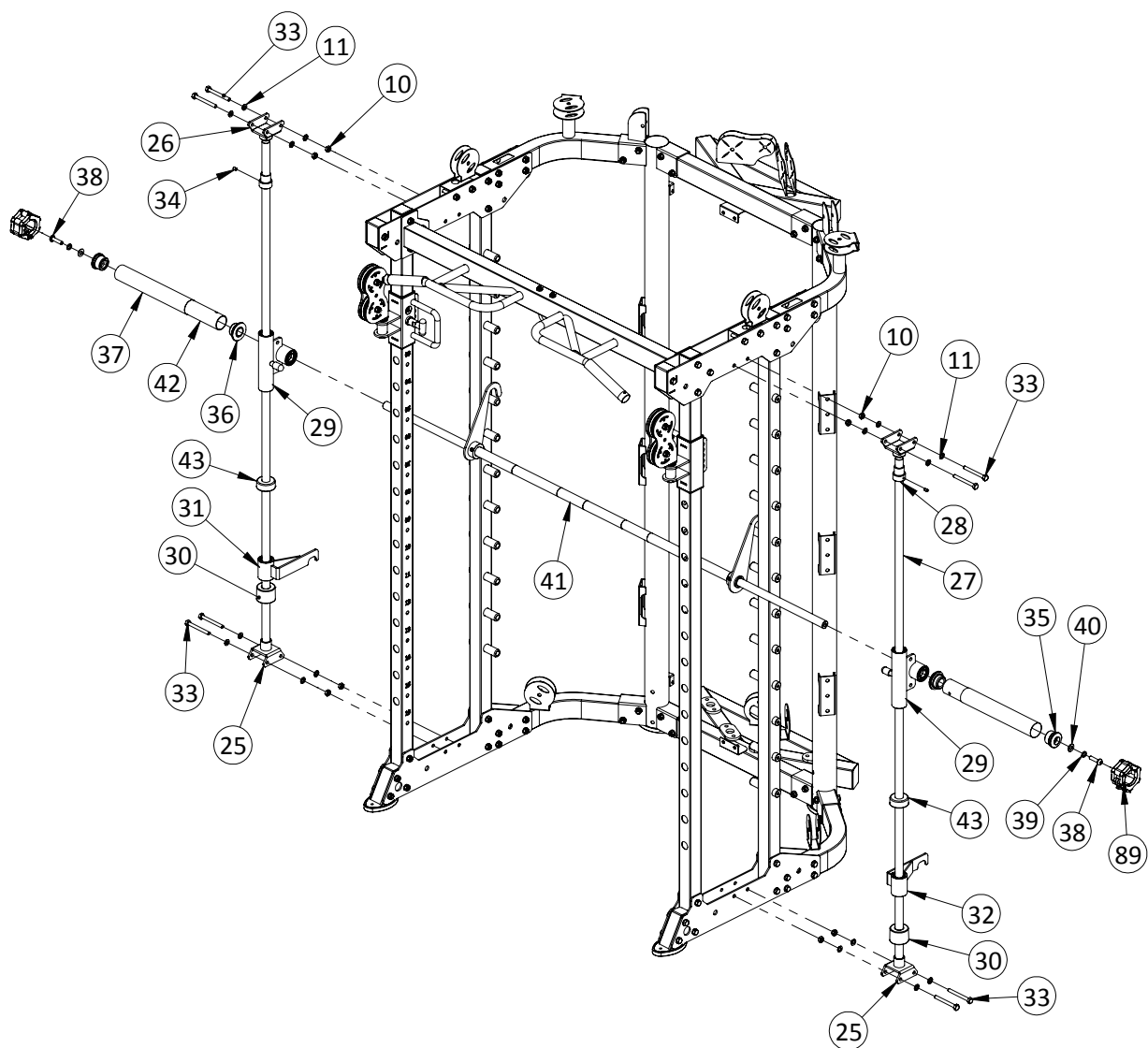

No.	Description	Note	Qty.	No.	Description	Note	Qty.
10	lock nut	M10	8	34	socket set screw	M8x10	2
11	washer	Φ10	16	35	end cap		2
25	lower base		2	36	check ring		2
26	upper base		2	37	pipe	Φ50x310xT0.5	2
27	guide rod	Φ25x1850	2	38	button head socket screw	M12x40	2
28	lock sleeve		2	39	spring washer	Φ12	2
29	sliding sleeve		2	40	washer	Φ12	2
30	rubber pad with groove	Φ60xΦ26x45	2	41	barbell rod		1
31	safety hook right		1	42	inner pipe	Φ48x298x2.5T	2
32	safety hook left		1	43	rubber pad	Φ60xΦ26x25	2
33	hexagon bolt	M10x90	8	89	barbell rod ring		2

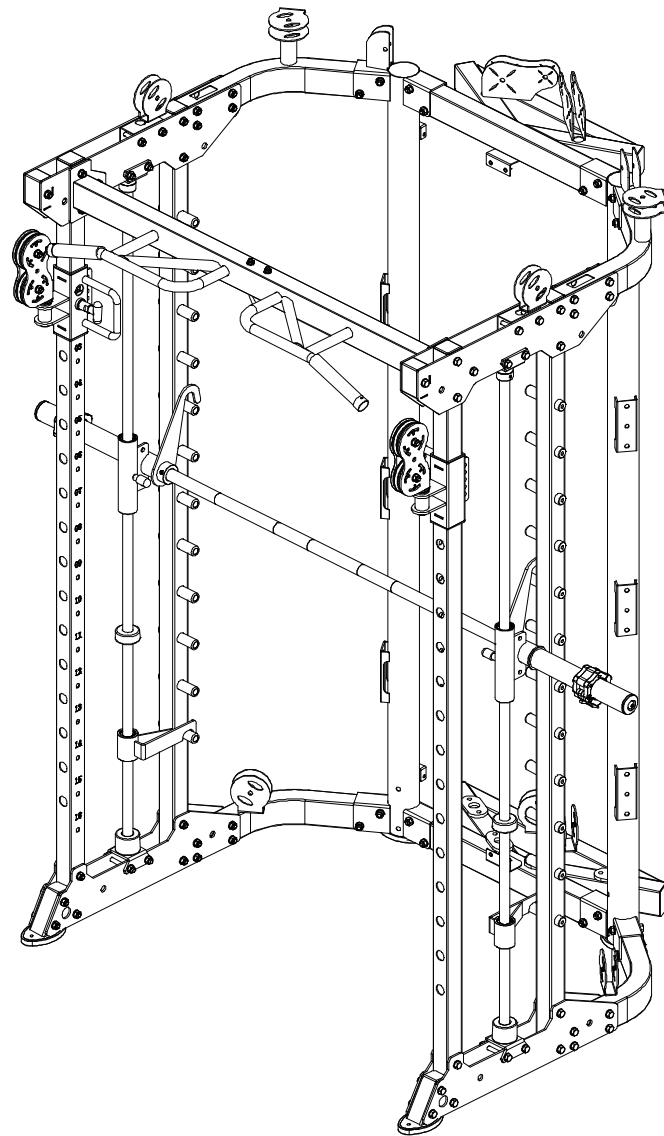

- 1 Fix lower base-25 fastening on lower plate using M10x90 hexagon bolt-33, Φ 10 washer-11 and M10 lock nut-10
- 2 Fix upper base-26 fastening on upper plate using M10x90 hexagon bolt-33, Φ 10 washer-11 and M10 lock nut-10
- 3 Guide rod in turn through lock sleeve-28, sliding sleeve-29, rubber pad-43, safety hook left-32 and rubber pad with groove-30 fastening on base using M8x10 socket set screw-34
- 4 Barbell rod-41 in turn through sliding sleeve-29, check ring-36, inner pipe-42, pipe-37 and end cap-35 fastening using M12x40 button head socket screw-38, Φ 12 spring washer-39 and Φ 12 washer-40, then fit on barbell clamp collar-89
- 5 Guide rod in turn through lock sleeve-28, sliding sleeve-29, rubber pad-43, safety hook right-31 and rubber pad with groove-30 fastening on base using M8x10 socket set screw-34

Assembly step 4

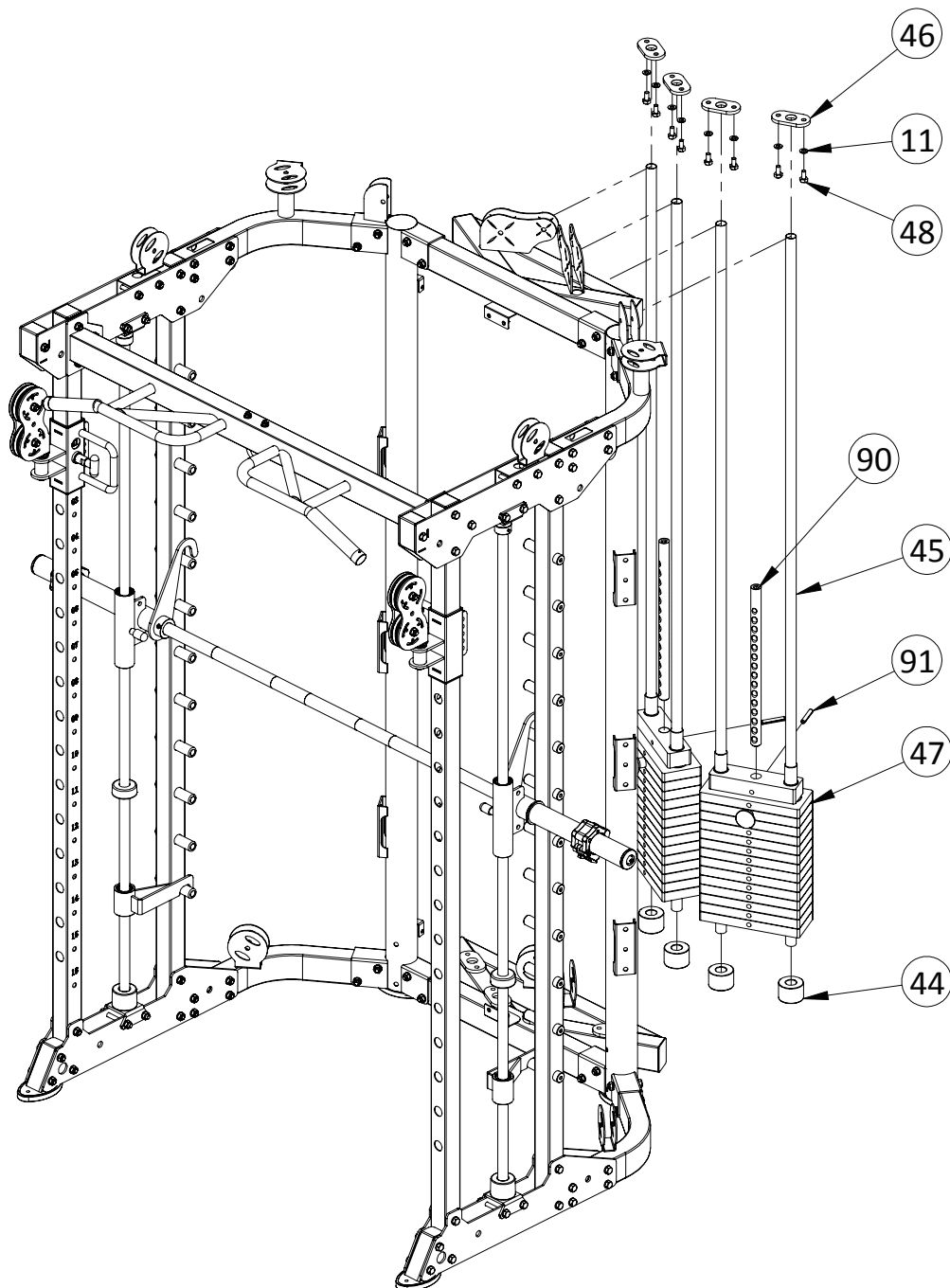

No.	Description	Note	Qty.
11	washer	Φ10	8
44	rubber pad	Φ60xΦ26x42	4
45	guide rod hollow	Φ25x1955	4
46	reinforcing plate		4
47	weight stack		2
48	hexagon bolt	M10x20	8
90	selector rod		2
91	weight pin		2

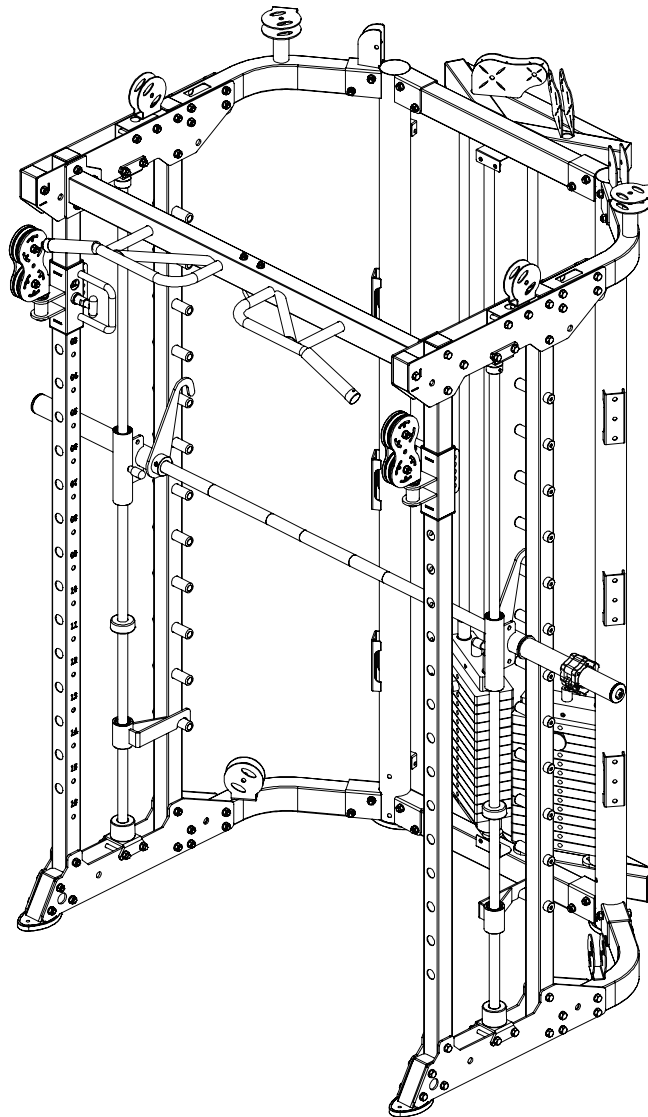

- 1 Fix weight pin-91 fastening on selector rod-90
- 2 Guide rod hollow-45 in turn through rubber pad-44, weight stack-47 and fastening on reinforcing plate-46 using M10x20 hexagon bolt-48, $\Phi 10$ washer-11 and M10 lock nut-10

Assembly step 5

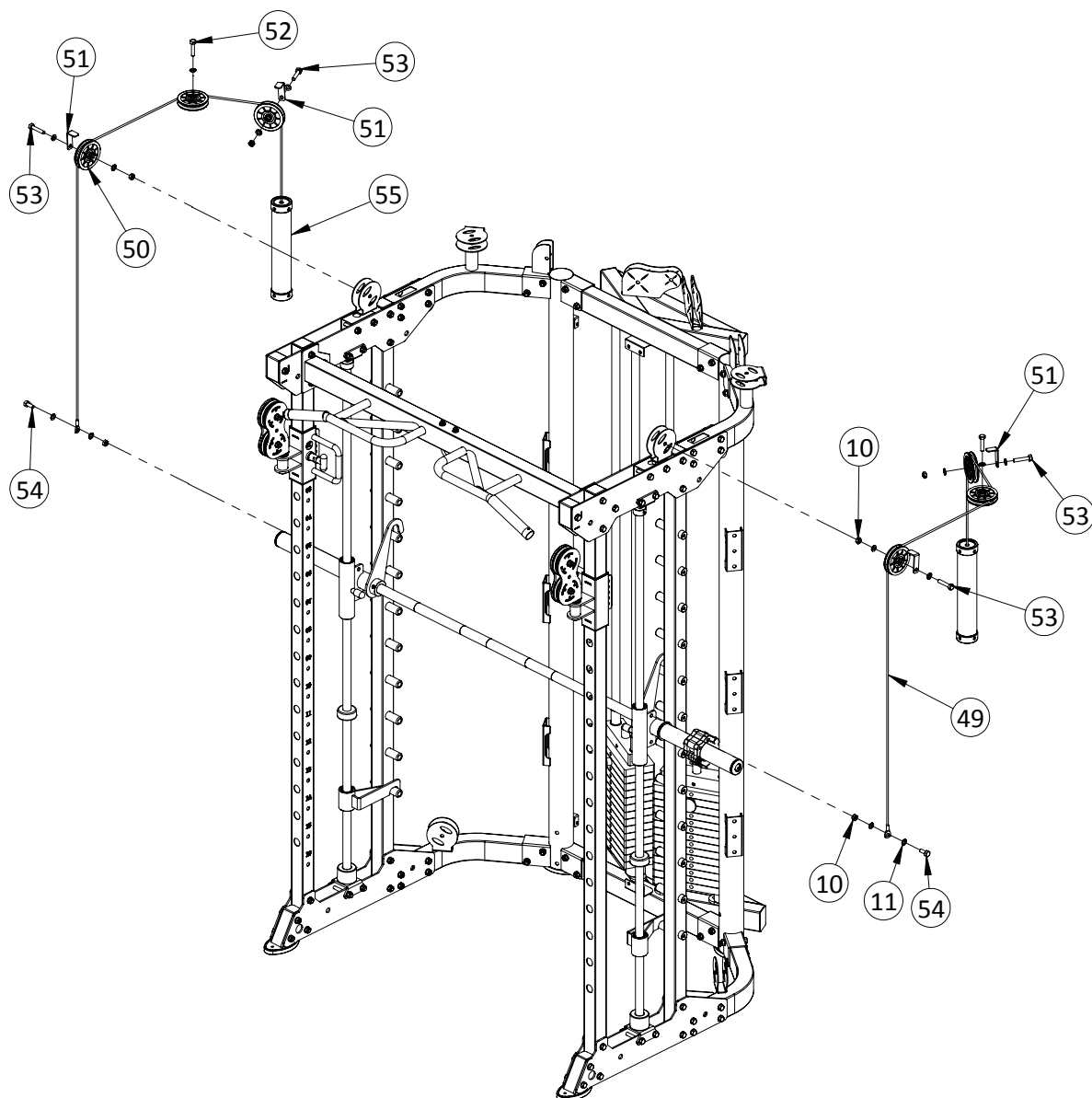

No.	Description	Note	Qty.
10	lock nut	M10	6
11	washer	Φ10	14
49	wire	Φ5x2745mm	2
50	pulley	Φ95	6
51	pulley plate		4
52	hexagon bolt	M10x45	2
53	hexagon bolt	M10x50	4
54	hexagon bolt	M10x25	2
55	weight		2

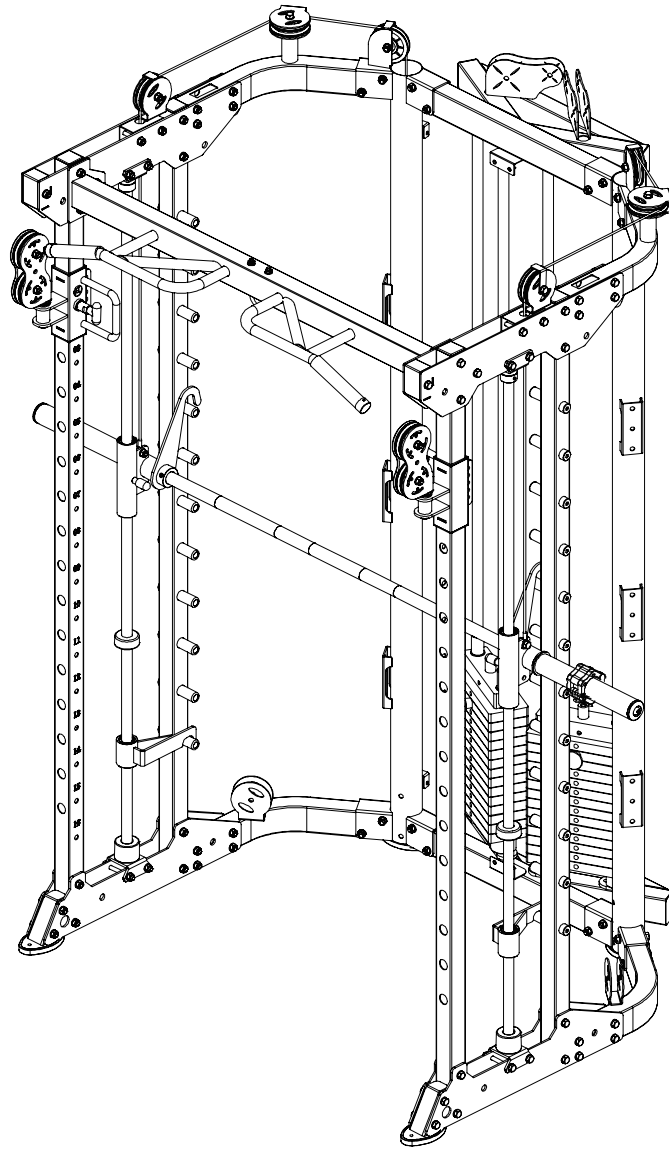

- 1 Connect wire-49 with weight-55, put them into spring frame
- 2 Fix pulley-50 fastening on upper bending tube using M10x50 hexagon bolt-53, pulley plate-51, $\Phi 10$ washer-11 and M10 lock nut-10
- 3 Fix pulley-50 fastening on upper bending tube using M10x45 hexagon bolt-52, $\Phi 10$ washer-11 and M10 lock nut-10
- 4 Fix wire-49 fastening on sliding sleeve outside using M10x25 hexagon bolt-54, $\Phi 10$ washer-11 and M10 lock nut-10

Assembly step 6

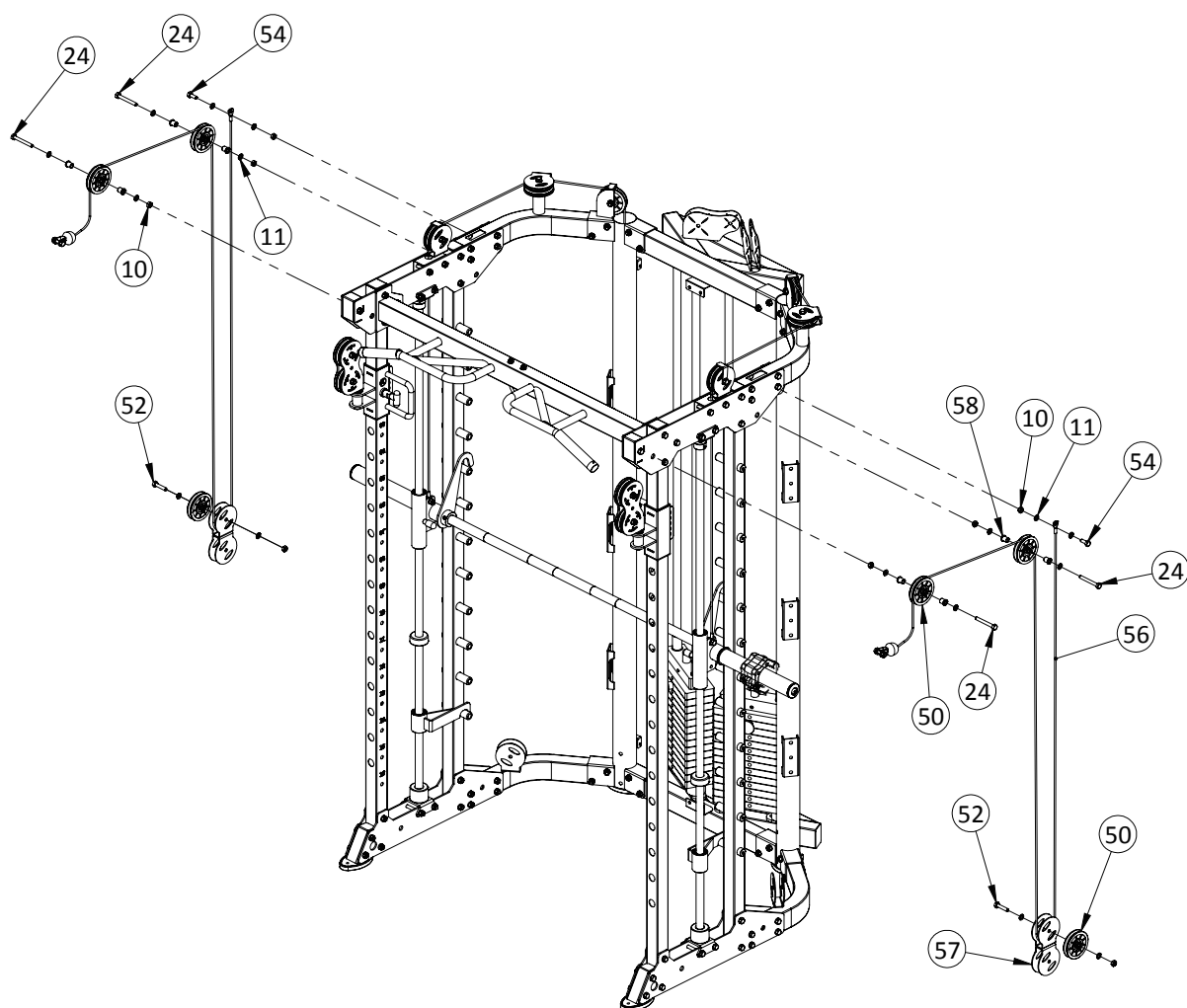

No.	Description	Note	Qty.
10	lock nut	M10	8
11	washer	Φ10	16
24	hexagon bolt	M10x80	4
50	pulley	Φ95	6
52	hexagon bolt	M10x45	2
54	hexagon bolt	M10x25	2
56	wire	Φ5x4095mm	2
57	"-" shaped pulley frame		2
58	pulley spacer sleeve	Φ20x10.5xL20.5	8

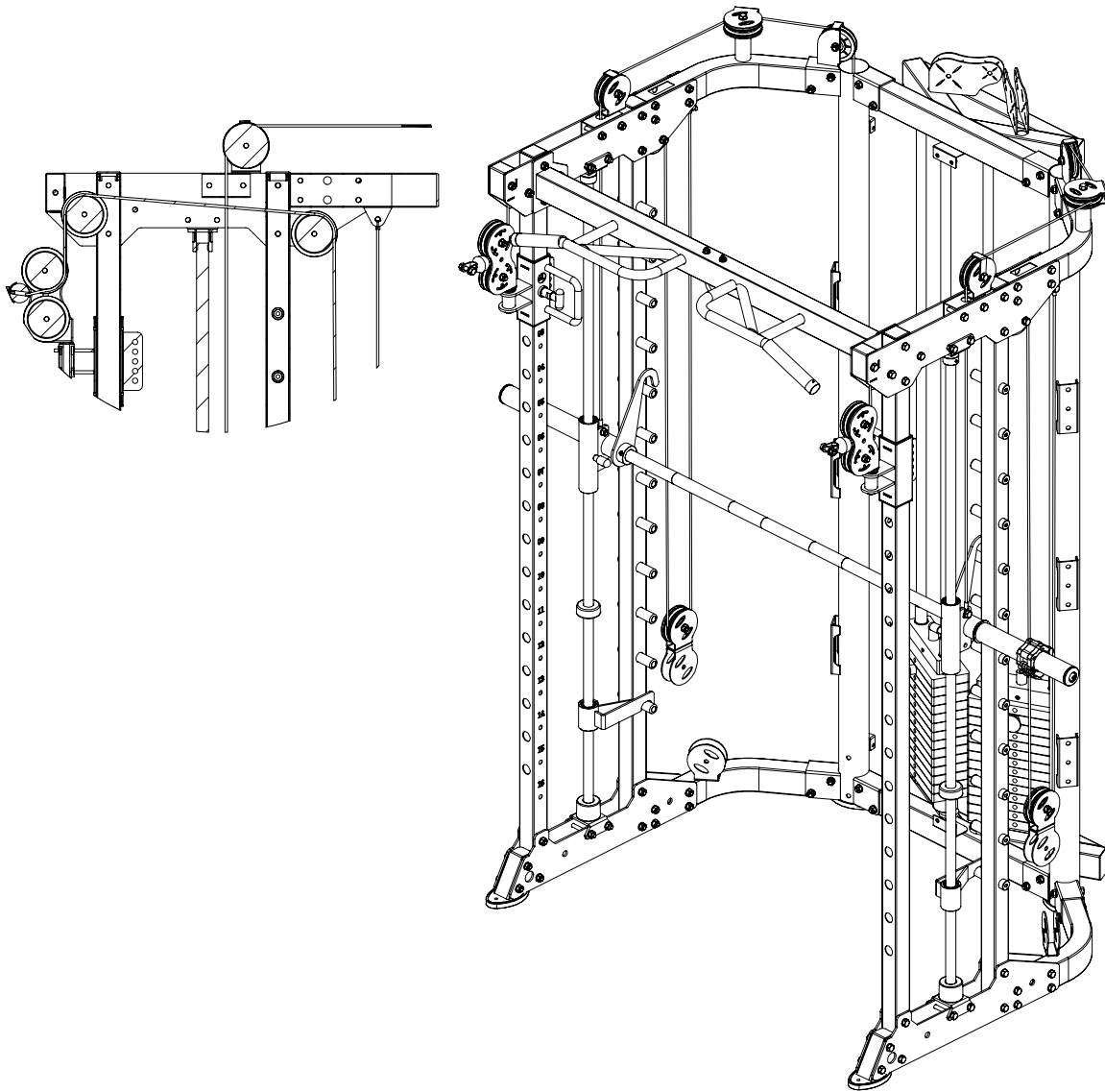

- 1 As the shown in the figure fix pulley-50 fastening on upper plate using M10x80 hexagon bolt-24, $\Phi 10$ washer-11 and M10 lock nut-10 and pulley spacer sleeve-58
- 2 Fix pulley-50 fastening on "—" shape pulley frame-57 using M10x45 hexagon bolt-52, $\Phi 10$ washer-11 and M10 lock nut-10
- 3 As the shown in the figure put the wire-56 using M10x45 hexagon bolt-52, $\Phi 10$ washer-11 and M10 lock nut-10 fastening on bending tube, careful to keep the wire vertical

Assembly step 7

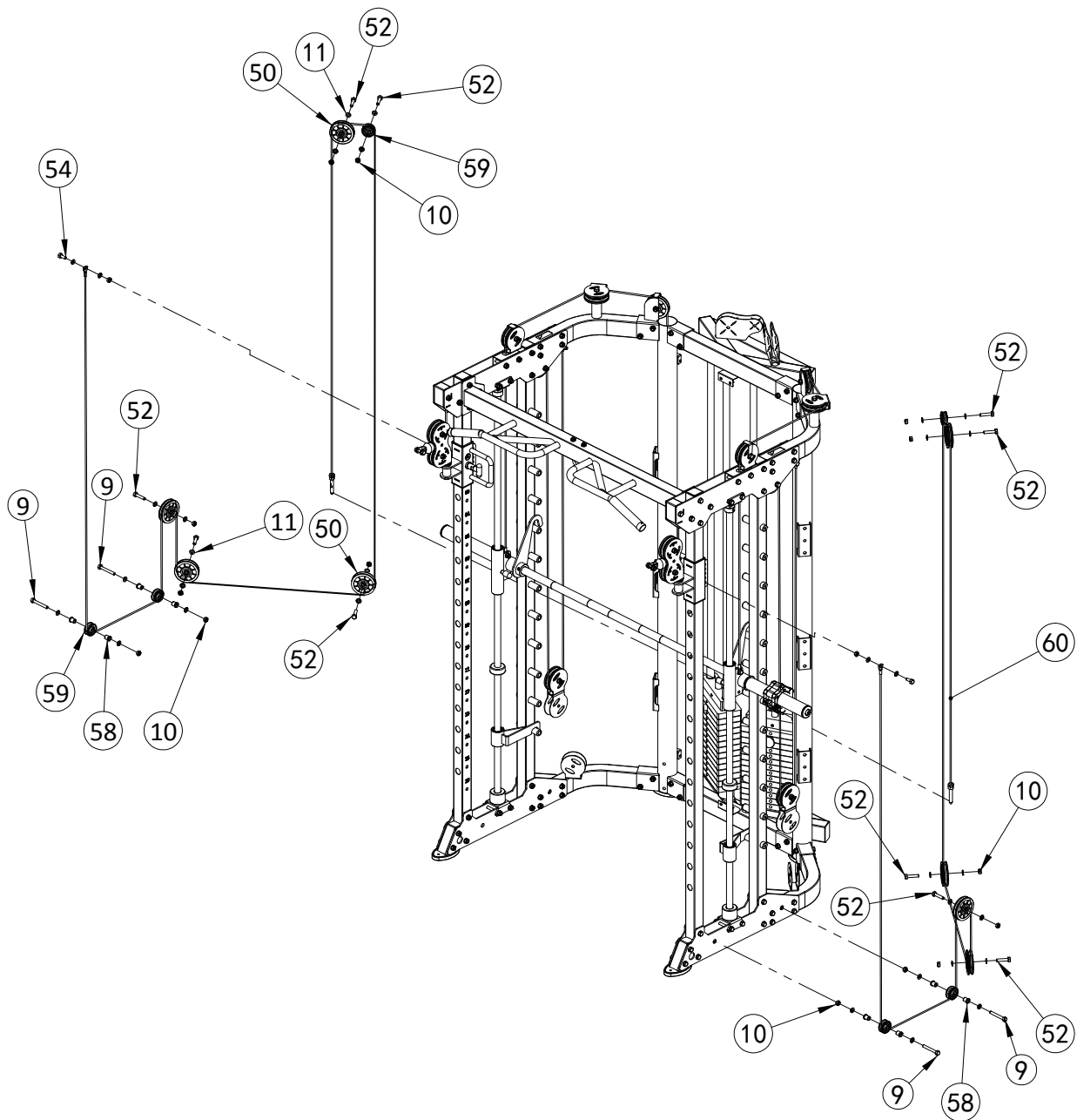

No.	Description	Note	Qty.
24	hexagon bolt	M10x80	4
10	lock nut	M10	16
11	washer	Φ10	32
50	pulley	Φ95	8
52	hexagon bolt	M10x45	10
54	hexagon bolt	M10x25	2
58	pulley spacer sleeve	Φ20x10.5xL20.5	8
59	pulley	Φ50	6
60	wire		2

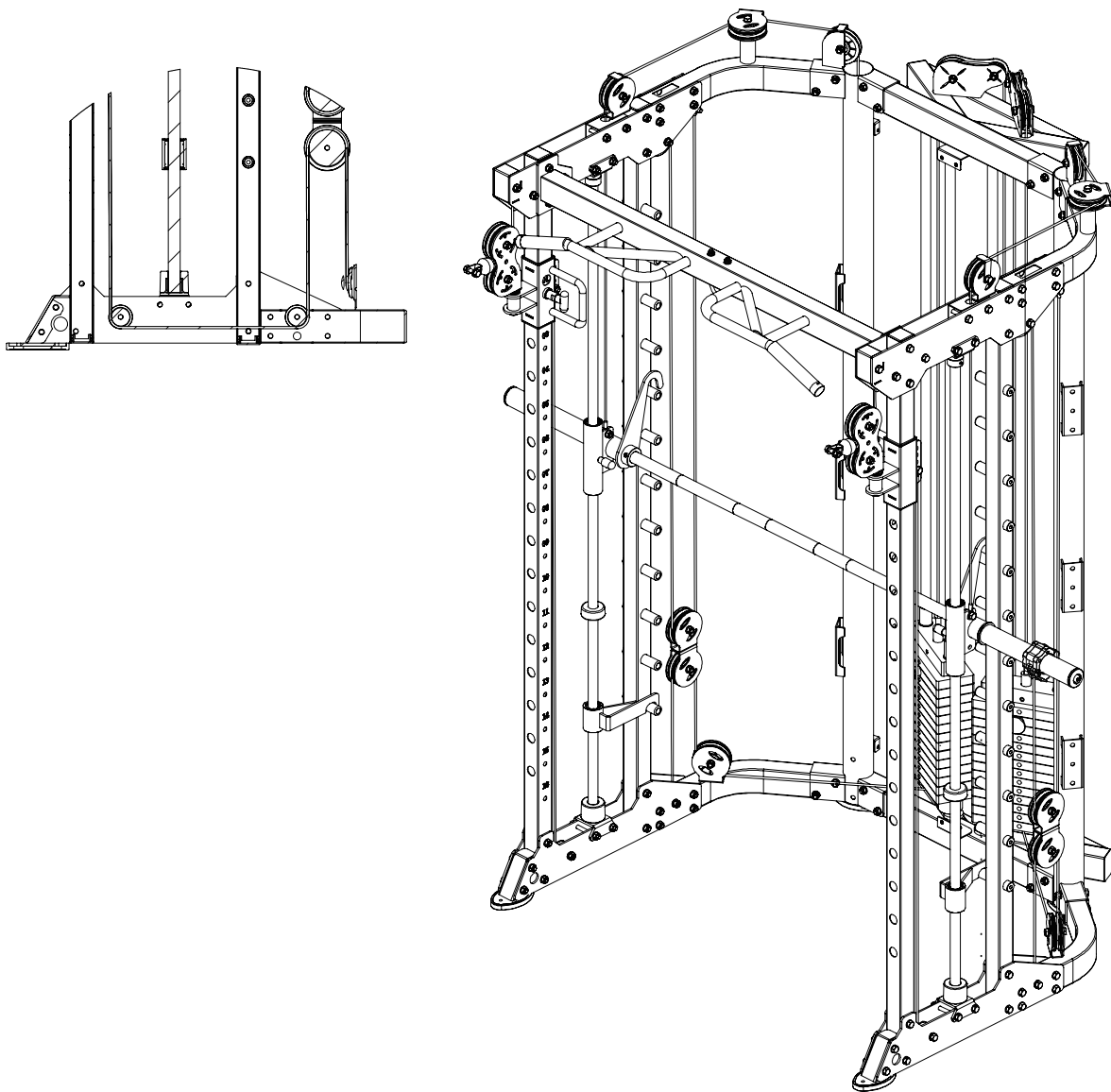

- 1 Fix pulley-50 fastening on "—" shape pulley frame-57 using M10x45 hexagon bolt-52, Φ 10 washer-11 and M10 lock nut-10
- 2 Fix pulley-50 fastening on lower plate using M10x80 hexagon bolt-24, Φ 10 washer-11 and M10 lock nut-10 and pulley spacer sleeve-58
- 3 Fix pulley-50 fastening on lower bending tube using M10x45 hexagon bolt-52, Φ 10 washer-11 and M10 lock nut-10
- 4 As the shown in the figure put the wire-60 on the machine

Assembly step 8

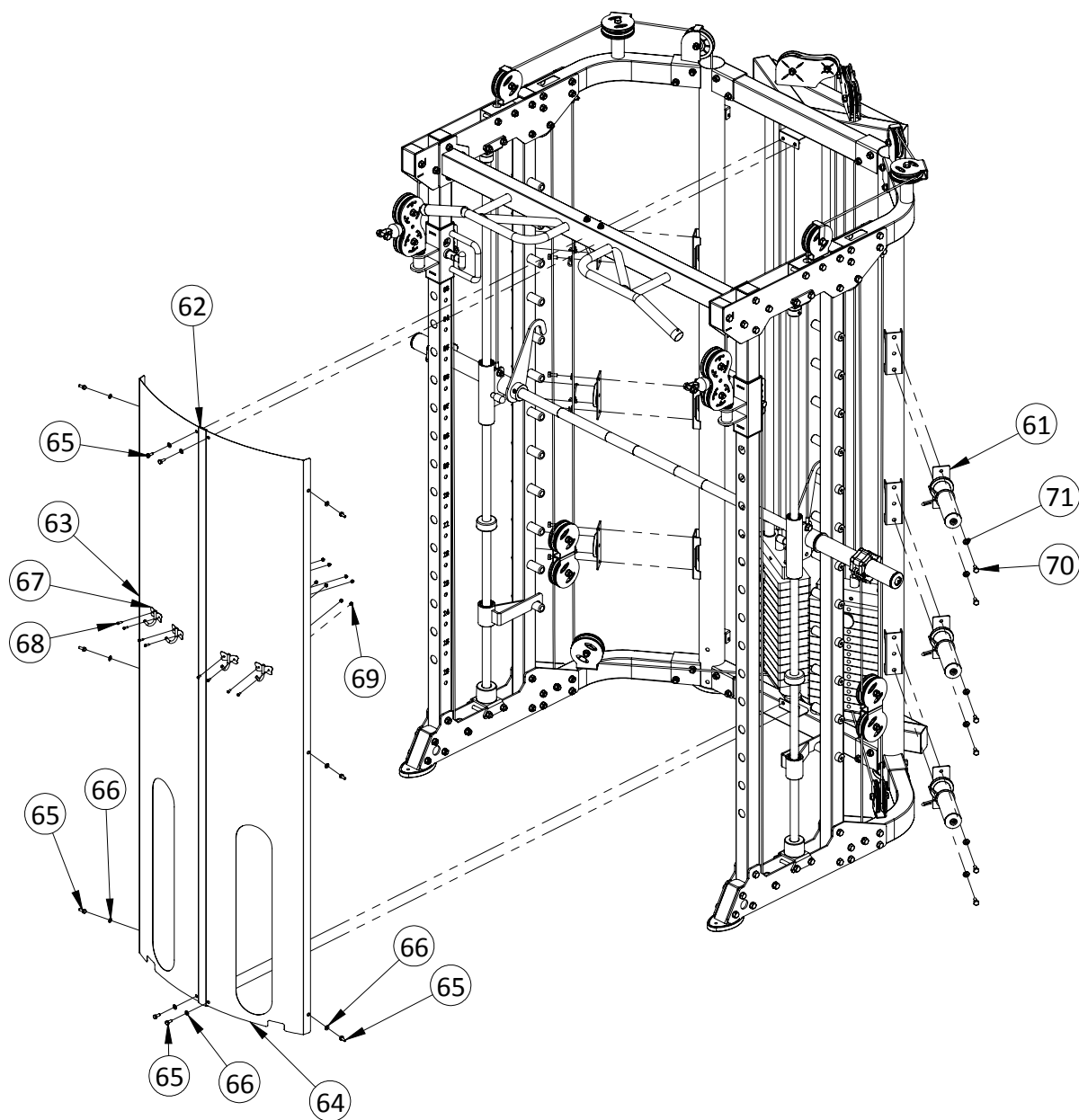

No.	Description	Note	Qty.
61	barbell plate holder		6
62	connection strap		1
63	shield left		1
64	shield right		1
65	hexagon bolt	M6x16	10
66	washer	Φ6	10
67	hook		4
68	"+"slotted countersunk head bolt	M4x12	8
69	lock nut	M4	8
70	hexagon bolt	M8x20	12
71	washer	Φ8	12

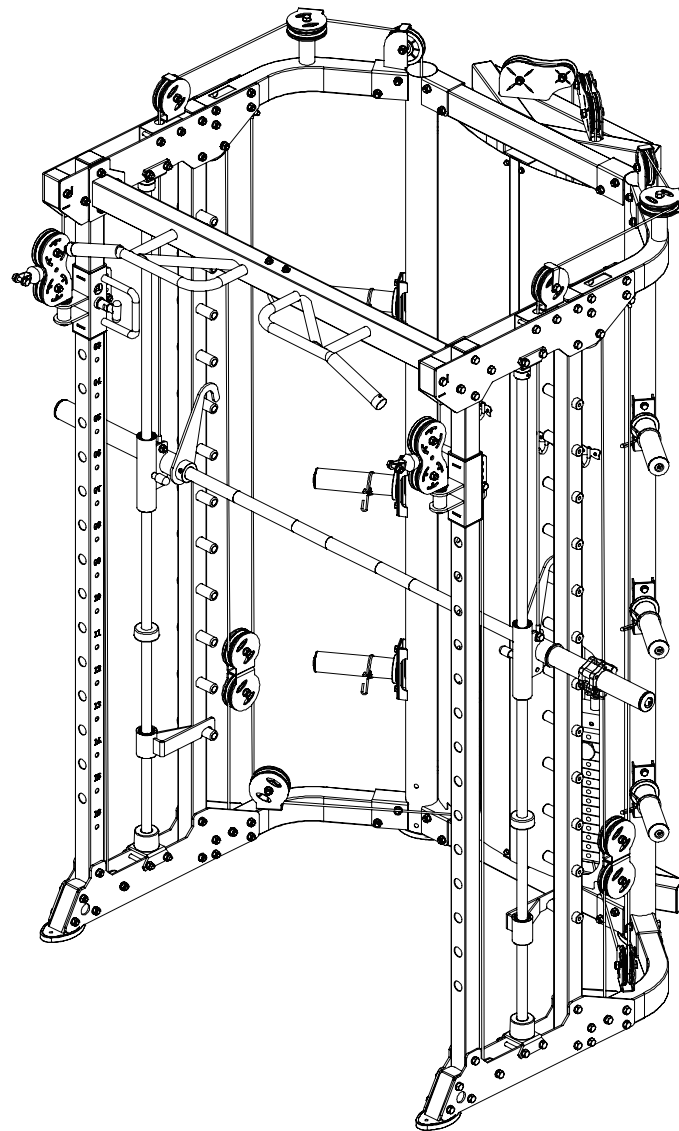

- 1 Connect shield left-63, connection strap-62 and shield right-64
- 2 Fix hook-67 fastening on shield using "+"slotted countersunk head bolt-68 and M4 lock nut-69
- 3 Fix shield fastening on main frame using M6x16 hexagon bolt-65, $\Phi 6$ washer-66
- 4 Fix barbell plate holder-61 on main frame using M8x20 hexagon bolt-70, $\Phi 8$ washer-71

Assembly step 9

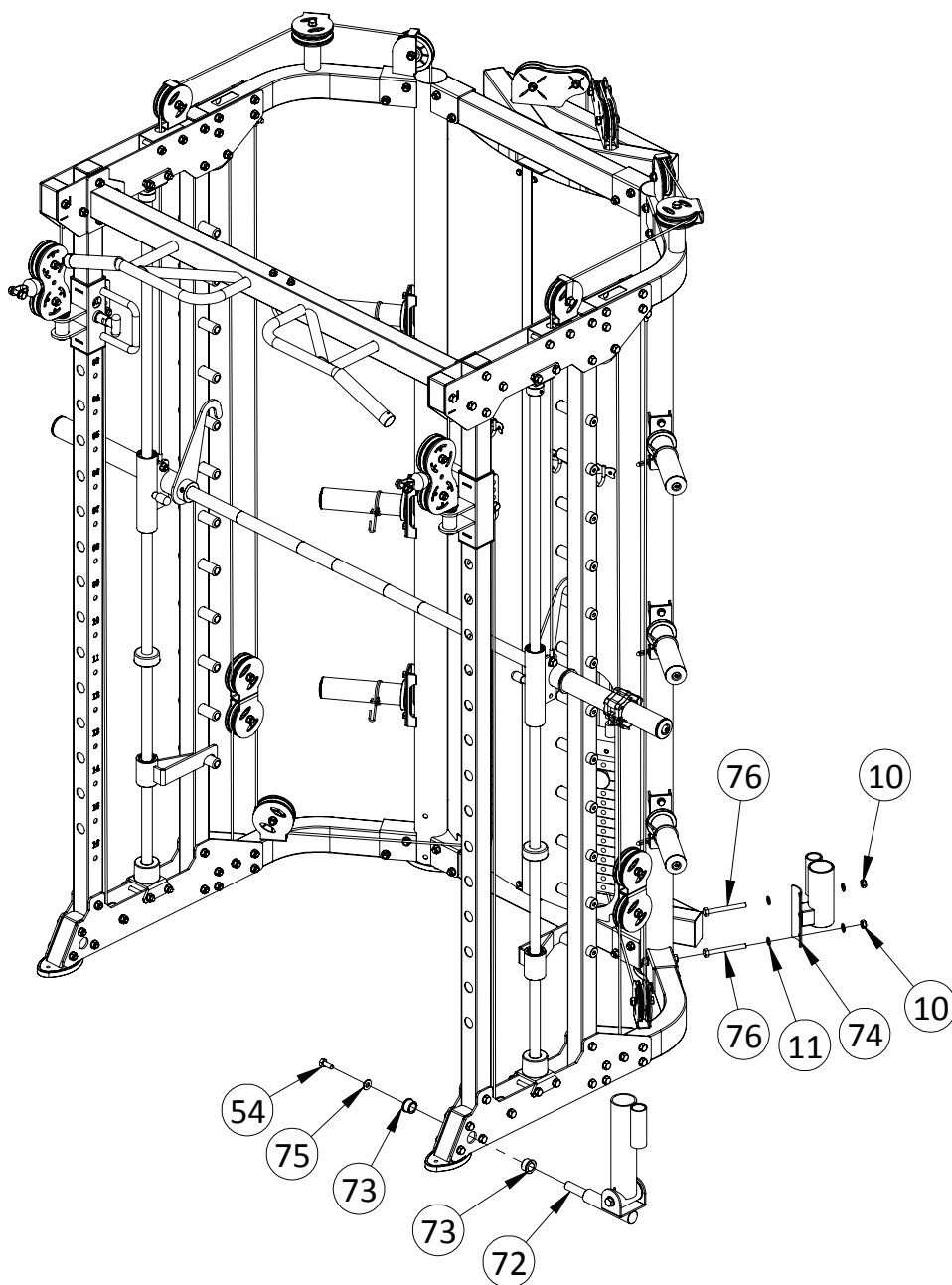

No.	Description	Note	Qty.
10	lock nut	M10	2
11	washer	Φ10	4
54	hexagon bolt	M10x25	1
72	core trainer		1
73	powder metallurgy sleeve		2
74	barbell rod cup		1
75	big washer	Φ25x10x2.0	1
76	hexagon bolt	M10x95	2

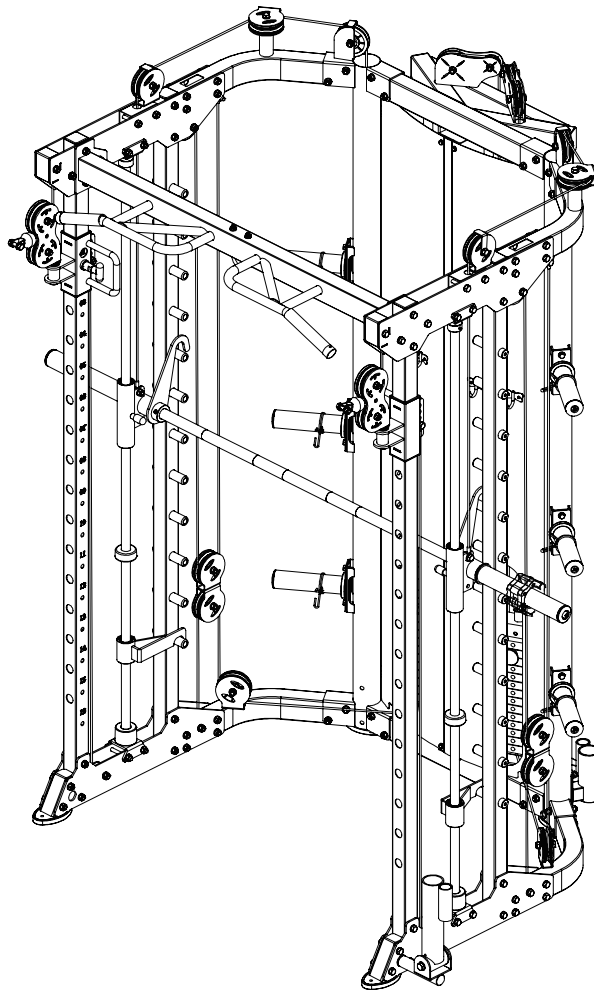

- 1 Fix core trainer-72 fastening on main frame using M10x25 hexagon bolt-54, Φ 10 big washer-75 and powder metallurgy sleeve-73
- 2 Fix barbell rod cup-74 fastening on upright frame using M10x95 hexagon bolt-76, Φ 10 washer-11 and M10 lock nut-10

Assembly step 10

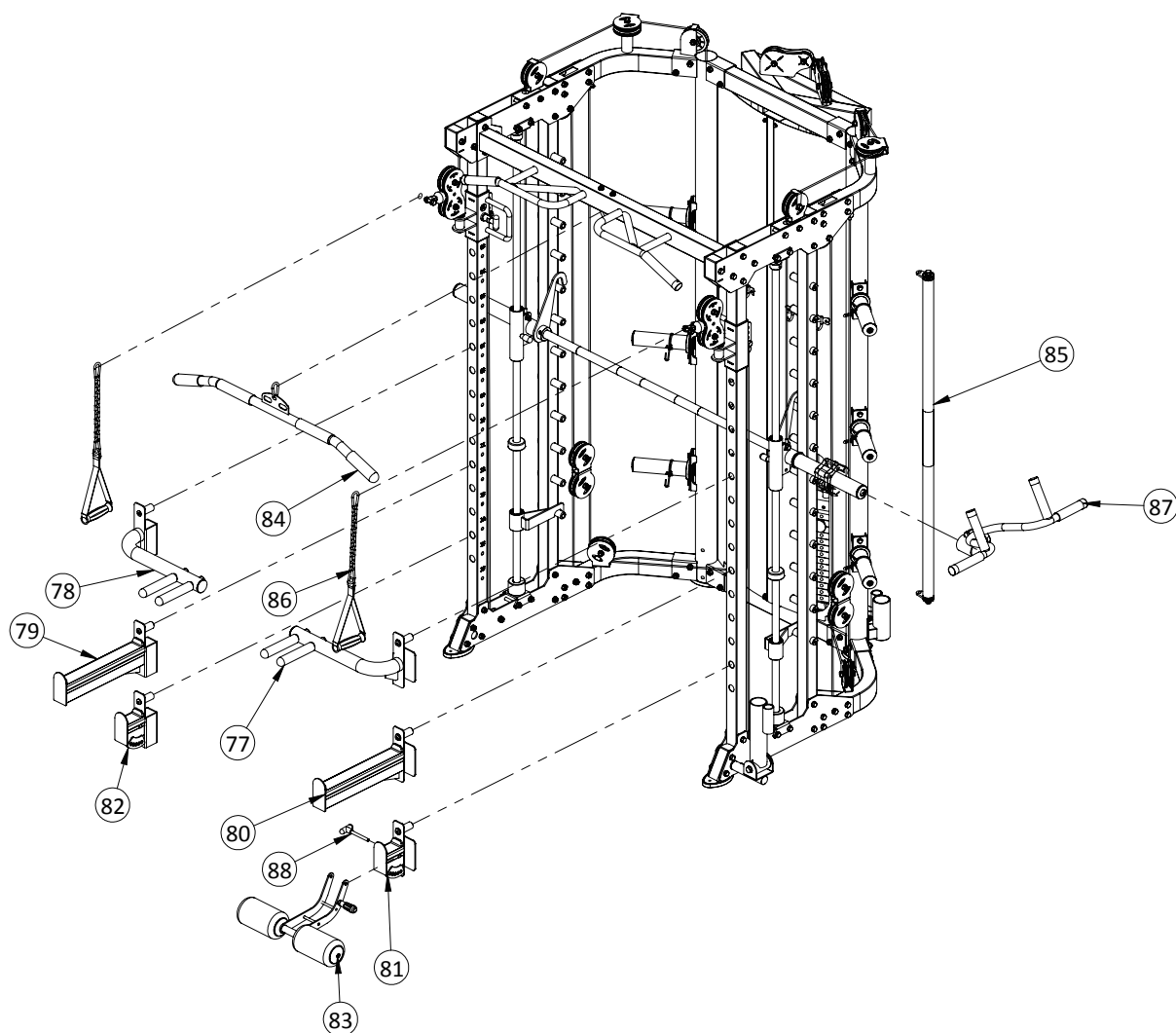

No.	Description	Note	Qty.
77	dip bar left		1
78	dip bar right		1
79	barbell rod holder right		1
80	barbell rod holder left		1
81	barbell rod holder short left		1
82	barbell rod holder short right		1
83	long bar		1
84	ship rod		1
85	hand belt		2
86	pull lift device		1
87	T shape pin	Φ10x100	1
88	leg curl tube		1

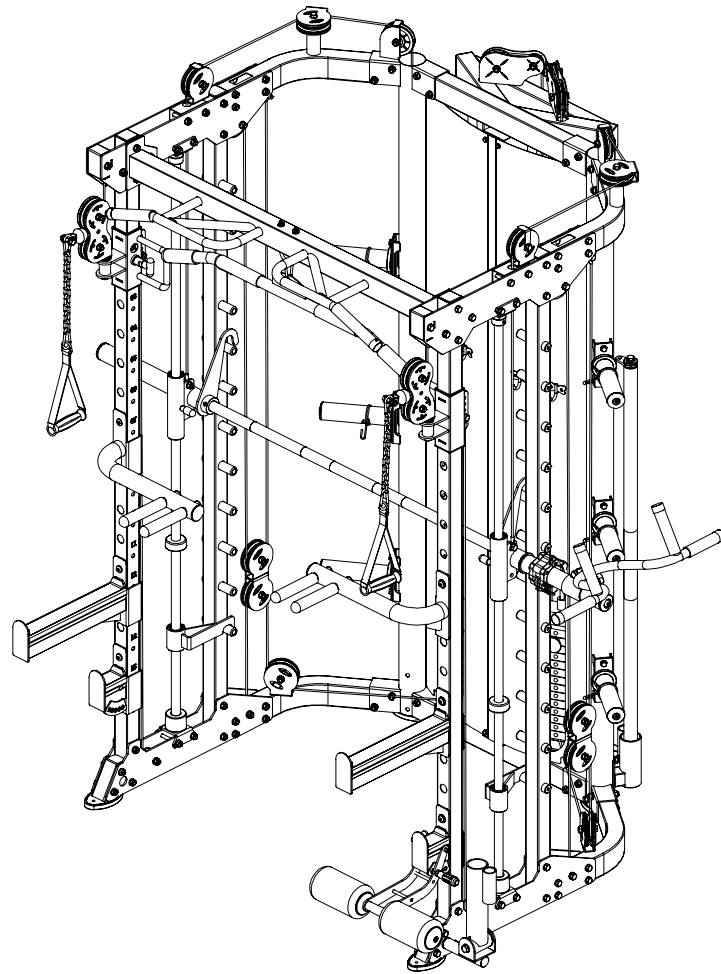

- 1 Connect leg curl tube-83 and barbell rod holder short left-81 using T shape pin-88
- 2 Put the attached part on the machine

Assembly step 11

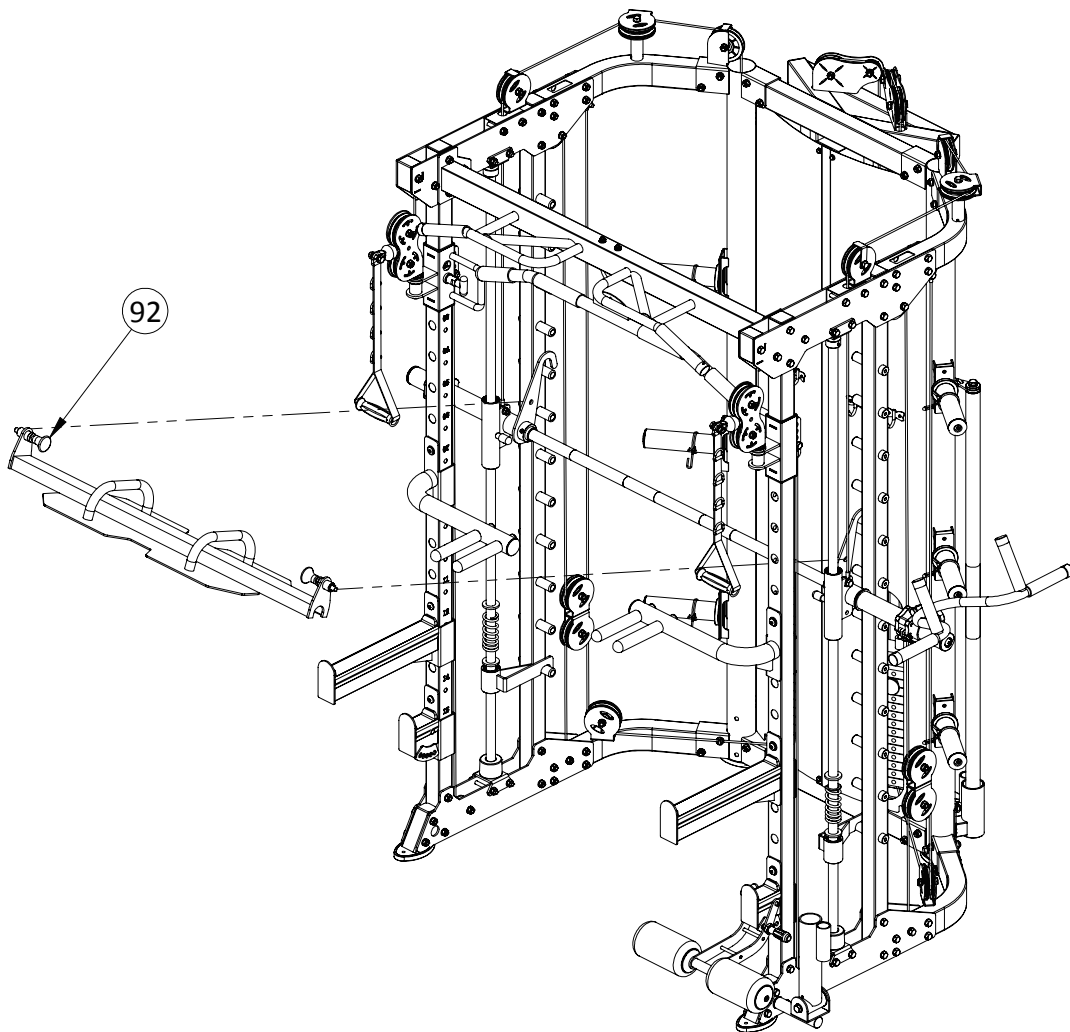

No.	Description	Note	Qty.
92	footplate		1

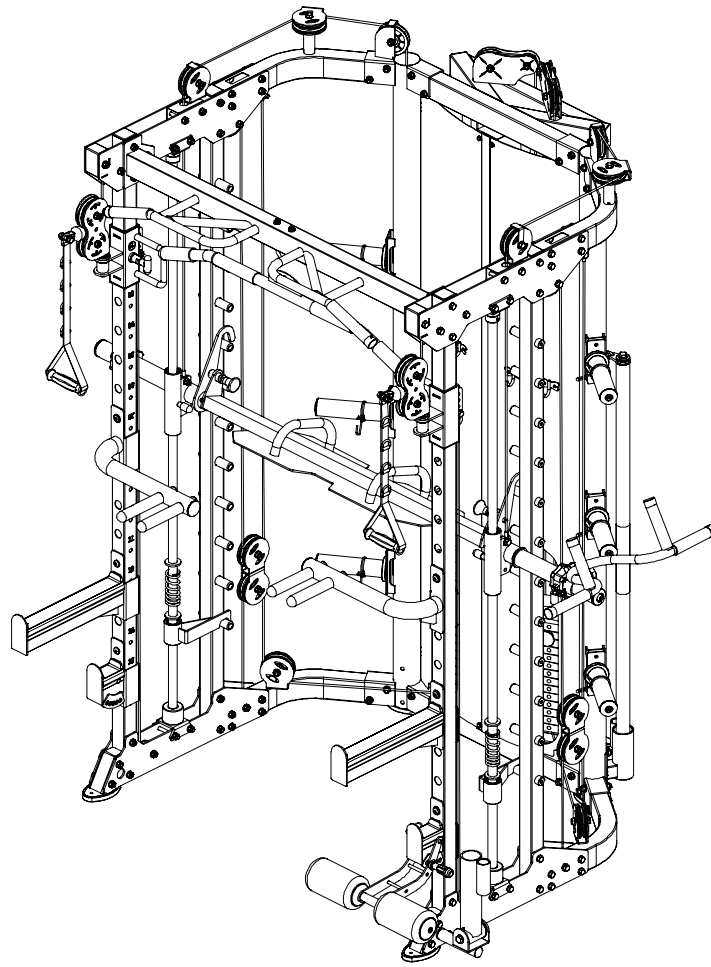

Put the footplate-92 on the machine